

Ultrasound System

Cleaning, Disinfection & Sterilization Guide

[Advanced]



Ultrasound system
Cleaning, Disinfection & Sterilization Guide
[Advanced]



Thank you for purchasing Mindray's products. To ensure safe and correct operation, carefully read and understand this guide. Keep this guide carefully after reading, so that you can check it whenever necessary. For the latest Ultrasound cleaning, disinfection, and sterilization guide, please visit <https://www.mindray.com/en/resources-center/mis-guide-manual> or scan the above QR code.

Intellectual Property Statement

SHENZHEN MINDRAY BIO-MEDICAL ELECTRONICS CO., LTD. (hereinafter called Mindray) owns the intellectual property rights to this Mindray product and this manual. This manual may refer to information protected by copyright or patents and does not convey any license under the patent rights or copyright of Mindray, or of others.

Mindray intends to maintain the contents of this manual as confidential information. Disclosure of the information in this manual in any manner whatsoever without the written permission of Mindray is strictly forbidden.

Release, amendment, reproduction, distribution, rental, adaptation, translation or any other derivative work of this manual in any manner whatsoever without the written permission of Mindray is strictly forbidden.

mindray,  and **MINDRAY** are the trademarks, registered or otherwise, of Mindray in China and other countries. All other trademarks that appear in this manual are used only for informational or editorial purposes. They are the property of their respective owners.

This posting serves as notice under 35 U.S.C.§287(a) for Mindray patents: <http://www.mindrayna.com/patents>.

Statement

Contents of this document are subject to changes without prior notice.

Mindray is responsible for the effects on safety, reliability and performance of this product, only if:

- All installation operations, expansions, changes, modifications and repairs of this product are conducted by Mindray authorized personnel;
- The electrical installation of the relevant room complies with the applicable national and local requirements and requirements of this guide;
- The product is used in accordance with the instructions for use.

Table of Contents

	Intellectual Property Statement.....	ii
	Statement	ii
	Customer Service Department	1
	Important Information	1
	About this Guide.....	2
	Meaning of Signal Words.....	2
1	General Information About Cleaning, Disinfection and Sterilization.....	3
	1.1 Safety Precautions	3
	1.2 Brief Introduction to Materials	4
	1.2.1 Plastics	4
	1.2.2 Stainless Steel.....	5
	1.2.3 Silica Gel	5
	1.2.4 Epoxy Glue	5
	1.2.5 Glass	5
2	Inspection Before and After Use	7
	2.1 Appearance Inspection	7
	2.2 Use of Probe Sheath.....	7
	2.3 Wearing the Probe Sheath.....	8
3	Cleaning, Disinfecting/Sterilizing Probes	9
	3.1 Cleaning, Disinfection, and Sterilization Overview.....	10
	3.2 Selecting a Cleaning, Disinfection/Sterilization Method.....	10
	3.3 Processing Non-Critical Probes	11
	3.4 Processing Semi-Critical Probes.....	12
	3.4.1 Before Processing	12
	3.4.2 Cleaning	12
	3.4.3 High-Level Disinfection.....	13
	3.5 Processing Critical Probes	14
	3.5.1 Before Processing	15
	3.5.2 Cleaning	15
	3.5.3 Sterilization	16

4	Cleaning and Disinfecting the TEE Probe	19
4.1	Before Processing.....	20
4.2	Cleaning.....	20
4.3	Disinfection.....	21
4.3.1	Disinfection using Disinfectant.....	21
4.3.2	Disinfection using Disinfection System.....	22
4.4	Validated Cleaner and Disinfectant/Disinfection System	22
4.4.1	Cleaner	22
4.4.2	Disinfectant.....	23
4.4.3	Disinfection System	25
4.5	Recommended Automated Reprocessor (AR).....	25
5	Cleaning and Sterilizing the Laparoscopic Probe	27
5.1	Before Processing.....	27
5.2	Cleaning.....	28
5.3	Sterilization.....	29
5.3.1	Sterilization using Sterilization System.....	29
5.3.2	Sterilization using Solution	30
5.4	List of Cleaner, Disinfectant and Sterilant/Sterilization System.....	31
5.4.1	Validated Cleaner and Sterilant/Sterilization System	31
5.4.2	Material Compatible Disinfectant.....	32
6	Cleaning and Sterilizing the Needle-guided Bracket	35
6.1	Cleaning.....	35
6.2	Sterilization.....	36
6.2.1	Sterilization with a Sterilant	36
6.2.2	High-Pressure Steam Sterilization.....	36
7	Cleaning and Disinfecting the Main Unit	39
7.1	Cleaning.....	39
7.1.1	Cleaning the Display.....	39
7.1.2	Cleaning the Control Panel.....	40
7.1.3	Cleaning the Cover	40
7.1.4	Cleaning Other Parts	40
7.2	Disinfection.....	41
7.2.1	Identifying the Areas That can be Disinfected	42
7.2.2	Disinfection Procedure	60
7.2.3	Compatible Disinfectants.....	60
8	Cleaning Other Accessories	65
8.1	Cleaning the Holders.....	65

8.2	Cleaning the ECG Cables	65
8.3	Cleaning the Peripherals.....	65
Appendix A Compatible Probe Cleaners and Disinfectants		67
A.1	Cleaners.....	67
A.2	Disinfectants.....	71
A.2.1	Wipes.....	71
A.2.2	Sprays	77
A.2.3	Solutions.....	80
A.2.4	Devices.....	83
A.2.5	Powders.....	85
Appendix B Composition		87
B.1	Active Ingredients of the Cleaner	87
B.2	Active Ingredients of the Disinfectant.....	87
Appendix C Registered Disinfectants in Canada.....		91
Appendix D Registered Disinfectants in FDA Region		93

This page intentionally left blank.

Customer Service Department

Manufacturer:	Shenzhen Mindray Bio-Medical Electronics Co., Ltd.
Address:	Mindray Building, Keji 12th Road South, High-Tech Industrial Park, Nanshan, Shenzhen, 518057, P. R. China
Website:	www.mindray.com
E-mail Address:	service@mindray.com
Tel:	+86 755 81888998
Fax:	+86 755 26582680

EC-Representative:	Shanghai International Holding Corp. GmbH(Europe)
Address:	Eiffestraße 80, 20537 Hamburg, Germany
Tel:	0049-40-2513175
Fax:	0049-40-255726

Manufacturer:	Mindray DS USA, Inc.
Address:	800 MacArthur Blvd. Mahwah, NJ 07430-0619 USA
Tel:	+1 (201) 995-8000
Toll Free:	+1 (800) 288-2121
Fax:	+1 (800) 926-4275

Important Information

Thank you for your expression of confidence in the Mindray brand name. Mindray is constantly working on the further development of all products. Please appreciate that changes to the scope of supply in form, equipment and technology are possible for this reason. Therefore, no claims may be deduced from the information, figures and descriptions in this guide.

This guide contains warnings regarding foreseeable potential dangers, but you shall always be alert to dangers other than those indicated as well. Mindray shall not be liable for damage or loss that results from negligence or from ignoring the precautions and operating instructions described in this guide.

If the administrator for this system is changed, be sure to hand over this guide to the new manager.

WARNING

The probe and accessories supplied with it are not delivered disinfected or sterilized. Cleaning and disinfection (or sterilization) in accordance with this guide before use are required. After disinfection or sterilization, residual chemicals must be completely removed. Otherwise, personal injury or damage to the probes or accessories may occur.

About this Guide



Please follow the descriptions in the guide to clean and disinfect (or sterilize) the probes, needle-guided brackets, entire machine and accessories manufactured by Mindray. The guide is intended to provide information about cleaning and disinfecting (or sterilizing) the ultrasound system effectively, and also about protecting the ultrasound system from damages caused by incorrect cleaning, disinfection or sterilization procedures.



Mindray has verified that the disinfectants and disinfection equipment described in this guide are compatible with the ultrasound system. All the verified disinfectants are listed in disinfectant list of this guide.

The disinfectants and sterilants described in the guide are recommended by Mindray. For details on effectiveness and clinical application of these disinfectants and sterilants, refer to the instructions of disinfectant and sterilant manufacturers.

The functions and accessories described in the guide may vary with the specific system you purchased.

Meaning of Signal Words

In this guide, the signal words  **DANGER**,  **WARNING**,  **CAUTION**, **NOTE** and Tip are used regarding safety and other important instructions. The signal words and their meanings are defined as follows. Please understand their meanings clearly before reading this guide.

Signal word	Meaning
 WARNING	Indicates a potentially hazardous situation that, if not avoided, could result in death or serious injury.
 CAUTION	Indicates a potentially hazardous situation that, if not avoided, may result in minor or moderate injury.
NOTE	Indicates a potentially hazardous situation that, if not avoided, may result in property damage.

1 General Information About Cleaning, Disinfection and Sterilization

1.1 Safety Precautions

Follow the following precautions strictly to ensure the safety of the patient and the operator.

WARNING

- Do not subject the probe to shock. A defective probe may cause electric shock to the patient.
- Do not disassemble the probe to avoid the possibility of electric shock.
- Never immerse the probe connector into liquids such as water or disinfectant, for the connector is not waterproof. Immersion may cause electric shock or malfunction.
- In normal diagnostic ultrasound mode, there is no danger of a normal-temperature burn; however, keeping the probe on the same region of the patient for a long time may cause such a burn.

CAUTION

- The probe is only for use with the specified ultrasonic diagnostic system. Please refer to the ultrasonic diagnostic system operation manual to select the proper probe.
- For clinical applications of a semi-critical or critical nature (e.g., intraoperative, transrectal, transvaginal, transesophageal, or biopsy procedures), it is recommended, when appropriate, to use sterile, legally marketed probe sheaths.
- Damage to the probe may occur due to its contact with improper detergents or coupling gel. DO NOT dip the probe in the strong polar solution of ethanol, chloride of lime, ammonium chloride, acetone and formaldehyde. The probe should not make contact with solution or ultrasound gel containing oily medium such as mineral oil or lanoline.
- Coupling gel must be used during ultrasonic examination. Please use the ultrasound gel compliant with the relevant local regulations. And manage the ultrasound gel properly to ensure that it does not become a source of infection.
- Do not use the carrying case for storing the probe. If the carrying case is used for storage, it may become a source of infection.

- **The probe and accessories supplied with it are not delivered disinfected or sterilized. Cleaning and disinfection (or sterilization) in accordance with this guide before use are required.**
- **Disposable components are packaged sterile and can be used once only. Do not use if integrity of packaging violated or if expiration date has passed. Please use the disposable components compliant with the relevant local regulations.**
- **Use the disinfection or sterilization solution recommended in this guide only. Otherwise, Mindray will not be liable for damage caused by other solutions. If you have any questions, please contact Mindray Customer Service Department.**

NOTE:

- Read the following precautions to prevent the probe from malfunction:
- Before connecting or disconnecting the probe, freeze the ultrasonic image or turn off the diagnostic ultrasound system.
- After completing each examination, clean, disinfect or sterilize the probes as required. If necessary, repeat the cleaning, disinfection (or sterilization) process before next use.
- To prevent the probe from being damaged, do not use it where it will be exposed to:
 - Locations exposed to direct sunlight
 - Locations subject to sudden changes in environmental temperature
 - Dust
 - Excessive vibration
 - Locations near heat generators
- Cleaning cannot be replaced by sterilization. Probes and needle-guided brackets must be cleaned before sterilization.
- Repeated disinfection will eventually damage the probe, please check the probe performance periodically.
- Repeated disinfection will degrade the performance and safety of the needle-guided brackets.

1.2 Brief Introduction to Materials

1.2.1 Plastics

Plastic is material consisting of any of a wide range of synthetic or semi-synthetic organic compounds that are malleable and so can be molded into solid objects. It is made up of additives including synthetic resin, filler, plasticizer, stabilizer and pigment.

The plastic housing molded by injection molding process is anti-stamping, heat-resistant and stable in dimensions. However, some general engineering plastics (especially ABS) contain unsaturated double bonds. During the storage or application of these plastics, due to external factors such as illumination and oxidization, unsaturated double bonds will result in yellowing, degraded mechanical performance or even cracking.

Plastics in reusable medical devices manufactured by Mindray can be cleaned and disinfected (or sterilized) by using the recommended methods. For all plastics cannot withstand repeated actions of alcohols, do not disinfect or sterilize the plastic material in a way that is not recommended.

Plastic is mainly used in probe housings.

1.2.2 Stainless Steel

Stainless steel is corrosion resistant due to a natural passive layer which forms in the air. If this passive layer is destroyed by certain substances (solid, liquid or gaseous), there is no longer any corrosion resistance. The stainless steels may also corrode, particularly if they are in contact with blood or tissue residues.

Therefore make certain, not only for hygienic reasons, that organic remnants have been completely removed.

Stainless steel is mainly used in needle-guided brackets.

1.2.3 Silica Gel

Silica gel is excellent in thermo oxidative stability, weather resistance, and resistance to oxygen, ozone and ultraviolet radiation, for the backbone of silica gel consists of Si-O-Si bonds. However, polysiloxane has a helical structure and therefore has a good gas and vapor permeability.

The long-time immersion disinfection or sterilization may result in the inflation of polysiloxane. And the solution may permeate silica gel to damage the parts protected by silica gel. Therefore, disinfection should be performed in accordance with the immersion time specified by the disinfectant manufacturer.

Nevertheless, silica gel attracts dirt. Thus, make sure that organic residues are removed completely after cleaning and disinfection (or sterilization).

Silica gel is mainly used in sealant of acoustic lens and housing of probe.

1.2.4 Epoxy Glue

Epoxy glue, as one kind of thermosetting resins, has a good bonding effect on various interfaces, even in a high temperature of 110°C. It has resistance to ultraviolet radiation, erosion and weather.

The long-term immersion in peroxymonosulfuric acid, hydrogen peroxide, hypochlorite or glutaraldehyde may discolor epoxy glue slightly, but will not affect its performance.

Epoxy glue is mainly used in sealing of the probe housing.

1.2.5 Glass

Glass is mainly made up of various inorganic mineral substances, such as Zircon sand, borax and sodium carbonate. It also contains a little auxiliary materials. Its main ingredients are SiO₂ and other oxide. It has resistance to erosion.

Long-time immersion in disinfectant or sterilant solution will not affect its chemical properties.

Glass is mainly used in monitor and touch screen of the ultrasound system.

This page intentionally left blank.

2 Inspection Before and After Use

Brand new equipment should be unpacked and checked after delivery. If there is any transport damage, contact Mindray Customer Service Department immediately.

Every probe passes through an extensive cleaning and final check at the end of the manufacturing process. However, soiling is possible during transportation and storage. Therefore the probes must go through the complete cleaning and disinfection procedure before their first use.

Inspection before and after use must be performed as described below to ensure safe operation of the probe. If any abnormality is found, immediately stop using the probe and contact Mindray Customer Service Department or sales representative.

2.1 Appearance Inspection

Before and after each examination, confirm that there are no abnormalities of the probe surface or cable sheath, such as peeling, cracks, protruding parts, or looseness of the acoustic lens.

WARNING

Probe abnormalities may cause electric shock or injury to the patient. If any abnormality is found, immediately stop using the probe and contact Mindray Customer Service Department.

2.2 Use of Probe Sheath

Probe sheaths are available for use with all clinical situations where infection is a concern.

A sterile probe sheath is suggested to be used during intra-cavity examination or intra-operative examination.

Use a commercially available probe sheath.

To order probe sheath, contact:

CIVCO Medical Instruments Co.

102 First Street South, Kalona, IA 52247-9589 USA

Tel: 1-319-656-4447

E-mail: info@civco.com

<http://www.civco.com>

CAUTION

- **A probe sheath should be used once only to prevent infection.**

- **Use intact probe sheaths only.**
- **The probe sheath contains natural rubber latex and talc that can cause allergic reactions to some individuals.**
- **Use probe sheaths before the expiry date. Check if the probe sheath to be used is within the expiry period.**
- **Do not use pre-lubricated condoms as a sheath. Lubricant may not be compatible with the probe material and damage may result.**

2.3 Wearing the Probe Sheath

The method of using a probe sheath is shown as follows (for reference only):

1. Apply an appropriate amount of coupling gel inside the sheath or on probe surface. Poor imaging may occur if no gel is applied.

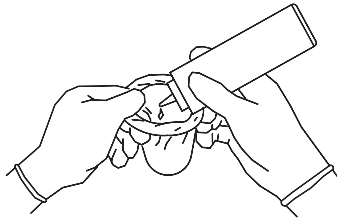

2. Use proper sterile technique to insert the probe into a probe sheath. Pull probe sheath tightly over probe surface to remove wrinkles and air bubbles, and take care to avoid puncturing cover.

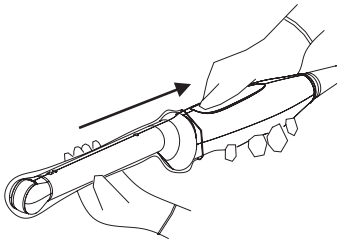

3. Secure the sheath with enclosed elastic bands.

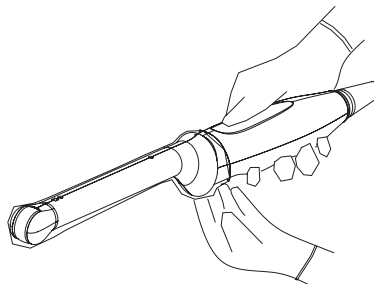

4. Inspect the sheath to ensure there are no holes or tears.

3 Cleaning, Disinfecting/Sterilizing Probes

After completing each examination, clean, disinfect or sterilize the probes as required. If necessary, repeat the cleaning, disinfection (or sterilization) process before next use. When biopsy procedures have been performed, be sure to sterilize the needle-guided bracket. Fail to do so may result in the probe and the needle-guided bracket to becoming sources of infection. Please follow the instructions in the manual for cleaning.

WARNING

Never immerse the probe connector into liquids such as water or disinfectant, for the connector is not waterproof. Immersion may cause electric shock or malfunction.

CAUTION

- **No cleaning and disinfecting may result in the probe becoming a source of infection.**
- **Please follow the disinfectant manufacturer's manual for performing cleaning and disinfection, including preparing sterile water and cleaning and disinfection time.**

NOTE:

- After the examination, wipe off the ultrasound gel thoroughly. Otherwise, the ultrasound gel may solidify and degrade the image quality of the probe.
- The probe surface temperature should not exceed the probe storage and transportation temperature specified in the user manual during cleaning and disinfections. High temperature may cause the probe to become deformed or damaged.
- Observe the illustration graph carefully to immerse the probe. Only soak parts of the probe below the strain relief.
- Repeated disinfection or sterilization will eventually damage the probe, please check the probe performance periodically.
- Clean the probe thoroughly in accordance with the cleaning procedure before disinfection or sterilization.
- For details about probe types, refer to the operator's manuals of the ultrasound system.
- For details about recommended disinfectants for probes, see "Appendix A Compatible Probe Cleaners and Disinfectants".
- For use of each disinfectant, please refer to the disinfectant manufacturer's instructions.
For V-PRO Low Temperature Sterilization System:

- The probe should be placed into a STERIS Sterilization Tray and wrapped with sterilization wrap. In Canada/FDA region, the STERIS Sterilization Tray and sterilization wrap should be cleared by the FDA/HC, such as H600 OneStep® sterilization wrap.
- Start the sterilization system using the Non Lumen Cycle according to the instructions provided by the sterilization device manufacturer.

3.1 Cleaning, Disinfection, and Sterilization Overview

Cleaning and disinfection refer to two distinct processes. According to the Centers for Disease Control and Prevention (CDC) “Guideline for Disinfection and Sterilization in Healthcare Facilities” (2008):

- Cleaning is the removal of visible soil (e.g. organic and inorganic material) from objects and surfaces and normally is accomplished manually or mechanically using water with detergents or enzymatic products. Thorough cleaning is essential before high-level disinfection and sterilization because inorganic and organic material that remains on the surfaces of instruments interfere with the effectiveness of these processes.
- Disinfection describes a process that eliminates many or all pathogenic microorganisms, except bacterial spores.
 - Low-Level Disinfection (LLD): Destruction of most bacteria, some viruses, and some fungi.
 - High-Level Disinfection (HLD): Destruction/removal of all microorganisms except bacterial spores.
- Sterilization describes a process that destroys or eliminates all forms of microbial life and is carried out in healthcare facilities by physical or chemical methods.

3.2 Selecting a Cleaning, Disinfection/Sterilization Method

Probes can be divided into three categories based on their intended use according to the standard ISO 17664. Some probes may fall into more than one category (e.g. probes use for biopsy procedures). When selecting a disinfectant, determine the required level of disinfection based on intended use and possibility of cross-contamination.

- Non-critical items: come into contact with intact skin only or are devices not intended for direct patient contact. Probes that only come into contact with clean, intact skin are considered noncritical devices and require cleaning after every use. Cleaning may be followed by a low-level disinfectant spray or wipe. For details, see "3.3 Processing Non-Critical Probes".
- Semi-critical items: come into contact with mucous membranes. This category includes all endocavity probes - transvaginal, transrectal, and transesophageal (TEE). These semi-critical probes must be cleaned with an appropriate cleaner after use followed by high-level disinfection. For details, see "3.4 Processing Semi-Critical Probes".
- Critical items: enter normally sterile parts of the human body. These probes are considered critical and include all intraoperative probes. These probes must be cleaned with an appropriate cleaner after each use, followed by a sterilization process. For details, see "3.5 Processing Critical Probes".

Figure 3-1 Workflow of selecting a processing method

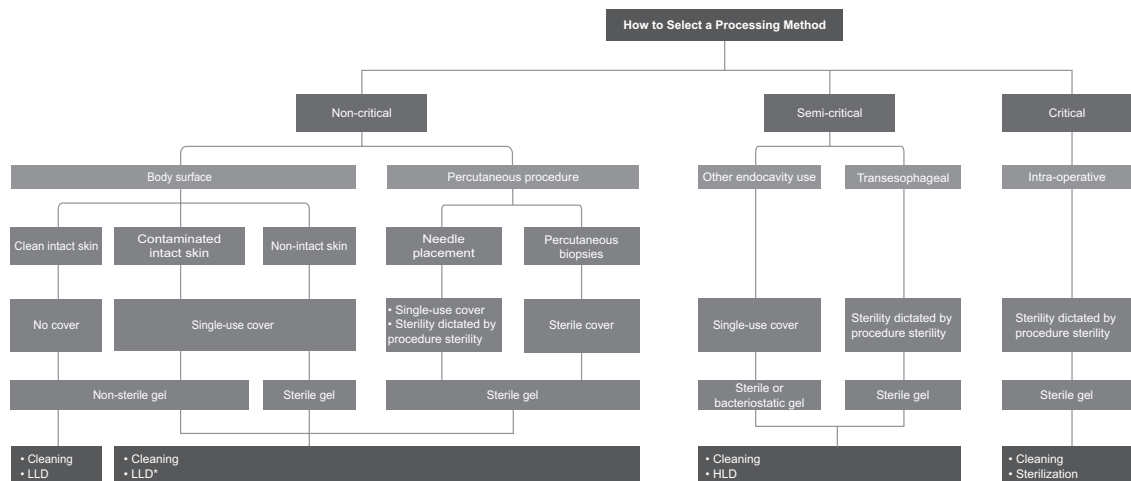

NOTE

LLD marked with * indicates that those categories must undergo low-level disinfectants that are effective against the mycobacteria and bloodborne pathogens. For details, consider referencing the position statement of the American Institute of Ultrasound in Medicine “Guidelines for Cleaning and Preparing External- and Internal-Use Ultrasound Transducers and Equipment Between Patients as well as Safe Handling and Use of Ultrasound Coupling Gel” at <https://www.aium.org/resources/official-statements/view/guidelines-for-cleaning-and-preparing-external--and-internal-use-ultrasound-transducers-and-equipment-between-patients-as-well-as-safe-handling-and-use-of-ultrasound-coupling-gel>.

3.3 Processing Non-Critical Probes

Processing of non-critical probes requires a two-step process: Cleaning of the probe followed by low-level disinfection.

⚠ WARNING

Use protective eyewear when disinfecting the probe using sprays.

Perform the following procedure:

1. Wear a pair of gloves to prevent infection through the whole processing.
2. Disconnect the probe from the system. If the sheath is used, take off the sheath and discard it.
3. Clean the probe.
 - a. Select an appropriate low-level disinfectant wipe or a piece of disposable lint-free soft cloth soaked with a disinfectant spray. For details about recommended disinfectants for probes, see "Appendix A Compatible Probe Cleaners and Disinfectants".
 - b. Thoroughly wipe all the surface starting from the probe head toward the probe cable. For details about the wiping time, refer to the wiping duration specified in the operator’s manual provided by the disinfectant manufacturer.

When necessary, clean and disinfect the seams or biopsy guide features by using disposable cotton swabs.

4. Disinfect the probe.

Prepare a new low-level disinfectant wipe or a piece of disposable lint-free soft cloth soaked with a disinfectant spray. Thoroughly wipe all the surface starting from the probe head toward the probe cable again. For details about the wiping time, refer to the wiping duration specified in the operator's manual provided by the disinfectant manufacturer.

5. Inspect the probe. If visible dirt still exists, repeat the preceding steps to wipe the probe until it is all clean.

6. Allow the probe to air dry in a clean and well-ventilated place or dry the probe with a piece of disposable lint-free soft cloth or tissue.

Do not dry the probe by heating.

7. Check whether the probe has defects such as peeling, rifts, bumps, cracks, or liquid spill. If such defects exist, the probe has reached the end of its service life. In this case, stop using it and contact the Mindray service department.

8. Store the probe in a cool, clean and dry environment.

3.4 Processing Semi-Critical Probes

Processing of semi-critical probes requires a two-step process: Cleaning of the probe followed by high-level disinfection.

For detailed information on the TEE cleaning and disinfection, see "4 Cleaning and Disinfecting the TEE Probe".

3.4.1 Before Processing

This step is to remove the ultrasound gel or other visible dirt.

1. Wear a pair of gloves to prevent infection through the whole processing.
2. Disconnect the probe from the system. If the sheath is used, take off the sheath and discard it. Wipe off the ultrasound gel or other visible dirt on the surface of the probe by using a damp piece of disposable lint-free soft cloth or tissue.

3.4.2 Cleaning

You can select wipes or detergent to clean the probe. For details about recommended cleaners or disinfectants for probes, see "Appendix A Compatible Probe Cleaners and Disinfectants".

Cleaning with Wipes

Perform the following procedure:

1. Use an approved cleaning or disinfectant wipe, cleaning sponge, or a disposable lint-free soft cloth soaked in approved cleaner or disinfectant. Thoroughly wipe all the surface starting from the probe head toward the probe cable for at least 1 minute or according to cleaner manufacturer's instructions.

When necessary, clean and disinfect the seams or biopsy guide features by using disposable cotton swabs.

Some disinfectant wipes or sprays can be used for cleaning.

2. Dry the probe with a piece of disposable lint-free soft cloth or tissue.
Do not dry the probe by heating.
3. Inspect the probe. If visible dirt still exists, repeat the preceding steps to wash the probe until it is all clean.

Cleaning with Detergent

Perform the following procedure:

1. Choose an appropriate cleaning agent including mild detergents, and enzymatic.
2. Immerse the probe head fully in the cleaning fluid for at least 1 minute or according to cleaner manufacturer's instructions. Use a disposable lint-free soft cloth soaked in the approved cleaning fluid to thoroughly wipe the cable surface. Lightly clean the probe head with a piece of disposable lint-free soft cloth or soft sponge until no dirt is visible. When necessary, clean the seams or biopsy guide features by using disposable cotton swabs. Avoid using a brush to wash the lens because it may damage the probe.

Observe the graph here carefully to immerse the probe. Only soak parts of the probe below the strain relief.

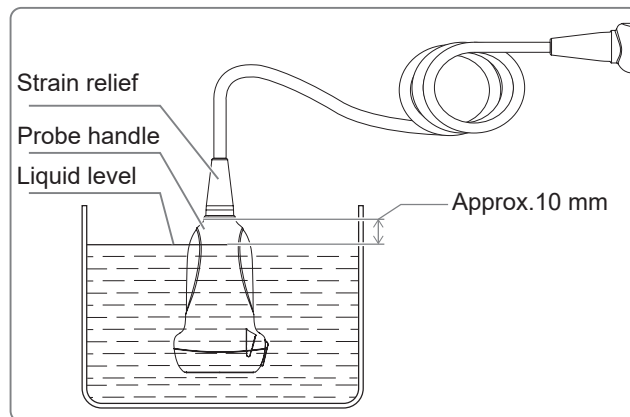

3. Rinse the probe thoroughly by using a large amount of clean water (about 7.5 L/2 gallons) at room temperature for about 1 minute to remove the residual dirt and cleaning solvent.
4. Dry the probe with a piece of disposable lint-free soft cloth or tissue.
Do not dry the probe by heating.
5. Inspect the probe. If visible dirt still exists, repeat the preceding steps to wash the probe until it is all clean.

3.4.3 High-Level Disinfection

You can disinfect the probe by using an appropriate high-level disinfectant solution or device. For details about recommended disinfectants or devices for probes, see "Appendix A Compatible Probe Cleaners and Disinfectants".

Some disinfectants in the form of wipe or spray can be used for high-level disinfection.

Disinfection with Reagent (Solution/Wipe/Spray)

Perform the following procedure:

1. Follow the operator's manual provided by the disinfectant manufacturer to disinfect the probe using a high-level disinfectant.

2. Prepare a disinfectant by using sterile distilled or softened water when necessary.
 - Soaking: Immerse the probe head in the disinfectant and shake the probe appropriately to remove any bubbles on the probe surface. For details about the probe immersion duration, see the operator's manual provided by the disinfectant manufacturer.

Observe the graph here carefully to immerse the probe. Only soak parts of the probe below the strain relief.

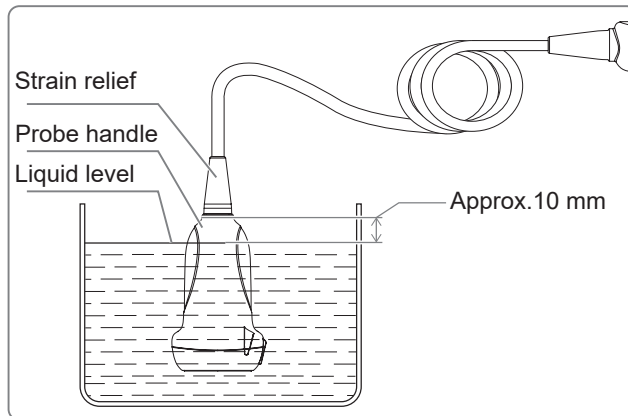

- Wiping: Use a market disinfection wipe product or disposable lint-free soft cloth wetted with disinfection spray. Thoroughly wipe all the surface starting from the probe head toward the probe cable for a duration according to the disinfectant manufacturer instructions.
3. Rinse the probe thoroughly by using a large amount of clean water (about 7.5 L/2 gallons) at room temperature for about 1 minute to remove the residual disinfectant. Or follow the disinfectant manufacturer's instructions regarding rinsing. Dry the probe with a piece of disposable lint-free soft cloth or tissue.

Do not dry the probe by heating.
 4. Check whether the probe has defects such as peeling, rifts, bumps, cracks, or liquid spill. If such defects exist, the probe has reached the end of its service life. In this case, stop using it and contact the Mindray service department.
 5. Store the probe in a cool, clean and dry environment.

Disinfection with Device

Perform the following procedure:

1. Follow the operator's manual provided by the disinfection device manufacturer to disinfect the probe using a device.
2. After disinfection, check whether the probe has defects such as peeling, rifts, bumps, cracks, or liquid spill. If such defects exist, the probe has reached the end of its service life. In this case, stop using it and contact the Mindray service department.
3. Store the probe in a cool, clean and dry environment.

3.5 Processing Critical Probes

Processing of critical probes requires a two-step process: Cleaning of the probe followed by sterilization.

For detailed information on the laparoscopic cleaning and disinfection, see "5 Cleaning and Sterilizing the Laparoscopic Probe".

3.5.1 Before Processing

This step is to remove the ultrasound gel or other visible dirt.

1. Wear a pair of gloves to prevent infection through the whole processing.
2. Disconnect the probe from the system. If the sheath is used, take off the sheath and discard it. Wipe off the ultrasound gel or other visible dirt on the surface of the probe by using a damp piece of disposable lint-free soft cloth or tissue.

3.5.2 Cleaning

Select wipes or detergent to clean the probe. For details about recommended cleaners or disinfectants for probes, see "Appendix A Compatible Probe Cleaners and Disinfectants".

Cleaning with Wipes

Perform the following procedure:

1. Use an approved cleaning or disinfectant wipe, cleaning sponge, or a disposable lint-free soft cloth soaked in approved cleaner or disinfectant. Thoroughly wipe all the surface starting from the probe head toward the probe cable for at least 1 minute or according to cleaner manufacturer's instructions.

When necessary, clean and disinfect the seams or biopsy guide features by using disposable cotton swabs.

Some disinfectant wipes or sprays can be used for cleaning.

2. Dry the probe with a piece of disposable lint-free soft cloth or tissue.

Do not dry the probe by heating.

3. Inspect the probe. If visible dirt still exists, repeat the preceding steps to wash the probe until it is all clean.

Cleaning with Detergent

Perform the following procedure:

1. Choose an appropriate cleaning agent including mild detergents, and enzymatic.
2. Immerse the probe head fully in the cleaning fluid for at least 1 minute or according to cleaner manufacturer's instructions. Use a disposable lint-free soft cloth soaked in the approved cleaning fluid to thoroughly wipe the cable surface. Lightly clean the probe head with a piece of disposable lint-free soft cloth or soft sponge until no dirt is visible. When necessary, clean the seams or biopsy guide features by using disposable cotton swabs. Avoid using a brush to wash the lens because it may damage the probe.

Observe the graph here carefully to immerse the probe. Only soak parts of the probe below the strain relief.

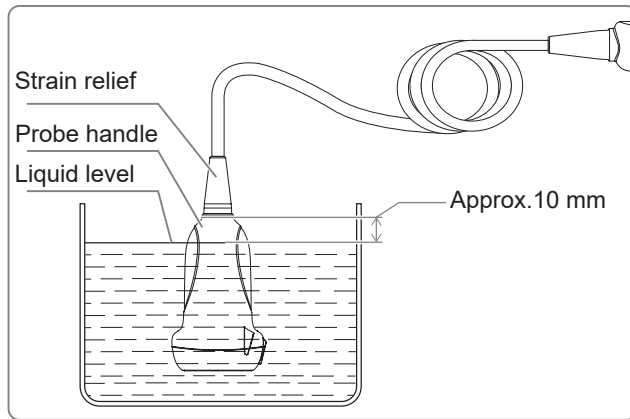

3. Rinse the probe thoroughly by using a large amount of clean water (about 7.5 L/2 gallons) at room temperature for about 1 minute to remove the residual dirt and cleaning solvent.
4. Dry the probe with a piece of disposable lint-free soft cloth or tissue.
Do not dry the probe by heating.
5. Inspect the probe. If visible dirt still exists, repeat the preceding steps to wash the probe until it is all clean.

3.5.3 Sterilization

For intra-operative probes, they have to be thoroughly cleaned and sterilized after completing each examination.

You can sterilize the probe by using an appropriate sterilant or device. For details about recommended sterilants or devices for probes, see "Appendix A Compatible Probe Cleaners and Disinfectants".

Sterilization with Sterilant

Perform the following procedure:

1. Follow the operator's manual provided by the sterilant manufacturer to sterilize the probe using a sterilant.
2. Prepare a sterilant by using sterile distilled or softened water when necessary.
3. Immerse the probe head in the sterilant and shake the probe appropriately to remove any bubbles on the probe surface.

For details about the probe immersion duration, see the operator's manual provided by the sterilant manufacturer.

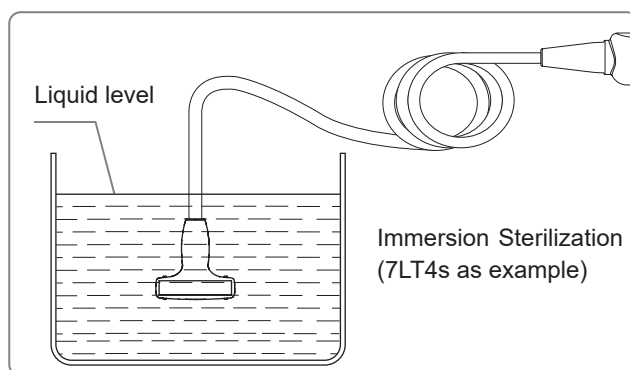

4. Rinse the probe thoroughly by using a large amount of sterile distilled or softened water (about 7.5 L/2 gallons) at room temperature for about 1 minute to remove the residual sterilant. Or follow the sterilant manufacturer's instructions regarding rinsing. Dry the probe with a piece of sterile disposable lint-free soft cloth.

Do not dry the probe by heating.

5. Check whether the probe has defects such as peeling, rifts, bumps, cracks, or liquid spill. If such defects exist, the probe has reached the end of its service life. In this case, stop using it and contact the Mindray service department.
6. Store the probe in a cool, clean and dry environment.

Sterilization with Device

Perform the following procedure:

1. Follow the operator's manual provided by the sterilization device manufacturer to sterilize the probe using a device.
2. After sterilization, check whether the probe has defects such as peeling, rifts, bumps, cracks, or liquid spill. If such defects exist, the probe has reached the end of its service life. In this case, stop using it and contact the Mindray service department.
3. Store the probe in a cool, clean and dry environment.

This page intentionally left blank.

4 Cleaning and Disinfecting the TEE Probe

This section describes the methods and precautions for cleaning and disinfection of TEE probes. After completing each examination, clean, disinfect the TEE probes as required. If necessary, repeat the cleaning, disinfection process before next use.

WARNING

- **Keep the control handle and system connector out of any cleaning or disinfection solutions. The control handle and cable may be cleaned with a damp cloth, but only the distal end of the transducer up to the 1m marker on the shaft (70 cm for P8-3Ts/XP7-2TU) may be placed into a disinfection solution.**
- **Do not use other disinfection methods like Iodine, Steam, Heat or Ethylene Oxide.**
- **To avoid injury to the patient, you must follow the manufacturer's recommendation for rinsing.**

CAUTION

- **To avoid damaging the transducer, the transducer should not be exposed to the disinfectant longer than specified to achieve the desired effect, but never longer than one hour.**
- **To avoid damaging the transducer, do not steam autoclave or subject the transducer to Ethylene Oxide (ETO).**
- **To avoid damaging the transducer, do not immerse the transducer in a solution containing ethanol.**
- **After disinfection, rinse the transducer thoroughly with clean water to remove all chemical residues. Chemical residues on the transducer may be harmful to the human body.**
- **The efficacy of disinfectants solutions is not guaranteed by MINDRAY. Contact the manufacturers for information on the activity of the products.**

NOTE:

- **After the examination, wipe off the ultrasound gel thoroughly, otherwise, the ultrasound gel may solidify and degrade the image quality of the transducer.**
- **Do not permit the transducer to become overheated (more than 55°C) during cleaning and disinfections. High temperature may cause the transducer to become deformed or damaged.**
- **Clean the probe thoroughly in accordance with the cleaning procedure before disinfection.**

4.1 Before Processing

- Wear protective devices such as surgical caps, masks, gloves, goggles or face shield, and dedicated lab suit when cleaning and disinfecting the TEE probe.
- After using the probe, freeze the image, power off the ultrasound system, and disconnect the probe from the ultrasound system, to prevent data loss due to hot plug. If the sheath is used, take off the sheath and dispose it as directed by the hospital. Cleaning and disinfection are required even if the sheath is used.

This step is to remove the ultrasound gel or other visible dirt.

1. Wipe away the ultrasound gel or other visible dirt on the surface of the probe by using a damp piece of disposable lint-free soft cloth or tissue.
2. Rinse the probe insertion part under flowing water for about 1 minute to preliminarily remove the contaminants from the probe surface.
3. Place the contaminated probe in an appropriate hard transport container and transport it to the decontamination room. During transportation, avoid over bending the insertion part (the bending diameter cannot be smaller than 30cm), and avoid colliding or squeezing the probe. Do not touch the acoustic head with heavy objects. Transport in a timely manner so as to avoid allowing bodily fluids to dry on the probe's surface

4.2 Cleaning

Perform the following procedure:

1. Select an appropriate cleaner include cleaning wipes and sprays, mild detergents, enzymatic cleaners and specially designed enzymatic sponges. For details, see "4.4 Validated Cleaner and Disinfectant/Disinfection System". Follow the cleaner manufacturer's instructions to prepare and use the cleaner.
2. Select an appropriate method:
 - Soaking: Soak the probe in the cleaner solution for a duration according to the cleaner manufacturer's instructions. Wipe and wash the probe surface gently by using a piece of lint-free soft cloth or soft sponge until no dirt is visible. When necessary, wash the locating groove and other items by using disposable cotton swabs.

Avoid using a brush to wash the lens because it may damage the probe.

Only the section from distal end to the 1m marker (70 cm for pediatric TEE probe) on the flexible shaft can be immersed in the cleaner solution. The handle, cable and connector can only be cleaned with a wrung out soft cloth moistened with cleaners.
 - Wiping: Use a commercially available cleaning wipe, cleaning sponge, or a soft cloth soaked with a cleaning spray to wipe and clean all surfaces of the probe thoroughly for at least 1 minute or follow the cleaner manufacturer's instructions until the probe is clean. When necessary, wash the locating groove and other items by using disposable cotton swabs.
3. Rinse the probe insertion part thoroughly with plenty of clean flowing water (about 7.5L) at room temperature for about 1 minute to remove the residual dirt and cleaning solvent. Or follow the rinsing method specified by the cleaner manufacturer. Use moistened soft cloth to wipe the residual cleaners on the handle, cable, and connector.
4. Dry the probe with a disposable lint-free soft cloth or tissue.

Do not dry the probe by heating.

5. Inspect the probe. If visible dirt still exists, repeat the preceding steps to wash the probe until it is all clean.

4.3 Disinfection

NOTES:

- Clean the probe thoroughly in accordance with the cleaning procedure before disinfection.
- Disinfection using systems or disinfectant both can achieve disinfection effect. You can select an appropriate disinfection method as required.

4.3.1 Disinfection using Disinfectant

Perform the following procedure:

1. Select an appropriate high-level disinfectant to disinfect the probe. For details, see "4.4 Validated Cleaner and Disinfectant/Disinfection System". Follow the disinfectant manufacturer's instructions to use the high-level disinfectant. Prepare a disinfectant by using sterile distilled or softened water when necessary.
2. Select an appropriate method:
 - Soaking: Soak the probe in the disinfectant solution and shake the probe properly to remove bubbles on the surface of the probe. For the probe soaking duration, see the disinfectant manufacturer's instructions.

Only the section from distal end to the 1m marker (70 cm for pediatric TEE probe) on the flexible shaft can be immersed in the disinfectant solution. The handle, cable and connector can only be disinfected with a wrung out soft cloth moistened with disinfectants.
 - Wiping: Use a commercially available disinfecting wipe, or a disposable sterile lint-free soft cloth soaked with a disinfecting spray to wipe and disinfect all surfaces of the probe thoroughly for the time specified in the disinfectant manufacturer's instructions.
3. Rinse the probe insertion part thoroughly with plenty of clean flowing water (about 7.5L) at room temperature for about 1 minute to remove the residual dirt and disinfectants. Or follow the rinsing method specified by the disinfectant manufacturer. Use moistened soft cloth to wipe the residual disinfectants on the handle, cable, and connector.
4. Dry the probe with a disposable lint-free soft cloth or tissue.

Do not dry the probe by heating.
5. Check whether the probe has defects such as peeling, rifts, bumps, cracks, or liquid spill. If such defects exist, the probe has reached the end of its service life. In this case, stop using it and contact the Mindray service department.
6. Store the probe in a cool and dry environment.

CAUTION

- **The lens may be discolored; the label on the transducer may fade. These are not abnormalities.**

- Repeated disinfection will eventually damage the transducer, please check the transducer's performance periodically.
- Disinfecting incorrectly or with chemicals not recommended by Mindray will void the warranty.

4.3.2 Disinfection using Disinfection System

For details, see "4.4 Validated Cleaner and Disinfectant/Disinfection System". For details about using the disinfection system, refer to the disinfection system manufacturer's instructions.

WARNING

To avoid injury to the patient, if residue from the disinfectant is not removed it can cause irritation and/or burning of the mouth and esophageal tissue.

4.4 Validated Cleaner and Disinfectant/Disinfection System

The manual release time is different from the version update time of the Mindray product, so the list in this manual may not be the latest version. If you cannot find the information in this list, contact Mindray Customer Service Department or sales representative.

Only the following cleaners, disinfectants, and disinfection systems are recommended by Mindray to clean and disinfect the TEE transducers. For the biological effectiveness and the correct use of the cleaners, disinfectants, and disinfection systems, see the information provided by the manufacturer.

4.4.1 Cleaner

List of Cleaners

Item	P7-3T/P7-3Ts/ P7-3TU/P7-3TE	P8-3Ts	P8-2Ts/ P8-2TU	XP8-2TU	XP7-2TU
Cidezyme/Enzol	√	√	√	√	√
Neodisher MediClean forte	√	√	√	√	√
Prolystica 2X Concentrate Enzymatic Presoak and Cleaner	√	√	√	√	√
EmPower	√	√	√		
MetriZyme	√	√	√		
WIP'ANIOS CLEAN'UP			√		
Intercept Detergent			√		
TEEZyme				√	√
TEEZyme Sponge				√	√

Active Ingredients

Cleaner	Active ingredient	Concentration
Cidezyme/Enzol	Proteolytic enzymes	< 5%

Cleaner	Active ingredient	Concentration
Neodisher MediClean forte	Trisodium nitrilotriacetate	5-10%
	2,2-Iminodiethanol diethanolamine	1-2%
Prolystica 2x conc. Enzymatic Presoak & cleaner	Ethanolamine	1-5%
	Protease	0.1-1%
	Ethoxylated alcohol	1-5%
	Polyalkylene glycol	1-5%
	Glycerine	1-5%
EMpower	Proteolytic enzymes	< 2%
Metrizyme	Proteolytic enzymes	< 2%
WIP'ANIOS CLEAN'UP	Association of surfactants, excipients	/
Intercept™ Detergent	Diethylene glycol monoethyl ether, Quaternary ammonium compounds, benzyl-C12-18-alkyldimethyl, chlorides	1-5%
TEEZyme	Ethoxylated Alcohols	0.1-1%
	Proteolytic enzymes	0.1-1%
	Amylase	0.1-0.5%
TEEZyme Sponge	Proteolytic enzymes	0.1-1%

4.4.2 Disinfectant

List of Disinfectants

Item	P7-3T/P7-3Ts/ P7-3TU/P7-3TE	P8-3Ts	P8-2Ts/ P8-2TU	XP8-2TU	XP7-2TU
Cidex Activated Dialdehyde Solution	√	√	√		
Wavicide 01	√	√	√		
Gigasept Instru AF	√	√			
Gigasept FF (neu)	√	√			
gigasept PAA concentrate	√	√			
MetriCide Plus 30	√	√			
Perasafe	√	√			
MetriCide	√	√	√		
MetriCide 28	√	√	√		
Steranios 2%, 2% N.G., 2% E.C.S.	√	√	√		
CIDEX OPA	√	√	√	√	√
MetriCide OPA Plus	√	√	√	√	√
TD5	√	√	√	√	√
Rapicide PA HLD		√	√	√	√
Revital-Ox Resert High Level Disinfectant	√	√		√	√

Item	P7-3T/P7-3Ts/ P7-3TU/P7-3TE	P8-3Ts	P8-2Ts/ P8-2TU	XP8-2TU	XP7-2TU
Tristel Trio Wipes System	√	√		√	√
UltrOx High-Level disinfectant	√	√		√	√
ANIOXYDE 1000			√		
Rapicide OPA-28			√		
TD-8				√	√
TD-12 AquaCide				√	√

Active Ingredients

Disinfectant	Active ingredient	Concentration
Cidex Activated Dialdehyde Solution	Glutaraldehyde	2.4%
Wavicide 01	Glutaraldehyde	2.65%
Gigasept AF	Didecyldimethylammoniumchloride	15%
	Glycine, aminoalkyl derivs	6.9%
	Tridecylpolyethyleneglycoether	15-30%
	N-(3-Aminopropyl)-N-dodecylpropane-1,3- diamine	< 5%
Gigasept FF (neu)	Dimethoxytetrahydrofuran	3.2%
	Succindialdehyde	11.9%
	Ethanol	5-15%
	Methanol	5-10%
	Alkylpolyethylenglykolpolypropyleneglycol-ether, 2-ethanol, 3,6-dioxa-1-dodecanol, 3,6-dioxadodecan-1-ol, DEGHE, diethylene glycol monohexyl ether, hexyl carbitol	1-5%
Gigasept PAA concentrate	Peracetic Acid	5%
	Hydrogen peroxide	10-20%
	Acetic Acid	10-20%
Metricide Plus 30	Glutaraldehyde	3.40%
Perasafe	Sodium Perborate	40-60%
Metricide	Glutaraldehyde	2.60%
Metricide 28	Glutaraldehyde	2.50%
Steranios 2%, 2% N.G., 2% E.C.S.	Glutaraldehyde	2.00%
CIDEX® OPA	Ortho-phthalaldehyde	0.55%
Metricide OPA Plus	Ortho-phthalaldehyde	0.60%
TD5	Glutaraldehyde	2.65%

Disinfectant	Active ingredient	Concentration
Rapicide PA HLD	Peracetic Acid	5%
	Hydrogen Peroxide	22%
	Trisodium Phosphate	4.3%
	Surfactant	4%
Revital-Ox [®] Resert [®] HLD	Hydrogen Peroxide	1.4-2.3%
	2-Furoic Acid	≤2.50
Tristel Trio Wipes	Propan-2-OL	1-10%
	Polymeric Biguanide Hydrochloride	< 1%
	5-Chloro-2-Isothiazol-3-one	< 1%
	2-Methyl-2H-Isothiazol-3-O Chlorinedioxide	< 1%
	Sodiumchlorite 100%	< 1%
UltrOx [™] HLD	Hydrogen Peroxide	1.4-2.3%
	2-Furoic Acid	≤2.50
ANIOXYDE 1000	Hydrogen peroxide	3%
Rapicide OPA-28	Ortho-phthalaldehyde	0.575%
TD-8	Ortho-phthalaldehyde	0.59%
TD-12 AquaCide	Peracetic Acid	3000ppm

4.4.3 Disinfection System

Item	Description	Manufacturer	Applicable Probe
Germitec UV-C	Photonic Disinfection by UV light	Germitec	XP7-2TU

4.5 Recommended Automated Reprocessor (AR)

The AR devices can be used for automated probe cleaning and (or) disinfection.

NOTE:

- This guide details only the manual cleaning and disinfection of probes. Refer to the accompanying instructions for detailed operation information of an AR, such as reprocessing conditions.
- For the AR that claims only disinfectants, manual cleaning is required prior to automated disinfection.
- To purchase an AR, contact the AR manufacturer.

The recommended ARs are as follows:

Model	Manufacturer	Compatible Reagents	P7-3T/P7-3Ts/ P7-3TU/P7-3TE	P8-3Ts	P8-2Ts/ P8-2TU	XP8-2TU/ XP7-2TU
ASTRA TEE	CIVCO Medical Solutions	CIDEX OPA	√	√	√	√
		MetriCide OPA Plus	√	√	√	√
		Revital- Ox Resert High Level Disinfectant	√	√		√
		UltrOx High-Level disinfectant	√	√		√
Advantage Plus	Steris (Medivators)	Intercept Detergent			√	
		Rapicide PA HLD		√	√	√

5 Cleaning and Sterilizing the Laparoscopic Probe

This section describes the methods and precautions for cleaning and sterilization of laparoscopic probes. After completing each examination, clean, sterilize the laparoscopic probes as required. If necessary, repeat the cleaning, sterilization process before next use.

WARNING

- **Keep the control handle and system connector out of any cleaning or sterilant solutions. The control handle and cable may be cleaned with a damp cloth, but only the distal end of the transducer up to the hard shaft (under the strain relief) may be placed into a sterilant solution.**
- **To avoid injury to the patient, you must follow the manufacturer's recommendation for rinsing.**
- **If the probe is not cleaned and sterilized, it may become the source of infection.**

CAUTION

- **To avoid damaging the transducer, the transducer should not be exposed to the sterilant longer than specified to achieve the desired effect.**
- **To avoid damaging the transducer, do not immerse the transducer in a solution containing ethanol.**
- **After sterilization, rinse the transducer thoroughly with sterile distilled water to remove all chemical residues. Chemical residues on the transducer may be harmful to the human body.**
- **The laparoscopic probe, as a critical probe, must undergo cleaning and sterilization completely after each use.**

NOTE:

- **After the examination, wipe off the ultrasound gel thoroughly, otherwise, the ultrasound gel may solidify and degrade the image quality of the transducer.**
- **Do not permit the transducer to become overheated (more than 55°C) during cleaning and sterilization. High temperature may cause the transducer to become deformed or damaged.**

5.1 Before Processing

This step is to remove the ultrasound gel or other visible dirt.

Perform the following procedure:

1. Wear protective devices such as surgical caps, masks, gloves, goggles or face shield, and dedicated lab suit when cleaning and sterilizing the laparoscopic probe.
2. After using the probe, freeze the image, power off the ultrasound system, and disconnect the probe from the ultrasound system, to prevent data loss due to hot plug. If the sheath is used, take off the sheath and dispose it as directed by the hospital. Cleaning and sterilization are required even if the sheath is used.
3. Wipe away the ultrasound gel or other visible dirt on the surface of the probe by using a damp piece of disposable lint-free soft cloth or tissue.
4. Place the contaminated probe in probe container and transport it to the decontamination room. During transportation, avoid colliding or squeezing the probe. Do not touch the acoustic head with heavy objects. Keep the probe moist during transportation to prevent body fluid from drying up on the probe surface. If cleaning cannot be performed immediately, immerse the insertion part of the probe in the detergent or water to avoid drying for more than 30 minutes.

The probe must be placed along the placement guide line that is laser carved at the bottom of the probe container. To order the probe container, contact Mindray.

If users select its own probe container, refer to the following dimension of the Mindray customized probe container:

624 ±2 mm (length) * 340 ±1 mm (width) *75±1 mm (height)

5.2 Cleaning

Perform the following procedure:

1. Select an appropriate cleaner. For details, see "5.4.1 Validated Cleaner and Sterilant/ Sterilization System".
2. Follow the cleaner manufacturer's instructions to prepare and use the cleaner. Select an appropriate method:
3. Clean the insertion part: soak the probe insertion part thoroughly in the cleaner solution for at least 5 minutes or follow the cleaner manufacturer's instructions.
4. Wipe and wash the probe surface gently by using a piece of lint-free soft cloth or soft sponge until no dirt is visible. When necessary, wash the locating groove and other items by using disposable cotton swabs. Avoid using a brush to wash the lens because it may damage the probe.

Only the section from the distal end to the part under the handle (probe insertion part) can be immersed in the cleaner solution. The handle, cable and connector can only be cleaned with a wrung out soft cloth moistened with cleaners.

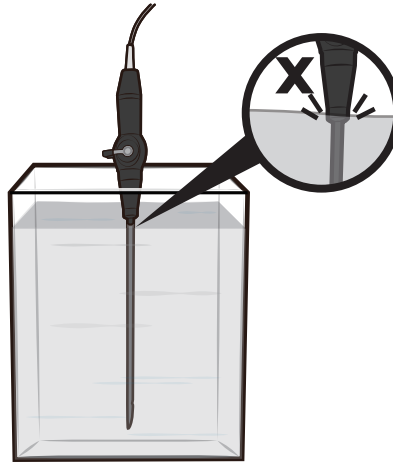

5. Clean other parts (except for the insertion part): use a disposable soft cloth soaked with cleaner solution and screw it dry until no liquids drip to wipe the strain relief, control handle, deflection lever, cable, and probe connector for at least 1 minute or follow the cleaner manufacturer's instructions until the probe is clean.

Avoiding touching the internal pins of the connector with any cleaner.

6. Rinse the probe insertion part thoroughly with plenty of clean flowing water (about 7.5L) at room temperature for about 1 minute to remove the residual dirt and cleaner solution. Or follow the rinsing method specified by the cleaner manufacturer. Use moistened dust-free soft cloth to wipe the residual dirt or cleaners on the parts except for the insertion part.
7. Dry the probe with a disposable lint-free soft cloth or tissue.
Do not dry the probe by heating.
8. Inspect the probe. If visible dirt still exists, repeat the preceding steps to clean the probe until it is all clean.
9. Check whether the probe has defects such as peeling, rifts, bumps, cracks, or liquid spill. If such defects exist, the probe has reached the end of its service life. In this case, stop using it and contact the Mindray service department.

5.3 Sterilization

NOTES:

- Clean the probe thoroughly in accordance with the cleaning procedure before sterilization.
- Sterilization using systems or sterilant both can achieve sterilization effect. You can select an appropriate sterilization method as required.

5.3.1 Sterilization using Sterilization System

This chapter only introduces the basic operation procedures of the sterilization system. For details about using the sterilization system, refer to the sterilization system manufacturer's instructions.

Sterilization using V-PRO Low Temperature Sterilization System

Perform the following procedure:

1. Place the probe into a clean probe container and wrap the probe container including probe with sterilization wrap which had already cleared by the authorities such as H600 OneStep® sterilization wrap.
2. Start the V-PRO Low Temperature Sterilization System using the Non Lumen Cycle according to the instructions provided by the sterilization system manufacturer.
3. Keep the sterilization wrap together with other sterilized surgical instruments in a sterile item storage area.
4. Before next use, check whether the probe has defects such as peeling, rifts, bumps, cracks, or liquid spill. If such defects exist, the probe has reached the end of its service life. In this case, stop using it and contact the Mindray service department.

Sterilization using STERRAD Low Temperature Sterilization System

Perform the following procedure:

1. Place the probe into a clean probe container and wrap the probe container including probe with sterilization wrap which had already cleared by the authorities such as Halyard Health Sterilization Wrap H400.
2. Start the STERRAD Low Temperature Sterilization System using the STANDARD Cycle according to the instructions provided by the sterilization system manufacturer.
3. Keep the sterilization wrap together with other sterilized surgical instruments in a sterile item storage area.
4. Before next use, check whether the probe has defects such as peeling, rifts, bumps, cracks, or liquid spill. If such defects exist, the probe has reached the end of its service life. In this case, stop using it and contact the Mindray service department.

5.3.2 Sterilization using Solution

Perform the following procedure:

1. Select an appropriate sterilant to sterilize the probe. For detail, see "5.4.1 Validated Cleaner and Sterilant/Sterilization System".
2. Follow the sterilant manufacturer's instructions to prepare and use the sterilant. Prepare a sterilant by using sterile distilled or softened water when necessary.
3. Soak the probe insertion part in the sterilant solution and shake the probe properly to remove bubbles on the surface of the probe. For the probe soaking duration, see the sterilant manufacturer's instructions.

Only the section from the distal end to the part under the handle (probe insertion part) can be immersed in the sterilant solution. The handle, cable and connector can only be sterilized with a wrung out soft cloth moistened with sterilant.

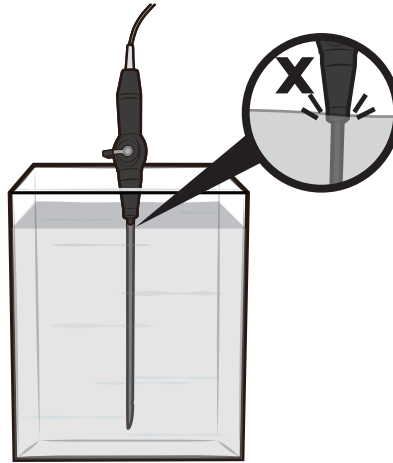

4. Rinse the probe insertion part thoroughly with plenty of sterile distilled water (about 7.5L) at room temperature for about 1 minute to remove the residual sterilant. Or follow the rinsing method specified by the sterilant manufacturer.
5. Dry the probe with a piece of disposable sterile lint-free soft cloth.
Do not dry the probe by heating.
6. Check whether the probe has defects such as peeling, rifts, bumps, cracks, or liquid spill. If such defects exist, the probe has reached the end of its service life. In this case, stop using it and contact the Mindray service department.
7. Store the probe in the sterilized probe container.
If necessary, repeat the cleaning, sterilization process before next use.

CAUTION

- The lens may be discolored; the label on the transducer may fade. These are not abnormalities.
- Repeated sterilization will eventually damage the transducer, please check the transducer's performance periodically.
- Sterilizing incorrectly or with chemicals not recommended by Mindray will void the warranty.

5.4 List of Cleaner, Disinfectant and Sterilant/Sterilization System

The manual release time is different from the version update time of the Mindray product, so the list in this manual may not be the latest version. If you cannot find the information in this list, contact Mindray Customer Service Department or sales representative.

5.4.1 Validated Cleaner and Sterilant/Sterilization System

Only the following cleaners, and sterilant/sterilization system are validated by Mindray to clean and sterilize the laparoscope transducers. For the biological effectiveness and the correct use, see the information of the cleaners, and sterilant/sterilization system manufacturers.

Cleaner

Item	Active ingredient	Concentration
MetriZyme	Proteolytic enzymes	< 2%
Liquinox	Benzenesulfonic acid, mono-C10-16-alkyl derivs., sodium salts	10-30%
	Alcohols, C12-14-secondary, ethoxylated	3-7%
Prolystica 2X Concentrate Enzymatic Presoak and Cleaner	Ethanolamine	1-5%
	Protease	0.1-1%
	Ethoxylated alcohol	1-5%
	Polyalkylene glycol	1-5%
	Glycerine	1-5%
DDN9	N PROPIONATE ,N-DIDECYL—N-METHYL-POLY{OXYETHYL)AMMONIUM	2.5≤X%<10
	TETRAPOTASSIUM	2.5≤X%<10
	ETHYLENEDIAMINETETRAACETATE	
	EDETIC ACID (EDTA)	0≤X%<2.5

Sterilant

Item	Active ingredient	Concentration
Cidex Activated Dialdehyde Solution	Glutaraldehyde	2.4%

Sterilization System

Item	Cycle
V-PRO Low Temperature Sterilization System (Used with Vaporized Hydrogen Peroxide)	Non Lumen Cycle
STERRAD 100NX Sterilizer with ALLClear Technology	STANDARD Cycle

5.4.2 Material Compatible Disinfectant

Item	Active ingredient	Concentration
ANIOXYDE 1000	Hydrogen peroxide	3%
Anios Clean Excel D	Alcohols, C8-10, ethoxylated	≥ 5 - < 10
	Didecyl Dimethyl Ammonium Chloride	≥ 5 - < 10
	Isopropyl Alcohol	≥ 2.5 - < 5
Bodedex Forte	propane-1,2-diol	≥ 10 - < 20
	Tridecanol, branched, ethoxylated	≥ 3 - < 10
	Alcohols, C12-14. ethoxylated	≥ 3 - < 10
	Quaternary ammonium compounds, [2-[[2-[(2- carboxyethyl)(2-hydroxyethyl) am i no]ethyl]am i no]-2-oxoethyl]coco alkyldimethyl, hydroxides,	≥ 1 - < 2,5
CIDEX OPA	Ortho-phthalaldehyde	0.55%

Item	Active ingredient	Concentration
Gigasept Instru AF	Didecyldimethylammoniumchloride	15%
	Glycine, aminoalkyl derivs	6.9%
	Tridecylpolyethyleneglycolether	15-30%
	N-(3-Aminopropyl)-N-dodecylpropane-1,3-diamine	< 5%
Korsolex Extra	Glutaral	≥ 5 - < 10
	Formaldehyde	≥ 5 - < 10
	(ethylenedioxy)dimethanol	≥ 3 - < 10
	Propan-2-ol	≥ 1 - < 10
	Octan-1-ol, ethoxylated	≥ 3 - < 5
	Tridecanol, branched, ethoxylated	≥ 3 - < 10
	[[[(2-hydroxyethyl)imino]bis(methylene)]bisphosphonic acid	≥ 1 - < 2,5
	Didecyldimethylammonium chloride	≥ 1 - < 2,5
	Alkyl (C12-18) dimethylbenzyl ammonium chloride (ADBAC (C12-18))	≥ 1 - < 2,5
	N-(2-ethylhexyl)-3,5,5-trimethylhexanamide	≥ 0,25 - < 1
Perasafe	Sodium Perborate	40-60%
Revital-Ox Resert High Level Disinfectant	Hydrogen Peroxide	1.4-2.3%
	2-Furoic Acid	≤2.50
UltrOx High-Level disinfectant	Hydrogen Peroxide	1.4-2.3%
	2-Furoic Acid	≤2.50
Sani-Cloth HB Germicidal Disposable Wipe	Alkyl dimethyl benzyl ammonium chloride	0.07%
	Alkyl dimethyl ethylbenzyl ammonium chloride	0.07%
Sekusept Aktiv	odium Percarbonate	30 - 50%
	Citric acid	10 - 20%
	sodium carbonate	2 - 5%
Tristel Trio Wipes System	Propan-2-OL	1-10%
	Polymeric Biguanide Hydrochloride	< 1%
	5-Chloro-2-Isothiazol-3-one	< 1%
	2-Methyl-2H-Isothiazol-3-O Chlorinedioxide	< 1%
	Sodiumchlorite 100%	< 1%
Virex II 256	Didecyl dimethyl ammonium chloride	8.704%
	n-Alkyl dimethyl benzyl ammonium chloride	8.19%

NOTE

These disinfectants are only compatible with the probe materials, but the efficacy of realizing the appropriate level of disinfection has not been validated by Mindray.

This page intentionally left blank.

6 Cleaning and Sterilizing the Needle-guided Bracket

NOTE:

Disposable components are packaged sterile and are single-use only. Do not use if integrity of packaging is violated or if expiration date has passed. Please use the disposable components compliant with the relevant local regulations.

CAUTION

- **Needle-guided brackets whose name starts with NGB are reusable, and need thorough cleaning and sterilization before and after each biopsy.**
- **Follow local regulations when selecting and using the disinfectant.**
- **Repeated sterilization may degrade the safety and performance of the needle-guided bracket. Before use, please check whether the needle-guided bracket has defects such as deformation and rusting. If such defects exist, the bracket has reached the end of its service life. In this case, stop using it and contact the Mindray service department.**
- **It is recommended to use immersion sterilization for plastic needle-guided brackets and high-pressure steam sterilization for metal needle-guided brackets.**
- **For detailed operations about the cleaning solvent, sterilant and high-temperature steam sterilizer, see the respective operator's manuals provided by the cleaning solvent, sterilant and high-temperature steam sterilizer manufacturer.**

6.1 Cleaning

Perform the following procedure:

1. Wear a pair of gloves to prevent infection.
2. After use, immerse the needle-guided bracket in clean water immediately to prevent dirt from drying. Wipe the entire surface of the needle-guided bracket by using a piece of disposable lint-free soft cloth to remove coarse dirt.
3. Prepare a cleaning solvent (enzymatic or neutral pH detergent, e.g., liquinox, MetriZyme) by using clean water in accordance with the operator's manual provided by the cleaner manufacturer.
4. Detach all the detachable parts of the needle-guided bracket and immerse the needle-guided bracket and all its parts fully in the cleaning solvent for at least 1 minute or a period specified by the cleaner manufacturer.

5. Immerse the needle-guided bracket and all its parts fully in the cleaning solvent. Wipe and wash the surface and connecting parts of the needle-guided bracket gently by using a soft brush until no dirt is visible. Place the needle-guided bracket inside an ultrasonic cleaner and perform ultrasonic cleaning for 3–5 minutes.
6. Rinse the needle-guided bracket thoroughly by using a large amount of clean water (about 7.5 L/2 gallons) at room temperature for about 1 minute to remove the residual dirt and cleaning solvent.
7. Wipe away the water on the needle-guided bracket by using a piece of disposable lint-free soft cloth.
8. Inspect the needle-guided bracket. If visible dirt still exists, repeat the preceding steps to wash the bracket until it is all clean.

6.2 Sterilization

6.2.1 Sterilization with a Sterilant

Perform the following procedure:

1. Wear a pair of gloves to prevent infection.
2. Clean thoroughly in accordance with the cleaning procedure before sterilization.
3. Prepare a sterilant by using sterile distilled or softened water when necessary.

Table 6-1 Recommended sterilization solution

Chemical name	Trade name	Procedures
Glutaraldehyde (2.4%)	Cidex Activated Dialdehyde Solution (applicable for FDA region only)	Refer to the instructions provided by the sterilant manufacturer for details.
22% Hydrogen Peroxide 4.5% Peroxyacetic Acid	Minnicare liquid disinfectant (applicable for Canada only)	
Glutaraldehyde (2.6%)	MetriCide	

4. Immerse the needle-guided bracket fully in the sterilant and shake the bracket appropriately to remove any bubbles on the surface. Use a syringe to draw an appropriate amount of sterilant and inject the sterilant into the hole to remove the bubbles inside the hole if necessary.

For details about the immersion duration, see the operator's manual provided by the sterilant manufacturer.

5. After sterilization, wash the needle-guided bracket thoroughly by using a large amount of sterile distilled water (about 7.5 L/2 gallons) at room temperature for about 1 minute to remove the residual sterilant.
6. Dry the needle-guided bracket with a piece of sterile disposable lint-free soft cloth.
7. Store the needle-guided bracket in a cool, clean and dry environment.

6.2.2 High-Pressure Steam Sterilization

Perform the following procedure:

1. Wear a pair of gloves to prevent infection.
2. Clean thoroughly in accordance with the cleaning procedure before sterilization.

3. Package the needle-guided bracket in accordance with the sterilization requirements of surgical instruments.
4. Place the packaged needle-guided bracket inside a high-temperature steam sterilizer and perform sterilization. The sterilization parameters are 121 °C and 30 minutes for a gravity displacement steam sterilizer and are 132 °C and 4 minutes for a dynamic-air-removal steam sterilizer.
5. Take out the sterilization package after sterilization and dry it in an oven at 60 °C for 20 minutes to 30 minutes.

Keep the sterilization package together with other sterilized surgical instruments in a sterile item storage area.

This page intentionally left blank.

7 Cleaning and Disinfecting the Main Unit

7.1 Cleaning

WARNING

Before cleaning the main unit, be sure to turn off the power and disconnect the power cord from the outlet. If you clean the system while the power is “On”, it may result in electric shock.

Especially, ME series/TE series/Hepatus 7 series/Hepatus 6 series/Hepatus 5 series ultrasound system have passed puncture test and leakage current test, and thus can be cleaned in power-on status.

CAUTION



Do not spill water or other liquid into the system while you perform the cleaning. Otherwise it may result in malfunction or electric shock.

NOTE:

- Do not use chemical solvents, or acid or alkaline solution to clean the main unit.
- Do not use hydrocarbon glass cleaner or cleaner for OA (Office Automation) equipment to clean the monitor. These substances may cause deterioration of the monitor.
- Use a soft brush to brush away dust attached to all visible sockets or interfaces (such as probe sockets, sockets or interfaces in the I/O panel and power supply panel). Do not use a cloth moistened with water.
- Keyboard on the control panel should be cleaned periodically, otherwise, keys may be blocked by dirt and buzzer dings, and thus keys don't work.

7.1.1 Cleaning the Display

Perform the following steps to clean the display of ultrasound system (including monitor and touch screen).

1. Power off and unplug the system.
 - For TE series/Hepatus 7 series/Hepatus 6 series/Hepatus 5 series ultrasound system, you can clean the monitor in power-on status: tap  in the top-right corner of the screen and select  to lock the system for 10 seconds while the power is “On”.

- For ME series ultrasound system, you can clean the touch screen in power-on status: tap > bar in the left side of the touch screen to enter exam main menu, and select  to lock the system for 10 seconds while the power is “On”.
2. Wear medical gloves.
 3. Clean the display surface with a soft dry cloth. Remaining stains should be wiped away using a cloth with a little neutral detergent or clean water and then leave the display to air dry.

Do not dry the display by heating.

For disinfection information, see "7.2 Disinfection".

7.1.2 Cleaning the Control Panel

Perform the following steps to clean the control panel.

1. Power off and unplug the system.
For ME series ultrasound system, you can clean the control panel in power-on status: tap > bar in the left side of the touch screen to enter exam main menu, and select  to lock the system for 10 seconds while the power is “On”.
2. Wear medical gloves.
3. Wipe the surface of control panel (including keys, buttons and sliders) with dry and soft cloth. Or wipe off difficult-to-remove soils by using soft cloth dampened with a bit of mild soapy water, and wipe the surface with dry and soft cloth or allow it to air dry. If it is difficult to clean the operation panel, remove the encoder caps, and then clean it with mild soapy water.



4. Allow the control panel to air dry.

Do not dry the control panel by heating.

For disinfection information, see "7.2 Disinfection".

7.1.3 Cleaning the Cover

Perform the following steps to clean the cover.

1. Power off and unplug the system.
TE series/Hepatus series ultrasound system has passed puncture test and leakage current test, and thus can be cleaned in power-on status. In power-on status, tap  in the top-right corner of the screen and select  to lock the system for 10 seconds.
2. Wear medical gloves.
3. Use a soft dry cloth to clean the system’s cover. If the system is dirty, moisten the soft cloth with neutral soapy water to wipe away any stains.

4. Allow the cover to air dry.

Do not dry the cover by heating.

For disinfection information, see "7.2 Disinfection".

7.1.4 Cleaning Other Parts

For details on cleaning other parts of the main unit, such as trackball and dust-proof cover, refer to the basic volume of ultrasound system operator’s manual.

7.2 Disinfection

WARNING

- Before disinfecting the main unit, be sure to turn off the power and disconnect the power cord from the outlet. Disinfecting the main unit while the power is “On” may result in electric shock.

Especially, ME series ultrasound system equipped with trackpad, TE series, Hepatus 7 series, Hepatus 6 series, and Hepatus 5 series ultrasound system have passed puncture test and leakage current test, and thus can be disinfected in power-on status.

- Use only Mindray approved disinfectants and methods listed in this section to disinfect the main unit. Warranty does not cover damage caused by unapproved substances or methods.
- Do not mix disinfectants, as hazardous gases may result.
- We make no claims regarding the efficacy of the listed chemicals or methods as a means for controlling infection. For the method to control infection, consult your hospital’s infection control officer or epidemiologist.

CAUTION

- Never immerse any part of the main unit in liquids or allow liquid to enter the interior.
- Any contact of disinfectants with connectors or metal parts may cause corrosion.
- Do not pour or spray any liquid directly on the main unit or permit fluid to seep into connections or openings. If you spill liquid on the main unit, disconnect the power supply, dry the main unit, and contact your service personnel.
- Never use abrasive materials (such as steel wool or silver polish), or erosive cleaners (such as acetone or acetone-based cleaners).
- Dilute and use the disinfectants according to the disinfectant manufacturer’s instructions.
- Check the system after cleaning and disinfection. If there is any sign of damage, remove it from use.

NOTE:

- Disinfectants listed in this section are used for disinfecting the housing of the main unit and the monitor only, not for disinfecting the probes.
- Wear medical gloves to prevent transfer of soils and infection.
- Follow local regulations when selecting and using the disinfectant.

Different types of ultrasound systems (such as cart-based, hand-carried and touch screen) vary in materials of cover, display and control panel, and thus their resistance to disinfectants are different. Therefore, different ultrasound systems are compatible with different disinfectants.

Currently, except for the product listed in 7.2.1, other products can not be disinfected.

7.2.1 Identifying the Areas That can be Disinfected

TE7/TE5 Series

Hepatus 7/Hepatus 6/Hepatus 5 Series

The main unit cover and monitor of the ultrasound system can be disinfected. For details, see the areas highlighted in gray color in Figure 7-1.

Do not disinfect handle, or any visible sockets or interfaces (such as probe sockets, ventilation holes, dust-proof cover, loudspeaker, sockets or interfaces in the I/O panel and power supply panel).

For detailed compatible disinfectants of this series, see "Table 7-2 Compatible Disinfectants of Portable Ultrasound System".

Figure 7-1 Areas that can be disinfected (highlighted in gray color)

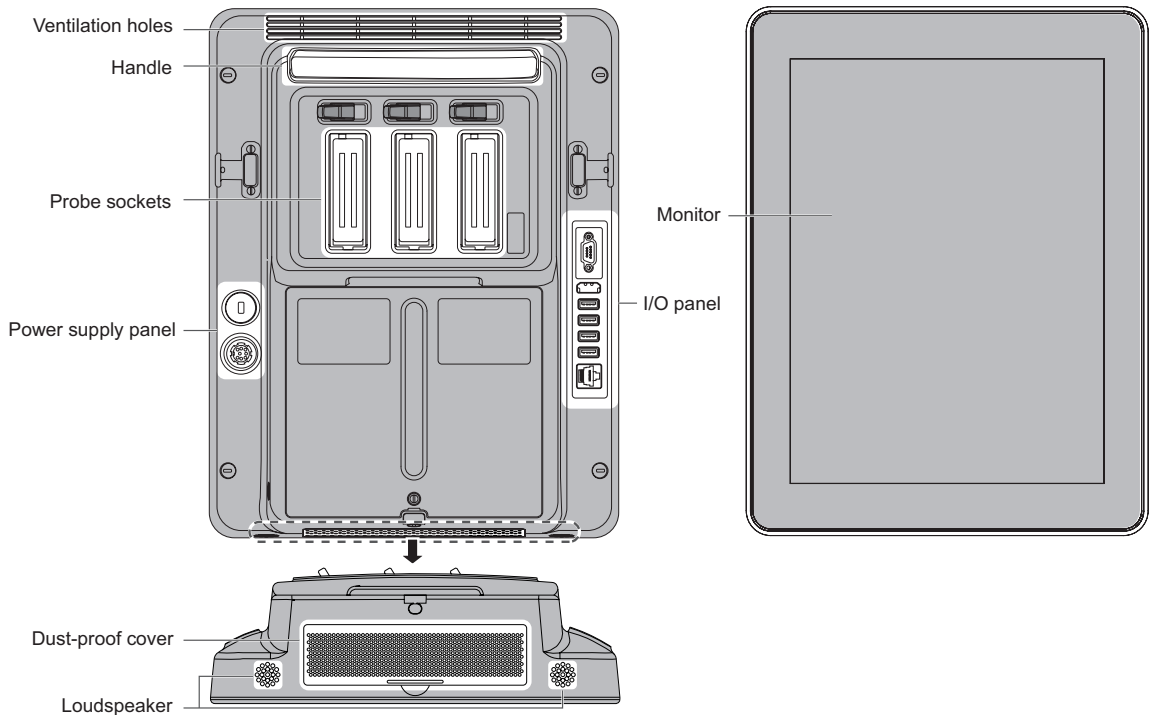

TE9 Series

The main unit cover and monitor of the ultrasound system can be disinfected. For details, see the areas highlighted in gray color in Figure 7-2.

Do not disinfect handle, or any visible sockets or interfaces (such as probe sockets, ventilation holes, dust-proof cover, loudspeaker, sockets or interfaces in the I/O panel and power supply panel).

For detailed compatible disinfectants of this series, see "Table 7-2 Compatible Disinfectants of Portable Ultrasound System".

Figure 7-2 Areas that can be disinfected (highlighted in gray color)

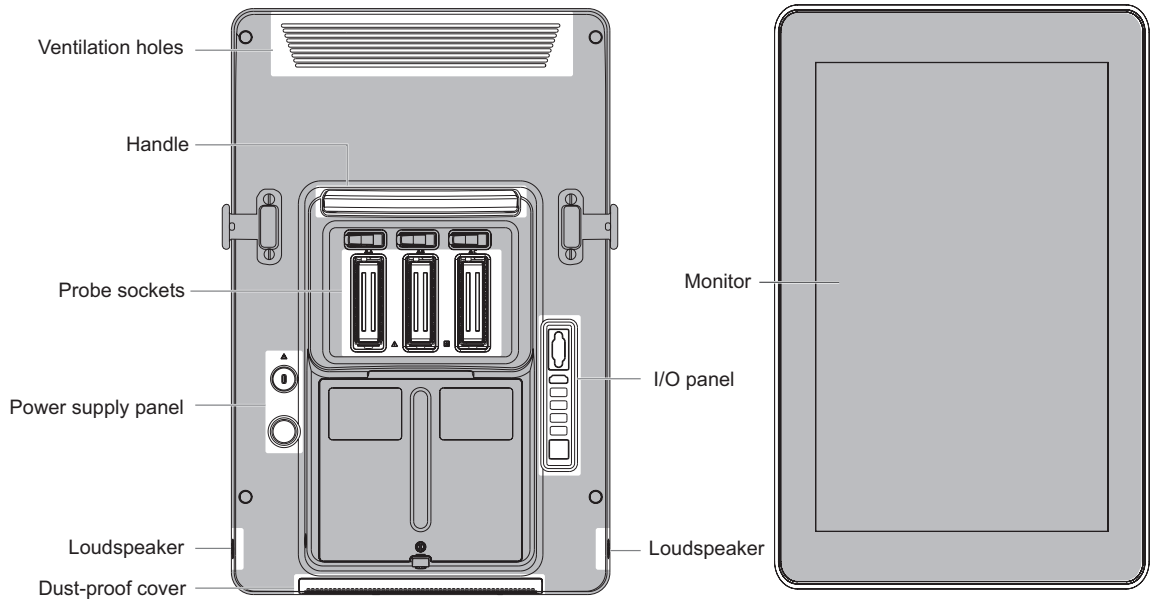

UMT-400/UMT-400Plus Trolley

Only the trolley handle can be disinfected. Other parts (including the height adjusting lever) cannot be disinfected. The diagram of the UMT-400 is taken as an example.

For detailed compatible disinfectants of this series, see "Table 7-2 Compatible Disinfectants of Portable Ultrasound System".

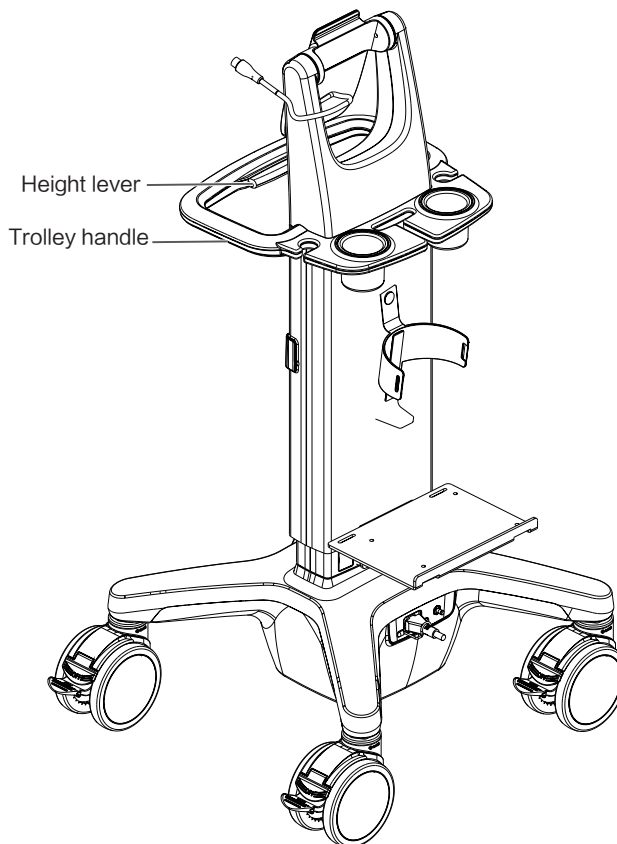

TEX Series

The front handle, cover above the front handle, ePanel, and the monitor of the ultrasound system can be disinfected. For details, see Figure 7-3.

Do not disinfect trolley back handle, any visible sockets or interfaces (such as probe sockets, ventilation holes, loudspeaker, I/O interface and power supply panel).

For detailed compatible disinfectants of this series, see "Table 7-2 Compatible Disinfectants of Portable Ultrasound System".

Figure 7-3 Areas that can be disinfected (highlighted in gray color)

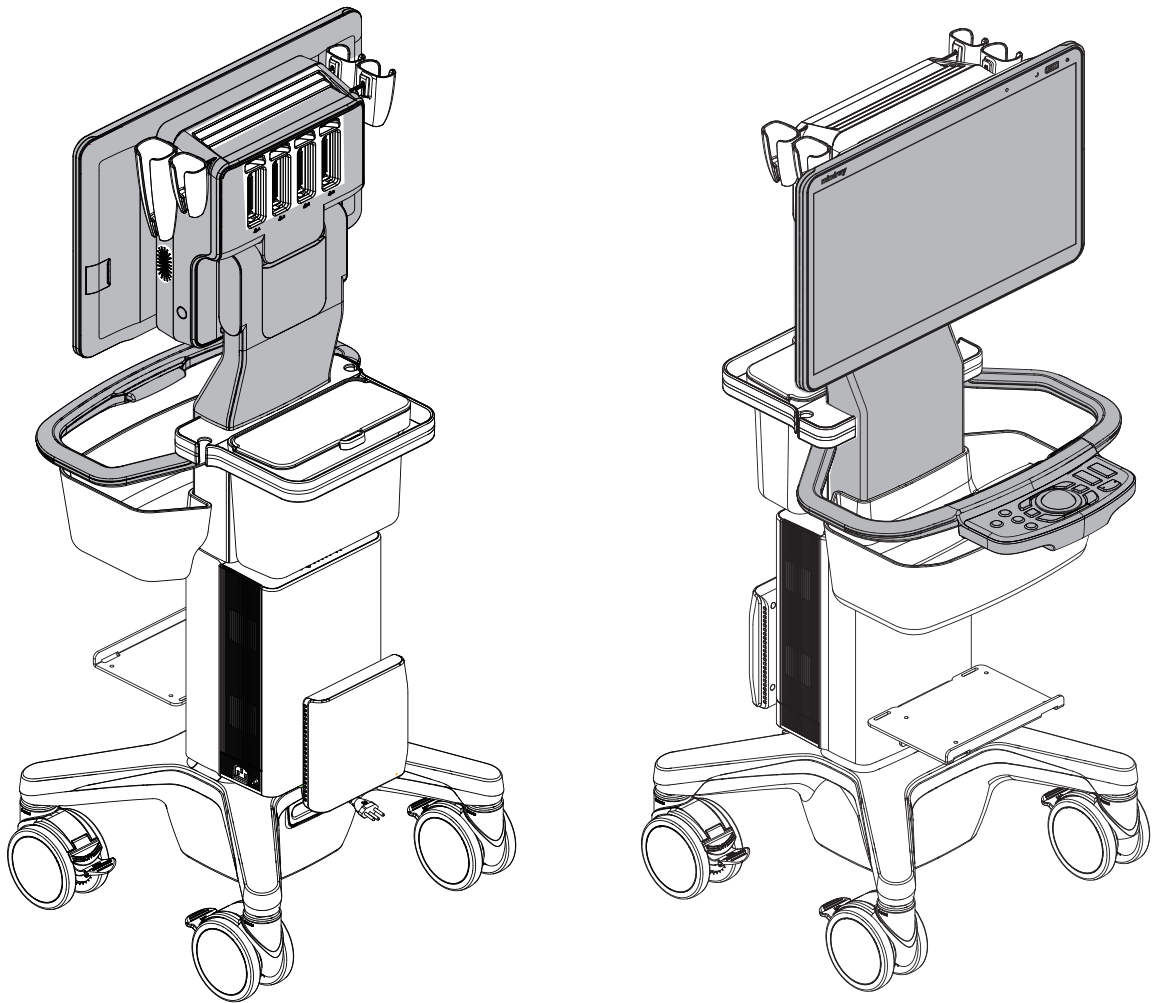

ME7/ME8 Series (with trackpad)

The control panel, touch screen, and other parts can be disinfected. For details, see Figure 7-4.

Do not disinfect the top cover, bottom cover, side panels around the main unit, manufacturer logo, any visible sockets or interfaces (such as probe socket, ventilation holes, dust-proof cover, loudspeaker, sockets or interfaces in the I/O panel and power supply panel).

For detailed compatible disinfectants of this series, see "Table 7-2 Compatible Disinfectants of Portable Ultrasound System".

Figure 7-4 Areas that can be disinfected (highlighted in gray color)

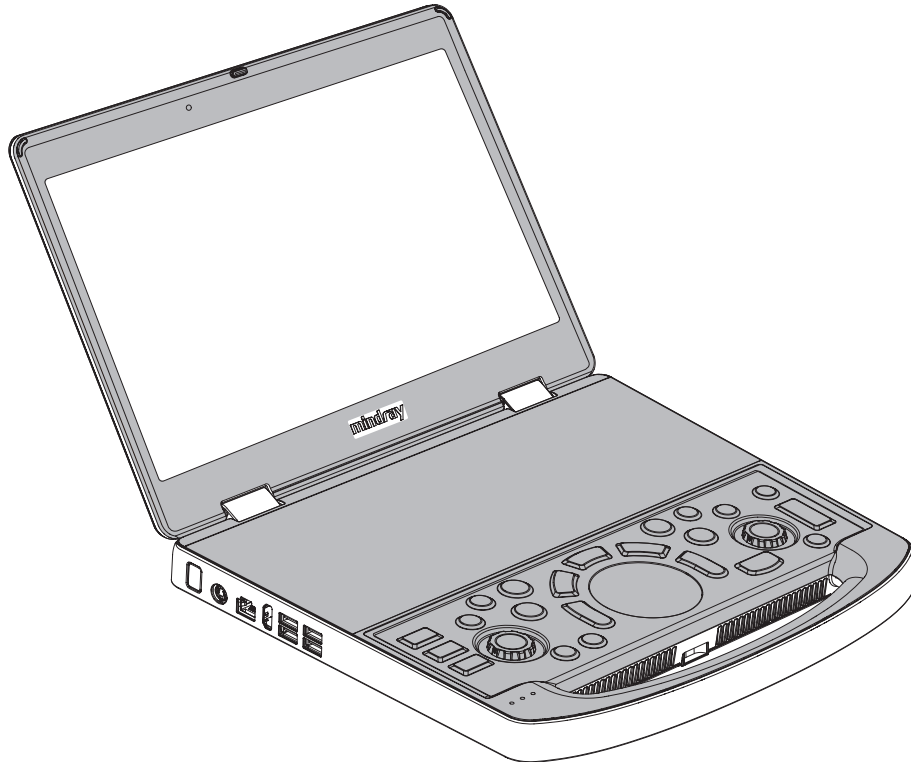

MT3 Trolley

The trolley handle (except height level), probe holder, storage box and power adapter bracket can be disinfected. For details, see Figure 7-5.

For detailed compatible disinfectants of this series, see "Table 7-2 Compatible Disinfectants of Portable Ultrasound System".

Figure 7-5 Areas that can be disinfected (highlighted in gray color)

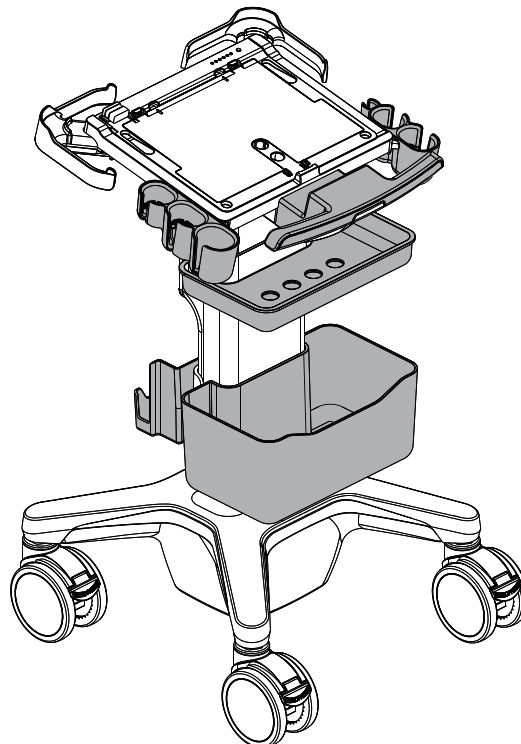

MX6/MX5/MX3 Series (with touchpad)

The control panel, handle, monitor, and the back cover of the monitor can be disinfected. For details, see Figure 7-6.

Do not disinfect the bottom cover, side panels around the main unit, any visible sockets or interfaces (such as probe socket, ventilation holes, dust-proof cover, loudspeaker, sockets or interfaces in the I/O panel and power supply panel).

For detailed compatible disinfectants of this series, see "Table 7-2 Compatible Disinfectants of Portable Ultrasound System".

Figure 7-6 Areas that can be disinfected (highlighted in gray color)

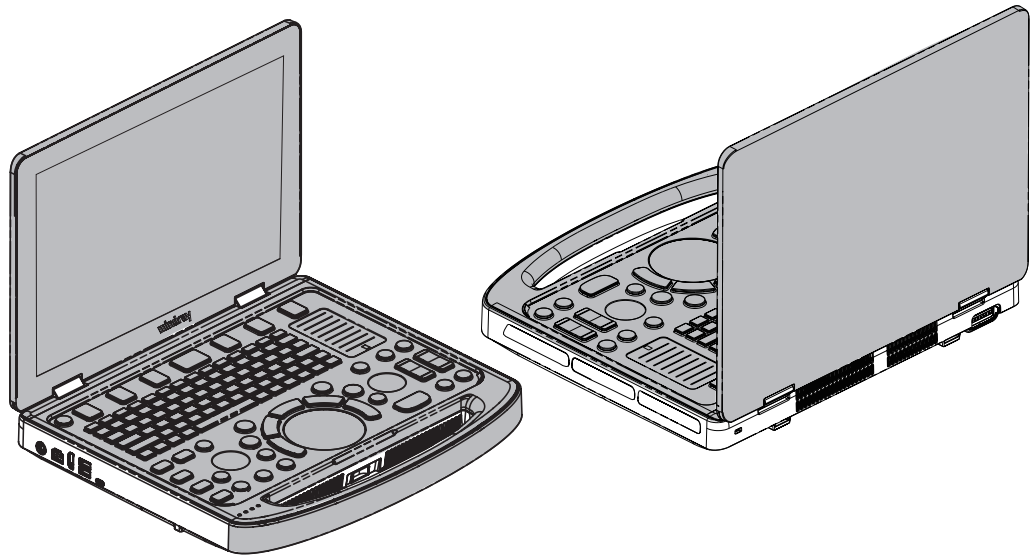

AirSight (used for running TE Air)

The monitor, border and cover, except for loudspeaker and USB Type-C port, can be disinfected. For details, see Figure 7-7.

For detailed compatible disinfectants of this series, see "Table 7-2 Compatible Disinfectants of Portable Ultrasound System".

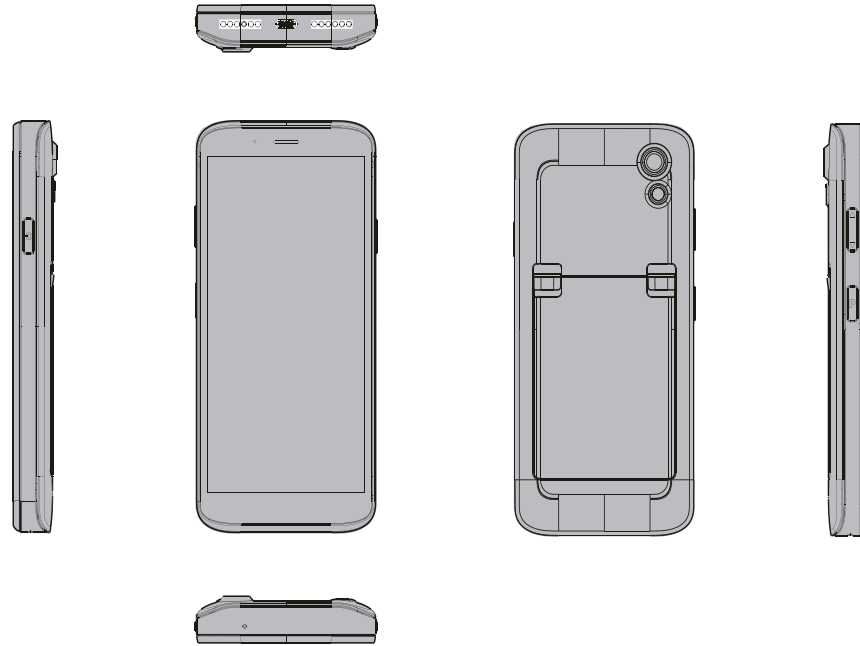
Figure 7-7 Areas that can be disinfected (highlighted in gray color)

Resona A10/Resona A20 Series

The control panel and above parts, including the control panel handle, trackball, small keyboard, cable hook, intracavity probe holder, gel heater, probe holder, main screen border, and main screen back cover, can be disinfected. For details, see Figure 7-8.

Disinfect the trackball after removing it from the control panel. After disinfecting the trackball, clean it with clean water to remove the residue disinfectants.

Areas that cannot be disinfected:

- Visible interfaces or sockets (for example, USB ports)
- Main screen, touch screen
- Trackball placing area of the control panel (the hole after removing the trackball)

For detailed compatible disinfectants of this series, see "Table 7-3 Compatible Disinfectants of Cart-based Ultrasound System".

Figure 7-8 Areas that can be disinfected (highlighted in gray color)

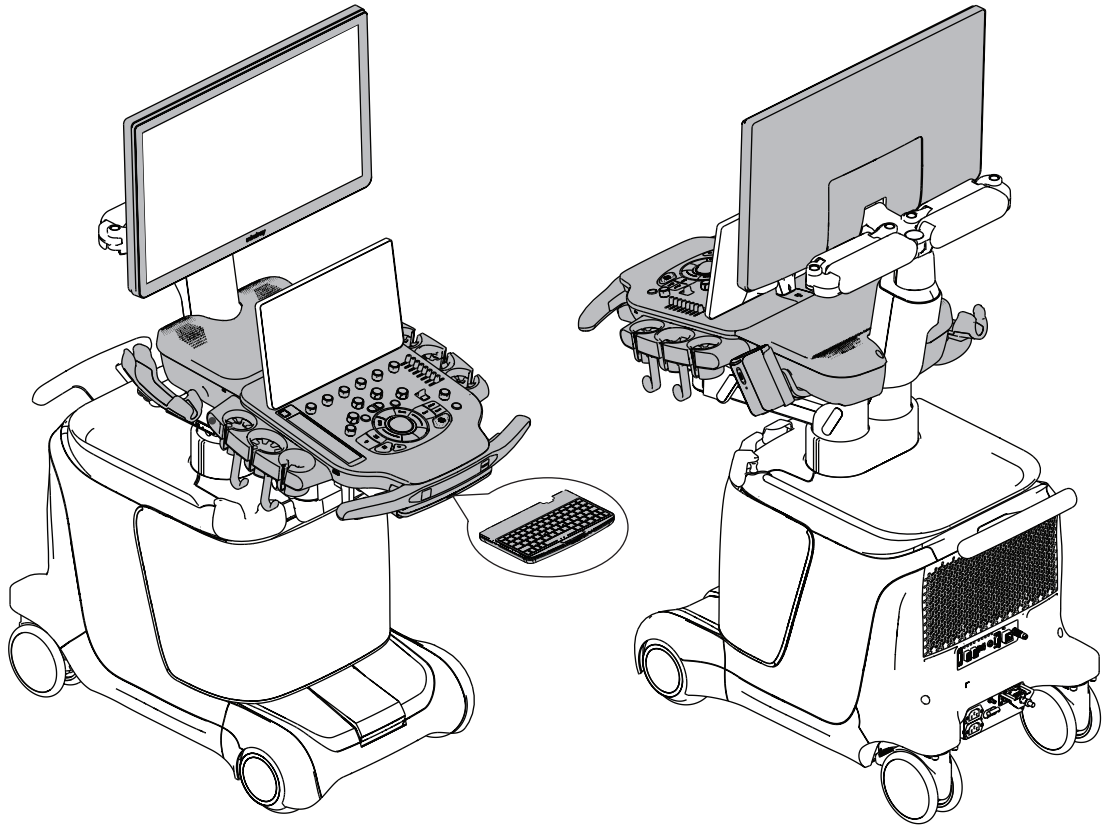

Nuewa A10/Nuewa A20 Series

The control panel and above parts, including the control panel handle, trackball, small keyboard or X-Pad (subject to product configuration), cable hook, intracavity probe holder, gel heater, probe holder, main screen border, and main screen back cover, can be disinfected. For details, see Figure 7-9 or Figure 7-10.

Disinfect the trackball after removing it from the control panel. After disinfecting the trackball, clean it with clean water to remove the residue disinfectants.

Areas that cannot be disinfected:

- Visible interfaces or sockets (for example, USB ports)
- Main screen, supporting arm of the main screen, touch screen
- Trackball placing area of the control panel (the hole after removing the trackball)

For detailed compatible disinfectants of this series, see "Table 7-3 Compatible Disinfectants of Cart-based Ultrasound System".

Figure 7-9 Areas that can be disinfected for the ultrasound system without electrically assisted moving function (highlighted in gray color)

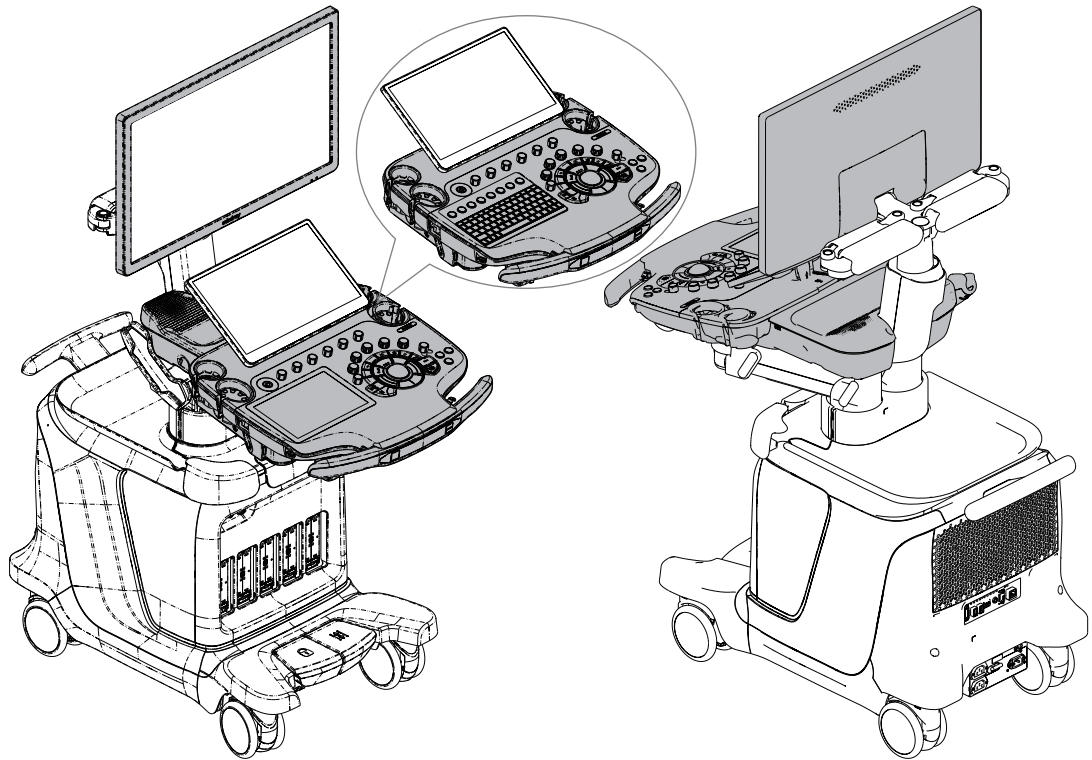
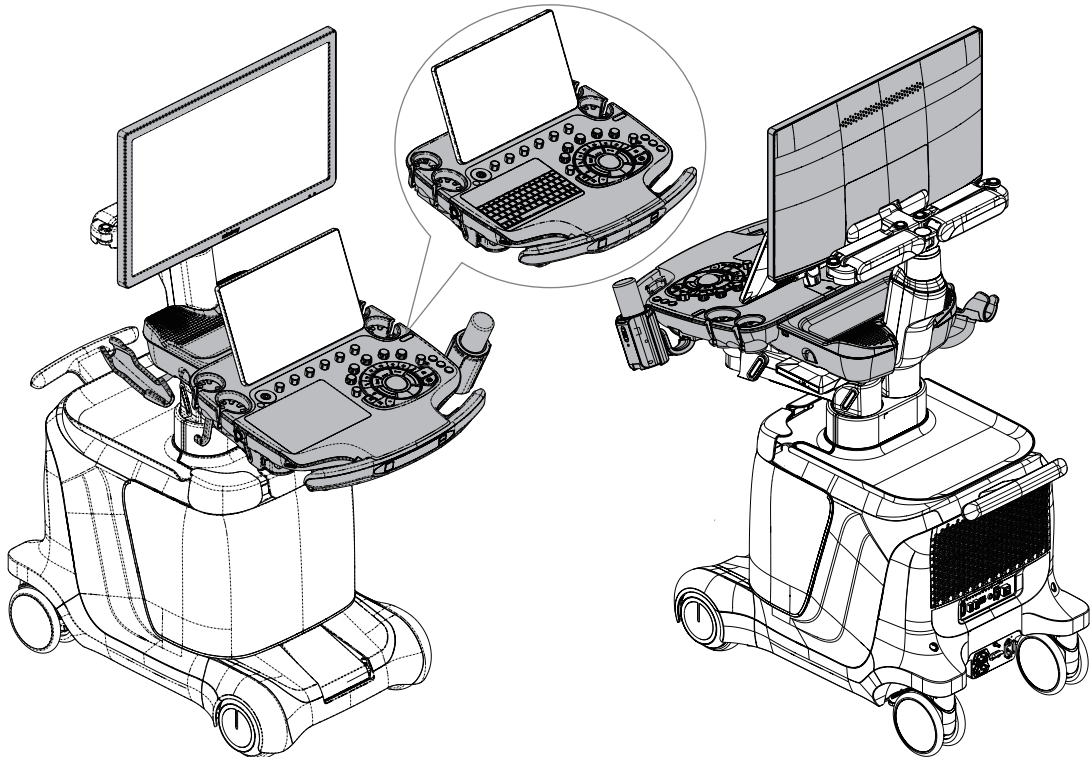

Figure 7-10 Areas that can be disinfected for the ultrasound system with electrically assisted moving function (highlighted in gray color)



Recho R9 Series

The control panel and above parts, including the control panel handle, trackball, small keyboard, cable hook, intracavity probe holder, gel heater, probe holder, minor panel storage box, main screen border, and main screen back cover, can be disinfected. For details, see Figure 7-11.

Disinfect the trackball after removing it from the control panel. After disinfecting the trackball, clean it with clean water to remove the residue disinfectants.

Areas that cannot be disinfected:

- Visible interfaces or sockets (for example, USB ports)
- Main screen, touch screen
- Trackball placing area of the control panel (the hole after removing the trackball)
- Monitor supporting arm and minor panel upper cover

For detailed compatible disinfectants of this series, see "Table 7-3 Compatible Disinfectants of Cart-based Ultrasound System".

Figure 7-11 Areas that can be disinfected (highlighted in gray color)

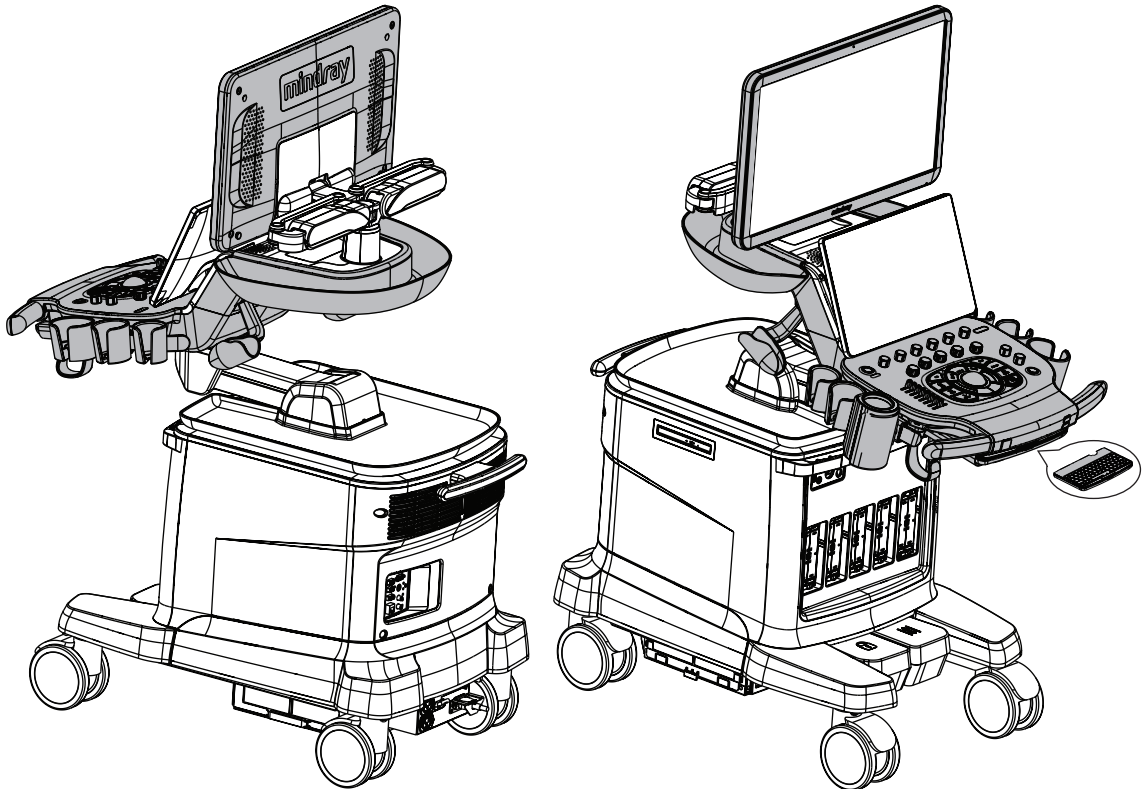

Resona R9/Nuewa R9/Resona R7/Nuewa R7/Resona 7 Series

The control panel and related parts, including the touch screen, cable hook, intracavity probe holder, gel heater, and probe holder, can be disinfected. For details, see Figure 7-12.

Do not disinfect the visible connectors or sockets (for example, USB ports).

For detailed compatible disinfectants of this series, see "Table 7-3 Compatible Disinfectants of Cart-based Ultrasound System".

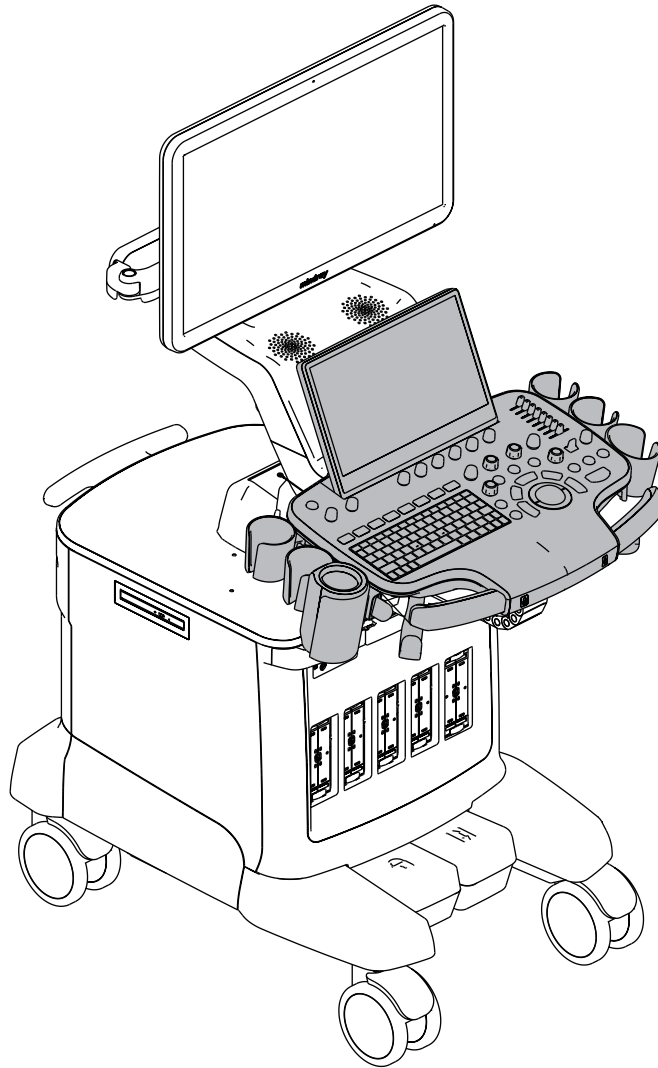
Figure 7-12 Areas that can be disinfected (highlighted in gray color)**Resona I9/Nuewa I9/Imagyn I9 Series (Method 1)****Hepatus 10/Hepatus 9/Hepatus 8 Series (Method 1)**

The control panel and above parts, including the main screen back cover, main screen border, touch screen, the tray below the touch screen, control panel, control panel base, control panel handle, trackball, probe holder, small keyboard, intracavity probe holder, gel heater holder, and gel heater, can be disinfected. The main unit, including the main unit housing, rear handle, storage basket, and storage basket bracket, can be disinfected. For details, see Figure 7-13.

Disinfect the trackball after removing it from the control panel. After disinfecting the trackball, clean it with clean water to remove the residue disinfectants.

Areas that cannot be disinfected:

- Visible interfaces or sockets (for example, USB ports)
- Cooling vent and speaker
- Main screen
- Trackball placing area of the control panel (the hole after removing the trackball)
- Monitor supporting arm and control panel supporting arm

- Cable hooks
- System base and casters

For detailed compatible disinfectants of this series, see "Table 7-3 Compatible Disinfectants of Cart-based Ultrasound System".

Figure 7-13 Areas that can be disinfected (highlighted in gray color)

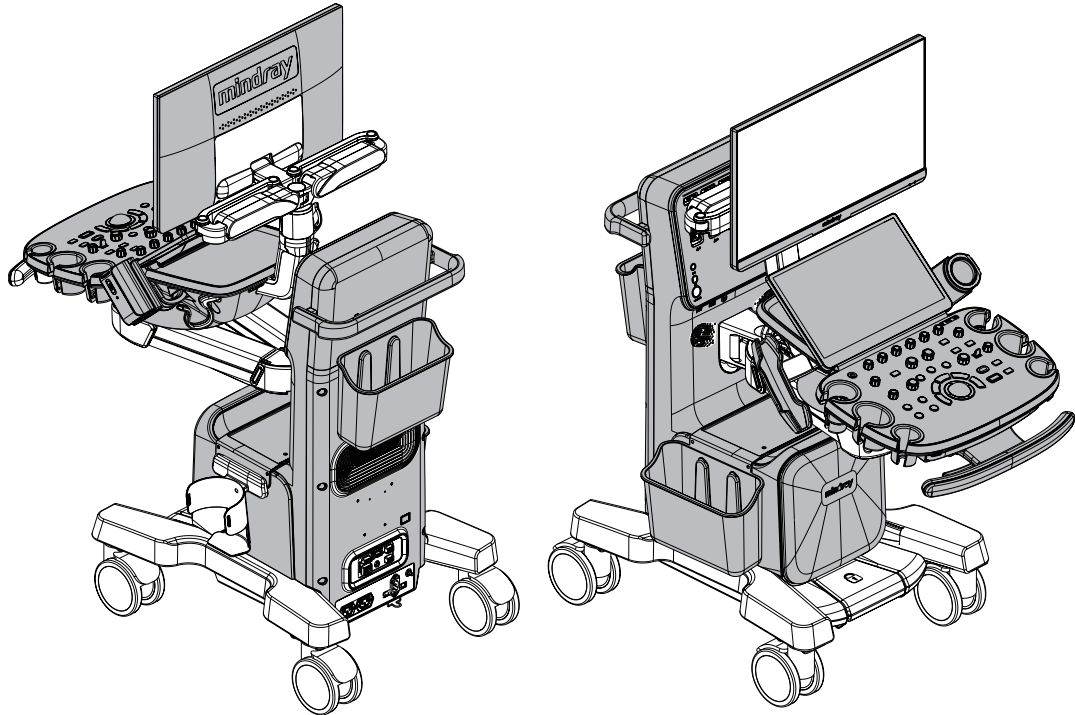

Resona I9/Nuewa I9/Imagyn I9 Series (Method 2)

Hepatus 10/Hepatus 9/Hepatus 8 Series (Method 2)

The control panel and above parts, including the main screen back cover, main screen border, touch screen, the tray below the touch screen, control panel, control panel base, control panel handle, trackball, probe holder, small keyboard, intracavity probe holder, gel heater holder, and gel heater, can be disinfected. For details, see Figure 7-14.

Disinfect the trackball after removing it from the control panel. After disinfecting the trackball, clean it with clean water to remove the residue disinfectants.

Areas that cannot be disinfected:

- Visible interfaces (for example, USB ports)
- Main screen
- Trackball placing area of the control panel (the hole after removing the trackball)
- Monitor supporting arm
- Cable hooks

For detailed compatible disinfectants of this series, see "Table 7-3 Compatible Disinfectants of Cart-based Ultrasound System".

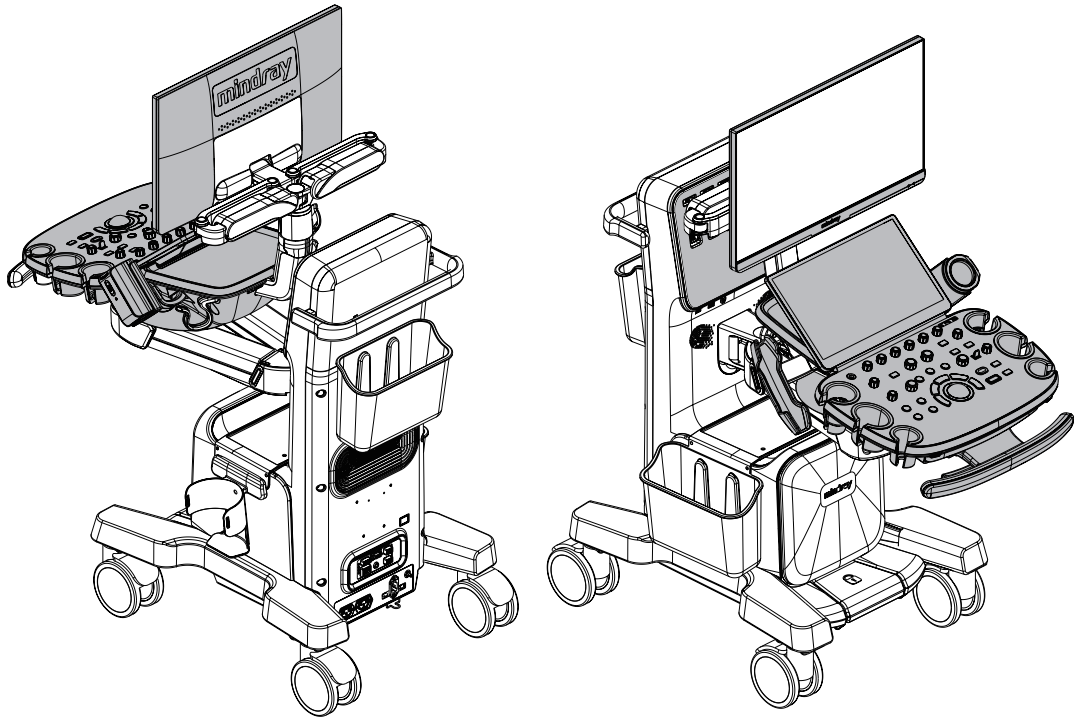
Figure 7-14 Areas that can be disinfected (highlighted in gray color)

Resona I8/Nuewa I8/Imagyn I8 Series (Method 1)

The control panel and above parts, including the main screen back cover, main screen border, touch screen, the tray below the touch screen, control panel, control panel base, control panel handle, trackball, probe holder, small keyboard, intracavity probe holder, gel heater holder, and gel heater, can be disinfected. The main unit, including the main unit housing, rear handle, storage basket, and storage basket bracket, can be disinfected. For details, see Figure 7-15.

Disinfect the trackball after removing it from the control panel. After disinfecting the trackball, clean it with clean water to remove the residue disinfectants.

Areas that cannot be disinfected:

- Visible interfaces or sockets (for example, USB ports)
- Cooling vent and speaker
- Main screen
- Trackball placing area of the control panel (the hole after removing the trackball)
- Monitor supporting arm and control panel supporting arm
- Cable hooks
- System base and casters

For detailed compatible disinfectants of this series, see "Table 7-3 Compatible Disinfectants of Cart-based Ultrasound System".

Figure 7-15 Areas that can be disinfected (highlighted in gray color)

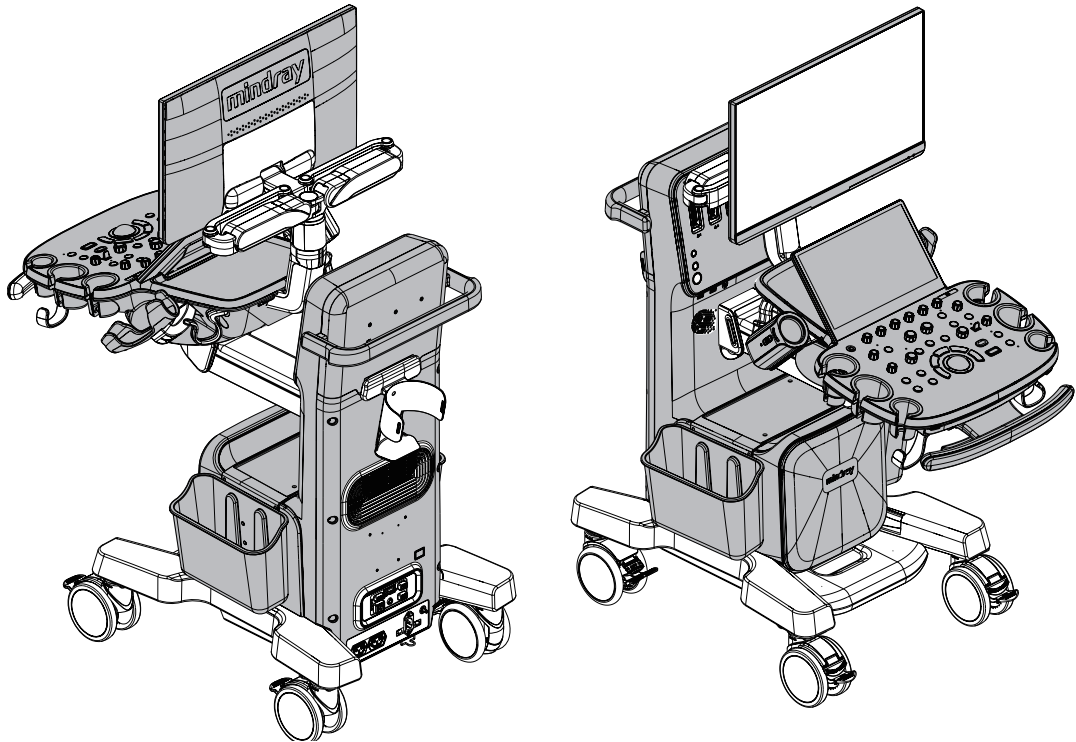

Resona I8/Nuewa I8/Imagyn I8 Series (Method 2)

The control panel and above parts, including the main screen back cover, main screen border, touch screen, the tray below the touch screen, control panel, control panel base, control panel handle, trackball, probe holder, small keyboard, intracavity probe holder, gel heater holder, and gel heater, can be disinfected. For details, see Figure 7-16.

Disinfect the trackball after removing it from the control panel. After disinfecting the trackball, clean it with clean water to remove the residue disinfectants.

Areas that cannot be disinfected:

- Visible interfaces (for example, USB ports)
- Main screen
- Trackball placing area of the control panel (the hole after removing the trackball)
- Monitor supporting arm
- Cable hooks

For detailed compatible disinfectants of this series, see "Table 7-3 Compatible Disinfectants of Cart-based Ultrasound System".

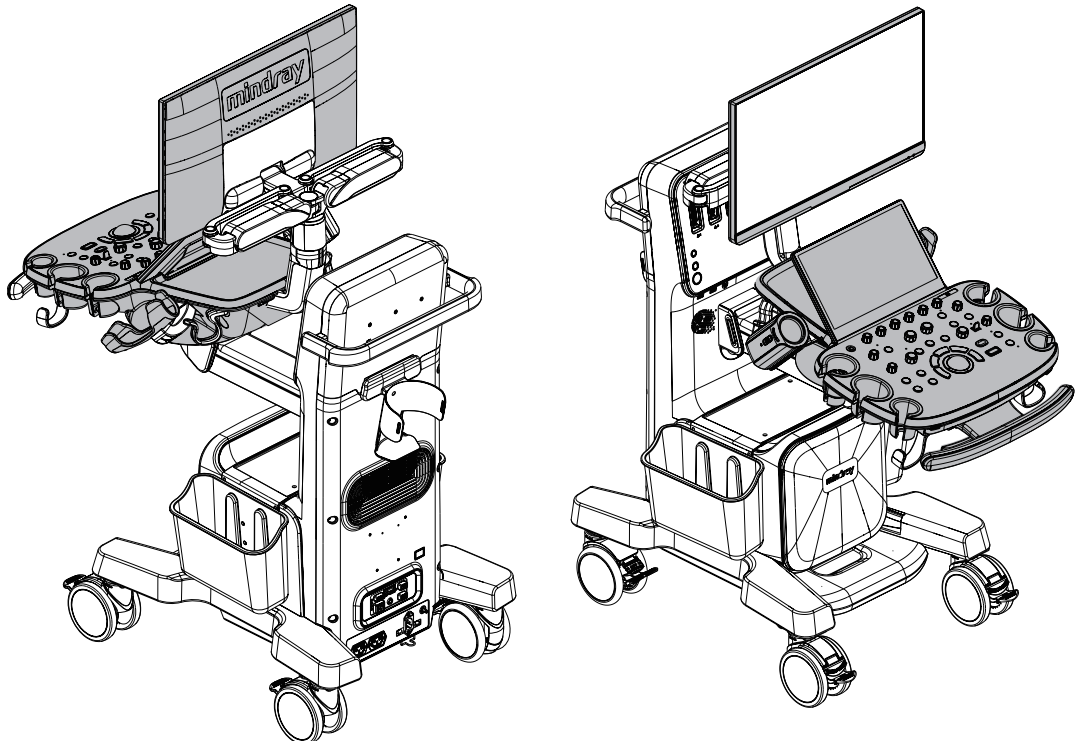
Figure 7-16 Areas that can be disinfected (highlighted in gray color)

ViewMate™ Multi

The control panel and above parts, including the main screen back cover, main screen border, touch screen, the tray below the touch screen, control panel, control panel base, control panel handle, trackball, probe holder, small keyboard, intracavity probe holder, gel heater holder, and gel heater, can be disinfected. For details, see Figure 7-17.

Disinfect the trackball after removing it from the control panel. After disinfecting the trackball, clean it with clean water to remove the residue disinfectants.

Areas that cannot be disinfected:

- Visible interfaces (for example, USB ports)
- Main screen
- Trackball placing area of the control panel (the hole after removing the trackball)
- Monitor supporting arm
- Cable hooks

For detailed compatible disinfectants of this series, see "Table 7-3 Compatible Disinfectants of Cart-based Ultrasound System".

Figure 7-17 Areas that can be disinfected (highlighted in gray color)

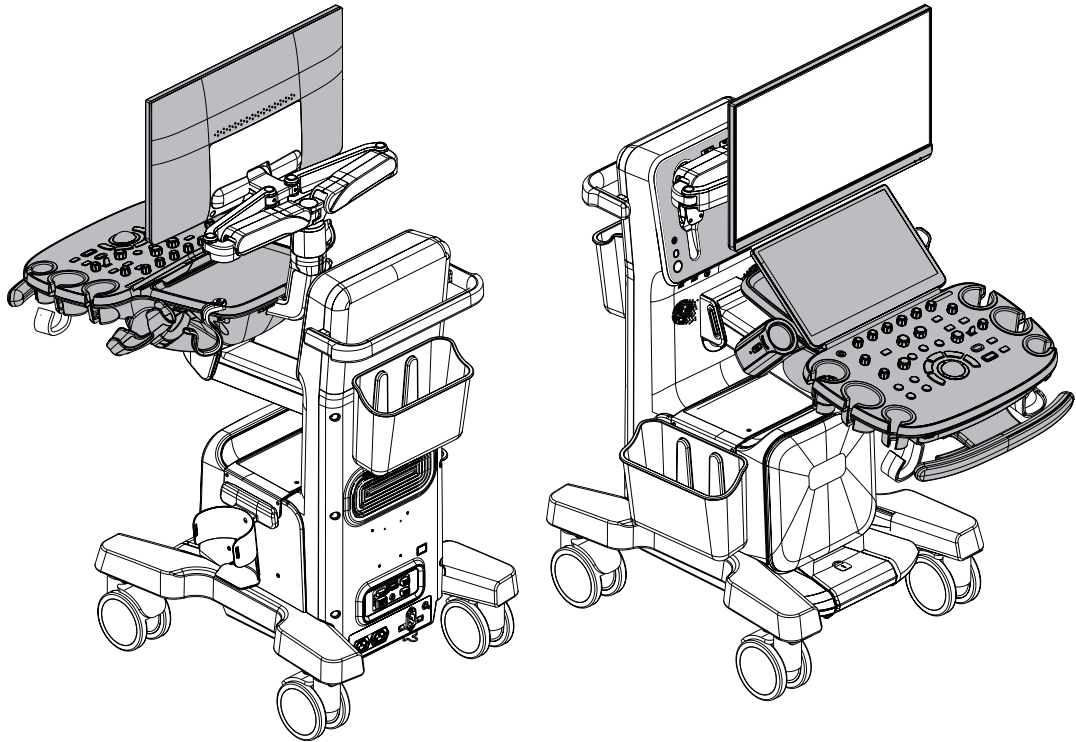

Consona N9/Consona N8/Consona N7/Consona N6/Nuewa N9/Recho N9 Series

The control panel and above parts, including the control panel, trackball, handle, probe holder, touch screen, encircling storage bin, main screen back cover, and main screen border can be disinfected. For details, see Figure 7-18, Figure 7-19, and Figure 7-20.

Disinfect the trackball after removing it from the control panel. After disinfecting the trackball, clean it with clean water to remove the residue disinfectants.

Areas that cannot be disinfected:

- Visible interfaces (for example, USB ports)
- Main screen
- Trackball placing area of the control panel (the hole after removing the trackball)
- Monitor supporting arm
- Control panel adjusting lever
- Qwerty keyboard
- Cable hooks
- intracavity probe holder
- gel heater holder and gel heater

For detailed compatible disinfectants of this series, see "Table 7-3 Compatible Disinfectants of Cart-based Ultrasound System".

Figure 7-18 Areas that can be disinfected of Consona N8/Consona N9/Nuewa N9/Recho N9 series (highlighted in gray color)

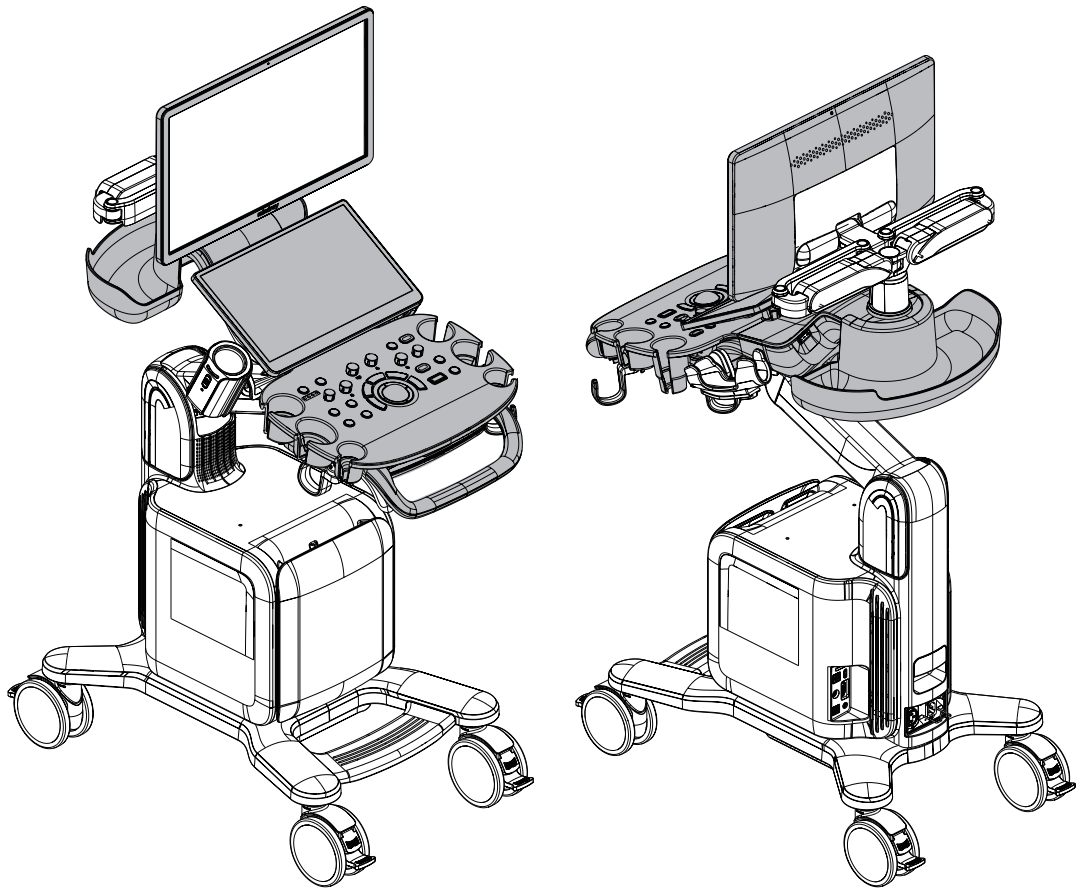

Figure 7-19 Areas that can be disinfected of Consona N7 series (highlighted in gray color)

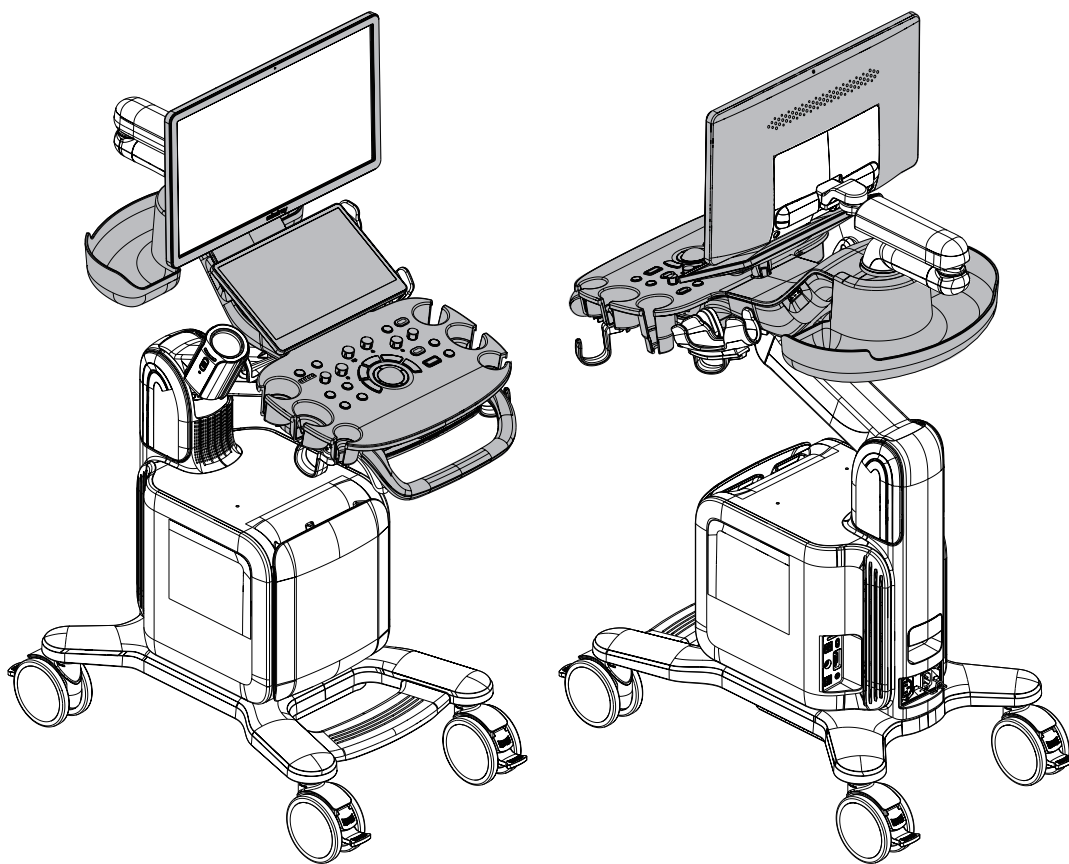
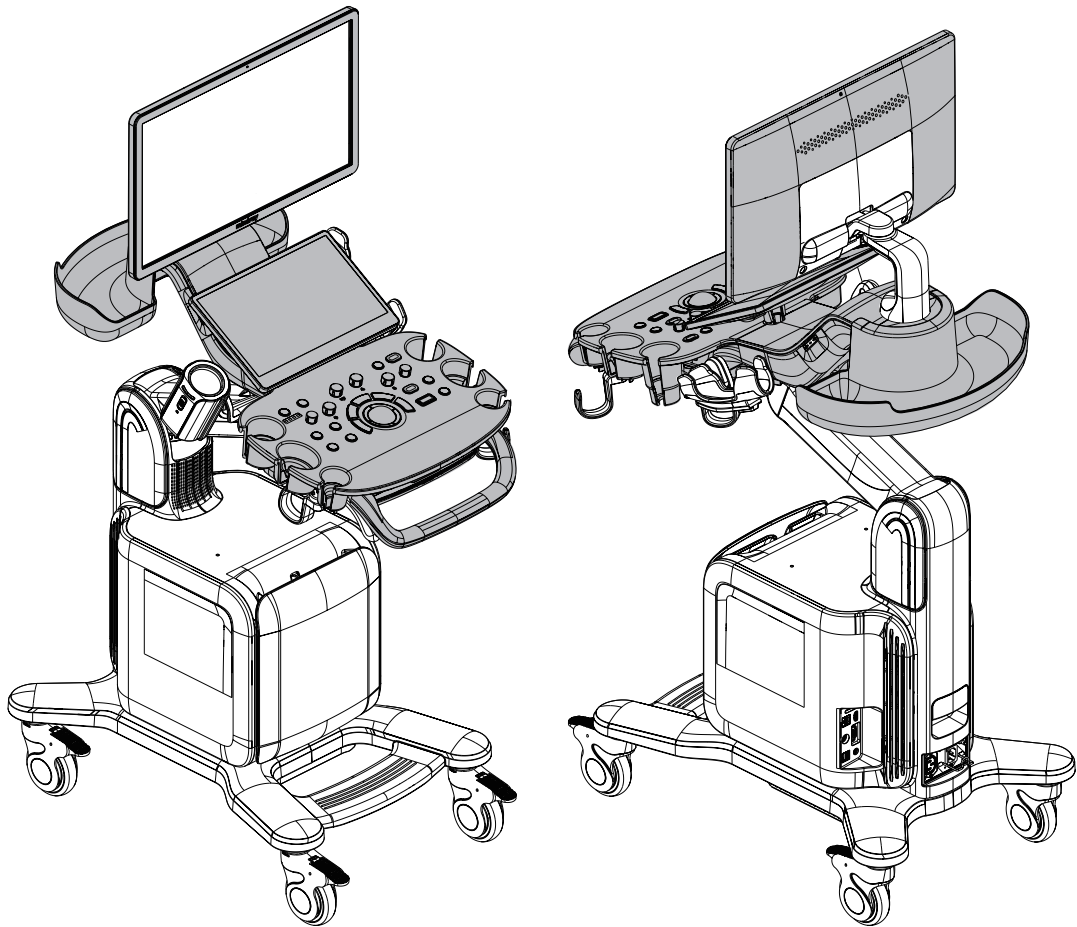

Figure 7-20 Areas that can be disinfected of Consona N6 series (highlighted in gray color)



Consona N5 Series

The control panel and above parts, including the control panel, trackball, handle, probe holder, touch screen, encircling storage bin, main screen back cover, and main screen border can be disinfected. For details, see Figure 7-21.

Disinfect the trackball after removing it from the control panel. After disinfecting the trackball, clean it with clean water to remove the residue disinfectants.

Areas that cannot be disinfected:

- Visible interfaces (for example, USB ports)
- Main screen
- Trackball placing area of the control panel (the hole after removing the trackball)
- Monitor supporting arm
- Control panel adjusting lever
- Qwerty keyboard
- Cable hooks
- Intracavity probe holder
- Gel heater holder and gel heater

For detailed compatible disinfectants of this series, see "Table 7-3 Compatible Disinfectants of Cart-based Ultrasound System".

Figure 7-21 Areas that can be disinfected (highlighted in gray color)

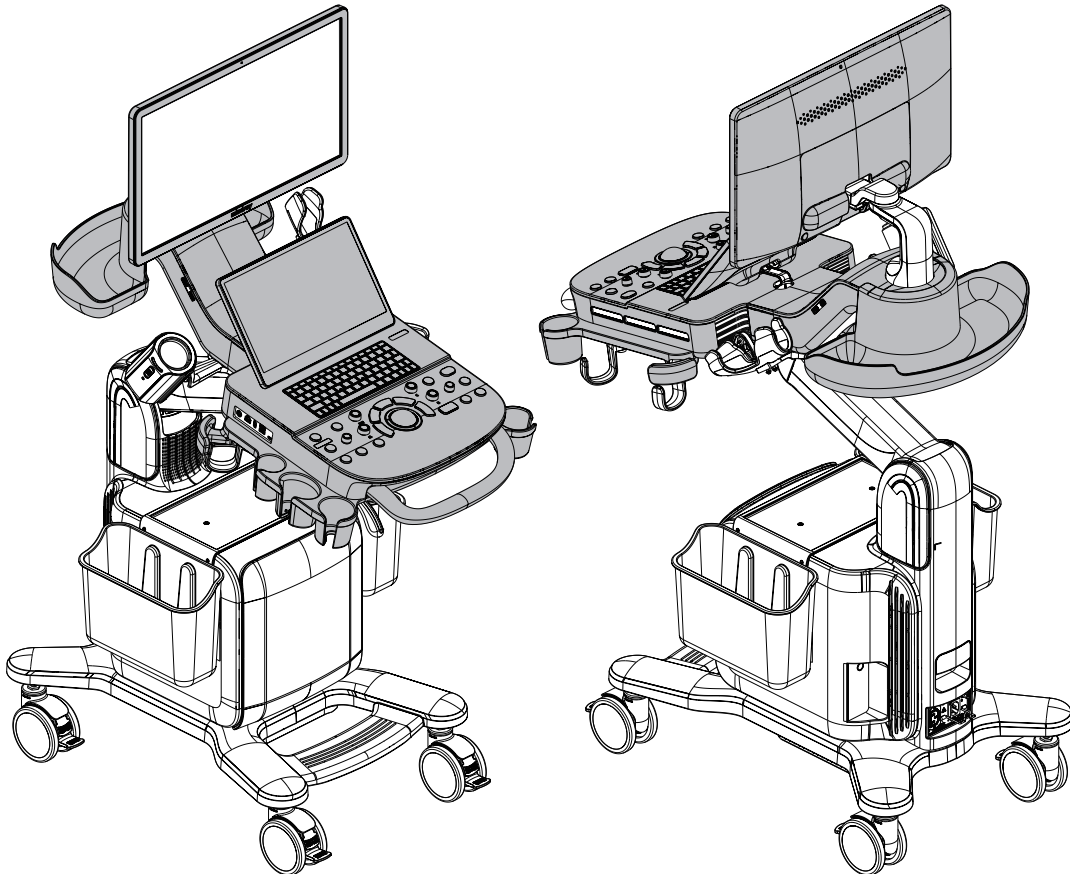

NOTE

The ultrasound system diagrams in this manual may vary due to different versions and configurations. The actual ultrasound system that you purchase shall prevail.

7.2.2 Disinfection Procedure

NOTE

Clean the main unit thoroughly in accordance with the cleaning procedure before disinfection.

Perform the following procedure:

1. Wear medical gloves to prevent infection.
2. Follow the disinfectant manufacturer's recommended contact time and method to disinfect the areas that can be disinfected with the compatible disinfectant.
3. Remove any residue with a water-moistened soft cloth on the main unit.
4. Wipe off water on the main unit using disposable lint-free soft cloth or tissue.

Do not dry the main unit by heating.

7.2.3 Compatible Disinfectants

Table 7-2 Compatible Disinfectants of Portable Ultrasound System

Trade Name	TEX Series	TE9 Series	Hepatus 7/Hepatus 6/Hepatus 5 Series	ME7/ME8 Series (with trackpad)	MX6/MX5/MX3 Series (with touchpad)	UMT-400/UMT-400Plus Trolley	MT3 Trolley	AirSight (used for running TE Air)
CLEANISEPT WIPES	√	√	√	√	√	√	√	√
mikrozid AF wipes	√		√	√	√		√	
protex ultra disinfectant wipes	√	√	√	√	√	√	√	
Sani-Cloth Plus Germicidal Disposable Cloth	√	√	√	√	√	√	√	√
SONO ULTRASOUND WIPES	√	√	√	√	√	√	√	√
clinell Universal wipes/clinell Surface Wipes	√	√	√			√		√
mikrozid sensitive wipes Jumbo	√	√	√	√	√	√	√	√
WIP'ANIOS Premium	√	√	√	√	√	√	√	√
Sani-Cloth AF3 Germicidal Disposable Wipe	√		√	√			√	
Sani-Cloth HB Germicidal Disposable Wipe								
CaviWipes	√	√		√		√	√	√
Mikrobac Tissues	√	√	√	√	√	√	√	√
WIP'ANIOS CLEAN'UP		√	√			√		
Oxivir Tb Wipes/Oxivir Tb	√			√			√	√
Oxivir 1 Wipes	√							
Sani-Cloth Bleach Germicidal Disposable Wipe	√	√	√	√	√	√	√	
WIP'ANIOS EXCEL	√			√	√		√	
Super Sani-Cloth Germicidal Disposable Wipe	√	√		√	√	√	√	√
Sani-Cloth Prime Germicidal Disposable Wipe	√	√				√		√
Transeptic CLEANSING SOLUTION	√			√	√		√	
protex disinfectant spray	√	√	√	√	√	√	√	√
Tristel Duo/Tristel Duo ULT/Tristel Duo NCU	√			√	√		√	√
CaviCide	√			√	√		√	
Transeptic Spray								

Trade Name	TEX Series	TE9 Series	Hepatus 7/Hepatus 6/Hepatus 5 Series	ME7/ME8 Series (with trackpad)	MX6/MX5/MX3 Series (with touchpad)	UMT-400/UMT-400Plus Trolley	MT3 Trolley	AirSight (used for running TE Air)
CaviCide 1	√			√			√	
Oxivir 1				√			√	
WIP'ANIOS SPOR'ACTIV			√					
CIDEX OPA	√			√	√		√	
MetriCide OPA Plus								
Milton Sterilising Fluid	√			√	√		√	
Virex II 256	√		√	√	√		√	√
75% Medical alcohol	√	√	√	√	√	√	√	√
3% Hydrogen peroxide	√	√	√	√	√	√	√	√
70% Isopropyl alcohol	√	√		√	√	√	√	√
0.5% Sodium hypochlorite	√	√	√		√	√		√
Virex Tb	√	√	√	√	√	√	√	
CLOROX HEALTHCARE Hydrogen Peroxide Cleaner Disinfectant Wipes	√			√	√		√	√
Tristel Trio Wipes System	√			√	√		√	
CLOROX HEALTHCARE FUZION CLEANER DISINFECTANT	√			√	√		√	
CLOROX HEALTHCARE Bleach Germicidal Wipes	√			√	√		√	√
MATRIX WIPES	√			√	√		√	√
Reynard Premier detergent & disinfectant wipes	√			√	√		√	
Reynard Neutral detergent wipes	√			√	√		√	
trophon Companion Cleaning Wipes	√			√	√		√	
mikrozid universal wipes premium	√			√	√		√	

Table 7-3 Compatible Disinfectants of Cart-based Ultrasound System

NOTE:

The disinfectant marked with * indicates that they can only be used to disinfect the areas of the ultrasound system with Method 2.

Trade Name	Resona A10/Resona A20 Series	Nuewa A10/Nuewa A20 Series	Recho R9 Series	Resona R9/Nuewa R9/Resona R7/Nuewa R7/Resona 7 Series	ViewMate™ Multi	Resona 19/Nuewa 19/Imagyn 19 Series Hepatus 10/Hepatus 9/Hepatus 8 Series	Resona 18/Nuewa 18/Imagyn 18 Series	Consona N6/Nuewa N9/Recho N9 Series	Consona N5 Series
CLEANISEPT WIPES	√	√						√	√
mikrozid AF wipes	√	√						√	√
protex ultra disinfectant wipes	√	√	√	√				√	√
Sani-Cloth Plus Germicidal Disposable Cloth	√	√	√	√	√	√*		√	√
SONO ULTRASOUND WIPES	√	√	√	√	√	√*	√*	√	√
clinell Universal wipes/clinell Surface Wipes	√	√	√		√	√*	√*	√	√
mikrozid sensitive wipes Jumbo				√	√	√*	√*	√	√
WIP'ANIOS Premium	√	√						√	√
Sani-Cloth AF3 Germicidal Disposable Wipe								√	√
Sani-Cloth HB Germicidal Disposable Wipe									
CaviWipes	√	√	√	√	√	√	√	√	√
Mikrobac Tissues	√	√			√	√*	√*	√	√
WIP'ANIOS CLEAN'UP									
Oxivir Tb Wipes/Oxivir Tb	√	√	√	√	√	√*	√*	√	√
Oxivir 1 Wipes	√	√							
Sani-Cloth Bleach Germicidal Disposable Wipe	√	√	√	√				√	√
WIP'ANIOS EXCEL	√	√			√	√*	√*	√	√
Super Sani-Cloth Germicidal Disposable Wipe	√	√	√	√				√	√
Sani-Cloth Prime Germicidal Disposable Wipe	√	√	√		√	√*		√	√
Transeptic CLEANSING SOLUTION	√	√						√	√
protex disinfectant spray	√	√			√	√*	√*	√	√
Tristel Duo/Tristel Duo ULT/Tristel Duo NCU	√	√			√	√*	√*	√	√
CaviCide	√	√	√	√	√	√*	√*	√	√

Trade Name	Resona A10/Resona A20 Series	Nuewa A10/Nuewa A20 Series	Recho R9 Series	Resona R9/Nuewa R9/Resona R7/Nuewa R7/Resona 7 Series	ViewMate™ Multi	Hepatus 10/Hepatus 9/Hepatus 8 Series	Resona 19/Nuewa 19/Imagyn 19 Series	Resona 18/Nuewa 18/Imagyn 18 Series	Consona N6/Nuewa N9/Recho N9 Series	Consona N9/Consona N8/Consona N7/Consona N6	Consona N5 Series
Transeptic Spray					√	√*		√*			
CaviCide 1	√	√							√		√
Oxivir 1									√		√
WIP'ANIOS SPOR'ACTIV											
CIDEX OPA	√	√			√	√*			√		√
MetriCide OPA Plus					√	√*		√*			
Milton Sterilising Fluid	√	√			√	√*		√*	√		√
Virex II 256	√	√	√		√	√*		√*	√		√
75% Medical alcohol	√	√	√		√	√*		√*	√		√
3% Hydrogen peroxide	√	√	√		√	√		√	√		√
70% Isopropyl alcohol	√	√	√		√	√*		√*	√		√
0.5% Sodium hypochlorite	√	√	√	√	√	√*		√*	√		√
Virex Tb					√	√		√	√		√
CLOROX HEALTHCARE Hydrogen Peroxide Cleaner Disinfectant Wipes	√	√		√	√	√		√	√		√
Tristel Trio Wipes System	√	√							√		√
CLOROX HEALTHCARE FUZION CLEANER DISINFECTANT	√	√			√	√*		√*	√		√
CLOROX HEALTHCARE Bleach Germicidal Wipes	√	√			√	√*		√*	√		√
MATRIX WIPES	√	√			√	√*		√*	√		√
Reynard Premier detergent & disinfectant wipes	√	√							√		√
Reynard Neutral detergent wipes	√	√							√		√
trophon Companion Cleaning Wipes	√	√							√		√
mikrozid universal wipes premium	√	√			√	√*		√*	√		√

8 Cleaning Other Accessories

8.1 Cleaning the Holders

Perform the following steps to clean probe holders and coupling gel holders.

1. Use dry soft cloth to wipe off the dust attached to inside, outside or gap of probe holder or gel holder. As to small intra-cavity probe holder or its gap, use the soft brush to brush the dust or stain.
2. Remained stain attached to inside, outside of holder should be washed out by cloth with a little soapy water and then allow it to air dry after take it out.
3. Gel warmer: Take the gel warmer out after pull out the power supply cable, use dry soft cloth to wipe off the dust attached to inside and outside, then brush the dust in the gel warmer or brush the stain with a little soap water and allow it to air dry at last.

8.2 Cleaning the ECG Cables

See the accompanying ECG manual for details.

8.3 Cleaning the Peripherals

Do the cleaning maintenance according to your actual peripheral configuration; items which are not configured can be skipped.

Color and B/W video printer

First wipe off dust or stain attached to the cover of printer with soft dry cloth, then clean the inside of printer. Be sure to do the cleaning maintenance according to the operation manual if necessary.

Graph/text printer

First wipe off dust or stain attached to the cover of printer with soft dry cloth, then clean the inside of printer. Be sure to do the cleaning maintenance according to the operation manual if necessary.

Footswitch

Use soft dry cloth with a little mild soap water to wipe off the dust or stain attached to the pedals or cable of foot switch.

Barcode reader

First use soft dry cloth to wipe off dust attached to glass panel of the reader, then the dust or strain attached to cable and bracket. Refer to barcode reader operator's manual for details.

This page intentionally left blank.

Appendix A Compatible Probe Cleaners and Disinfectants

NOTE:

The content in the list is written based on ultrasound systems manufactured by Mindray. The versions of the ultrasound systems will be updated, and the list may be not updated in time. Therefore, if the desired information cannot be found in this list, contact Mindray customer service department or sales representative.

A.1 Cleaners

- a1: MetriZyme
- a2: Tristel Pre-Clean Wipes
- a3: Liquinox
- a4: Revital-Ox Enzymatic Detergent
- a5: MetriSponge
- a6: Prolystica 2X Concentrate Enzymatic Presoak and Cleaner
- a7: Endozime and Endozime Sponge
- a8: Klenzyme
- a9: ANIOSYME SYNERGY 5
- a10: DDN9
- a11: Reynard Neutral detergent wipes

	Probe	Cleaners
Convex	C5-1s/C5-1E/C5-1U/C5-1/C5-2/C5-2s/C5-2E/ C6-2/C6-2s/C6-2P/C11-3E/C11-3s/C11-3U/C11-3/ C5-1m/mC5-2m/mC11-3m/35C20EA/3C5A/SC6- 1U/SC6-1E/SC6-1s/SC5-1NE/SC5-1Ns/SC5-1N	a1, a2, a3, a4, a5, a6, a7, a9, a10, a11
	C6-2Gs/C6-2GE/C6-2GU/SC7-1U/SC7-1s/SC9- 2U/SC9-2s/SCM7-1U/SC6-1MU/SCM4-1U/SC6- 1GU/C6-1/C6-1m/C5-2m/C5-2m-e/mSC6-1s	a1, a2, a3, a4, a5, a6, a7, a9, a10, a11
	C7-3E/C7-3/3C1/3C1s/6C2/6C2P/6C2s/35C50 EA/35C50EB/35C50P/65C15EAV/65C15EA	a1, a2, a3, a4, a5, a6, a7, a9, a10, a11
	3C5s/3C5P	a1, a2, a3, a4, a5, a6, a7, a9, a10, a11
	SC5-1U/SC5-1E	a1, a2, a3, a4, a5, a6, a7
	SC8-2U/SC8-2s	a1, a8
	C4-1/C4-1U/C4-1s	a1, a3, a4, a5, a6, a7, a11
	C9-3Ts	a1, a3, a4, a5, a6, a7
SC10-2RCs	a9	

- a1: MetriZyme
- a2: Tristel Pre-Clean Wipes
- a3: Liquinox
- a4: Revital-Ox Enzymatic Detergent
- a5: MetriSponge
- a6: Polystica 2X Concentrate Enzymatic Presoak and Cleaner
- a7: Endozime and Endozime Sponge
- a8: Klenzyme
- a9: ANIOSYME SYNERGY 5
- a10: DDN9
- a11: Reynard Neutral detergent wipes

	Probe	Cleaners
Linear	L7-3/L7-3s/L7-3E/7L4s/7L4A/7L4P/7L4B/7L4Bs /7L4BP/7L5/7L5P/7L5s/7L6/7L6s/75L38EA/75L 38EB/75L53EA/75L60EA/75L38P/10L4/10L4s	a1, a2, a3, a4, a5, a6, a7, a9, a10, a11
	65EL60EA/6LE7/6LE7s/6LE7P/6LE5V/ 6LE5Vs/6LE5VP/7LT4/7LT4s/7LT4P/7LT4E/ 50L60EAV/75L50EAV/75LT38EA	a1, a2, a3, a4, a5, a6, a7, a9
	7LT4s (black-white connector)	a1, a2, a3, a4, a5, a6, a7, a9
	L10-3E/L10-3s	a1
	L9-3/L9-3U/L9-3E/L9-3s/L12-3/L12-3E/ L13-3s/L13-3/L12-4/L12-4s/L14-6N/L14- 6Ns/L14-6NP/L14-6NE/L14-6WE/L14- 6Ws/L14-6WU/L13-3m/L18-6m/L9-3m	a1, a2, a3, a4, a5, a6, a7, a9, a10, a11
	L12-3m/L12-3m-e/L12-3Wm	a1, a2, a3, a4, a5, a6, a7, a9, a10, a11
	L11-3U/L11-3VNs/L13-3N/L13-3Ns/L14- 3s/L14-3WU/L14-3WE/L14-3Ws/L14-3W/ L14-3m/SL10-3U/SL10-3s/SLM10-3U	a1, a2, a3, a4, a5, a6, a7, a9, a10, a11
	L11-4/L11-4s/L14-6/L14-6s/L14-6P/10L24EA/ LM14-6E/LM14-6s/LM16-4U	a1, a2, a3, a4, a5, a6, a7, a9, a10, a11
	L16-4HE/L16-4Hs/L16-4HU	a8
	L16-4Hs (black-white connector)	a8
	L20-5U/L20-5s/L20-5E	a1, a3, a4, a5, a6, a7, a9, a10, a11
	L12-3RCs/L12-3VNs/L15-3RCs	a9
	L15-3WE/L15-3WU/L24-6RCs/L24-6Hs/ HS24-6LU/LM18-5WU/LM24-6WU	a9, a10, a11
	L15-3Ws	/
	L14-5sp/HS14-5Lm/L14-5WU/L14-5WE/L14-5Ws	a1, a3, a4, a5, a6, a7, a11
	L30-8U/L33-8U/L33-8s	a8
L9-3PAU	a11	
Phased	P4-2/P4-2s/P4-2E/P4-2NE/P4-2Ns/P10-4E/P10- 4s/P10-4U/P10-4/2P2/2P2s/2P2P/P4-2m/P10-4m	a1, a2, a3, a4, a5, a6, a7, a9, a10, a11
	P7-3/P7-3s/P7-3E/P7-3U/P7-3P	a1, a8
	P12-4/P12-4s	a1
	SP5-1U/SP5-1s/SP5-1E/SP5-1/ SP5-1Ns/SP5-1N/SP5-1m	a1, a2, a3, a4, a5, a6, a7, a9, a10, a11
LFP5-1s/LFP5-1U/LFC5-1s/LFC5-1U	a10	
Phased	P8-2s/P8-2/P8-2U/P8-2P/SP9-2U/ SP9-2s/SPM6-1U/XP5-1U/P8-2m	a1, a2, a3, a4, a5, a6, a7, a9, a10, a11

- a1: MetriZyme
 a2: Tristel Pre-Clean Wipes
 a3: Liquinox
 a4: Revital-Ox Enzymatic Detergent
 a5: MetriSponge
 a6: Prolystica 2X Concentrate Enzymatic Presoak and Cleaner
 a7: Endozime and Endozime Sponge
 a8: Klenszyme
 a9: ANIOSYME SYNERGY 5
 a10: DDN9
 a11: Reynard Neutral detergent wipes

	Probe	Cleaners
Endo-cavity	65EC10EA/65EC10EB/65EC10EC	a1, a2, a3, a4, a5, a6, a7, a9
	V10-4/V10-4s/V10-4B/V10-4Bs/ V10-4BP/6CV1/6CV1s/6CV1P/V10- 4m/V10-4m-B/65EC10ED	a1, a2, a3, a4, a5, a6, a7, a9, a10, a11
	V11-3/V11-3BE/V11-3B/V11-3WE/V11- 3Ws/V11-3E/V11-3m/V11-3m-B	a1, a2, a3, a4, a5, a6, a7, a9, a10, a11
	V11-3s	a1, a2, a3, a4, a5, a6, a7, a9, a10, a11
	V11-3HU/V11-3HE/V11-3Hs/V11-3H/ V11-3HB/SV10-2U/V10-2U	a1, a2, a3, a4, a5, a6, a7, a9, a10, a11
	V11-3HBs/SV10-2s/V10-2s	a1, a2, a3, a4, a5, a6, a7, a9, a10, a11
	V11-3Hs (black-white connector)	a1, a2, a3, a4, a5, a6, a7, a9, a10, a11
	6CV1s (black-white connector)	a1, a2, a3, a4, a5, a6, a7, a9, a10, a11
Pencil	CW2s/CW5s/CW5	/
Biplane	CB10-4/CB10-4P/CB10-4E/CB10-4s	a1, a2, a3, a4, a5, a6, a7, a9
	6LB7/6LB7s/6LB7P/6LB7E/65EB10EA	a1, a2, a3, a4, a5, a6, a7, a9
	ELC13-4U/ELC10-4	a9, a11
	ELC13-4s	a9, a11
4D	4CD4/4CD4s/D6-2E	/
	D7-2/D7-2E/D7-2s/SD8-1E/SD8-1s/SD8- 1/SD8-1U/D6-2/D6-2P/D6-2EA/D6-2B/ D6-2A/D7-2m/D6-2m/SDM9-2U	a1, a2, a3, a4, a5, a6, a7, a9
	D6-2NE/DL14-3U	a1
	D8-2E/D8-2U	/
	D8-4U	/
	DE10-3/DE10-3E/DE10-3U/DE10- 3s (gray strain relief)	/
	DE11-3s/DE11-3E/DE11-3/DE11-3WE/DE11-3Ws/ SDE14-3LU/DE13-5WU/SDE10-2WU/SDE10-2Ws	a1, a2, a3, a4, a5, a6, a7
	DE10-3WU/DE10-3WE (gray strain relief)	a8
	DE10-3Ws/DE10-3WU/DE10-3WE/ DE10-3U (white strain relief)	a11
Ocular	A10e	/

- a1: MetriZyme
- a2: Tristel Pre-Clean Wipes
- a3: Liquinox
- a4: Revital-Ox Enzymatic Detergent
- a5: MetriSponge
- a6: Prolystica 2X Concentrate Enzymatic Presoak and Cleaner
- a7: Endozime and Endozime Sponge
- a8: Klenzyme
- a9: ANIOSYME SYNERGY 5
- a10: DDN9
- a11: Reynard Neutral detergent wipes

Probe		Cleaners
Composite Probe	i5M/z5M/z5Ms/z5Mt/e5M/e5Ms/e5Mt/a5Mx	a1, a2, a3, a4, a5, a6, a7, a9

A.2 Disinfectants

A.2.1 Wipes

b1:	CLEANISEPT WIPES	b25:	WIP'ANIOS CLEAN'UP
b2:	mikrozid AF wipes	b26:	CaviWipes XL
b3:	protex ultra disinfectant wipes	b27:	Oxivir Tb Wipes
b4:	Sani-Cloth Plus Germicidal Disposable Cloth	b28:	Oxivir 1 Wipes
b5:	SONO ULTRASOUND WIPES	b29:	Sani-Cloth Bleach Germicidal Disposable Wipe
b7:	Tristel Sporicidal Wipe	b30:	WIP'ANIOS EXCEL
b8:	Tristel Rinse Wipes	b31:	Virusolve+Pronte all'uso
b9:	clinell Universal wipes/clinell Surface Wipes	b32:	Super Sani-Cloth Germicidal Disposable Wipe
b10:	mikrozid sensitive wipes Jumbo	b33:	Sani-Cloth Prime Germicidal Disposable Wipe
b11:	WIP'ANIOS Premium	b34:	Reynard Premier detergent & disinfectant wipes
b12:	ultrasound probe cleaning wipes	b35:	Gelica Surface Disinfecting Towelettes
b13:	Sani-Cloth AF3 Germicidal Disposable Wipe	b36:	Incidin OxyWipe S
b14:	protex disinfectant wipes	b37:	Kohrsolin FF Tissues
b15:	Sani-Cloth HB Germicidal Disposable Wipe	b38:	Bacillol 30 Tissues
b16:	CaviWipes	b39:	MATRIX WIPES
b17:	Dispatch Towels	b40:	Meliseptol Wipes ultra
b18:	Accel TB Wipes	b41:	CLEANISEPT WIPES FORTE MAXI
b19:	CaviWipes 1		
b20:	TUFFIE 5 UNIVERSAL SANITISING WIPE		
b21:	Sani-Cloth Active Wipes		
b22:	Septiwipes		
b23:	Mikrobac Tissues		
b24:	Sani-Cloth Germicidal Wipes		

	Probe	Wipes
Convex	C5-1s/C5-1E/C5-1U/C5-1/C5-2/C5-2s/C5-2E/C6-2/C6-2s/C6-2P/C11-3E/C11-3s/C11-3U/C11-3/C5-1m/mC5-2m/mC11-3m/35C20EA/3C5A/SC6-1U/SC6-1E/SC6-1s/SC5-1NE/SC5-1Ns/SC5-1N	b1, b2, b3, b4, b5, b7, b8, b9, b10, b11, b12, b13, b16, b18, b19, b24, b25, b26, b27, b28, b29, b30, b32, b33, b34, b35, b36, b37, b38, b39, b40, b41
	C6-2Gs/C6-2GE/C6-2GU/SC7-1U/SC7-1s/SC9-2U/SC9-2s/SCM7-1U/SC6-1MU/SCM4-1U/SC6-1GU/C6-1/C6-1m/C5-2m/C5-2m-e/mSC6-1s	b1, b2, b3, b4, b5, b7, b8, b9, b10, b11, b12, b13, b16, b18, b19, b24, b25, b26, b27, b28, b29, b30, b31, b32, b33, b34, b35, b36, b37, b38, b39, b40, b41
	C7-3E/C7-3/C3C1/3C1s/6C2/6C2P/6C2s/35C50EA/35C50EB/35C50P/65C15EAV/65C15EA	b1, b2, b3, b4, b5, b7, b8, b9, b10, b11, b12, b13, b16, b18, b19, b24, b25, b26, b27, b28, b29, b30, b31, b32, b33, b34, b35, b36, b37, b38, b39, b40, b41
	3C5s/3C5P	b1, b2, b3, b4, b5, b7, b8, b9, b10, b11, b12, b13, b16, b18, b19, b24, b25, b26, b27, b28, b29, b30, b31, b32, b33, b34, b35, b36, b37, b38, b39, b40, b41
	SC5-1U/SC5-1E	b1, b2, b3, b4, b5, b7, b8, b9, b10, b11, b16, b18, b19, b24, b25, b26, b27, b28, b29
	SC8-2U/SC8-2s	b15, b25
	C4-1/C4-1U/C4-1s	b4, b5, b13, b14, b15, b16, b17, b18, b26, b32, b33, b34, b35, b36, b37, b38, b39, b40, b41
	C9-3Ts	b16, b26
	SC10-2RCs	b1, b4, b5, b9, b11, b13, b16, b18, b19, b24, b25, b26, b27, b28, b29, b30, b31, b32, b33

b1: CLEANISEPT WIPES	b25: WIP'ANIOS CLEAN'UP
b2: mikrozyd AF wipes	b26: CaviWipes XL
b3: protex ultra disinfectant wipes	b27: Oxivir Tb Wipes
b4: Sani-Cloth Plus Germicidal Disposable Cloth	b28: Oxivir 1 Wipes
b5: SONO ULTRASOUND WIPES	b29: Sani-Cloth Bleach Germicidal Disposable Wipe
b7: Tristel Sporicidal Wipe	b30: WIP'ANIOS EXCEL
b8: Tristel Rinse Wipes	b31: Virusolve+Pronte all'uso
b9: clinell Universal wipes/clinell Surface Wipes	b32: Super Sani-Cloth Germicidal Disposable Wipe
b10: mikrozyd sensitive wipes Jumbo	b33: Sani-Cloth Prime Germicidal Disposable Wipe
b11: WIP'ANIOS Premium	b34: Reynard Premier detergent & disinfectant wipes
b12: ultrasound probe cleaning wipes	b35: Gelica Surface Disinfecting Towelettes
b13: Sani-Cloth AF3 Germicidal Disposable Wipe	b36: Incidin OxyWipe S
b14: protex disinfectant wipes	b37: Kohrsolin FF Tissues
b15: Sani-Cloth HB Germicidal Disposable Wipe	b38: Bacillol 30 Tissues
b16: CaviWipes	b39: MATRIX WIPES
b17: Dispatch Towels	b40: Meliseptol Wipes ultra
b18: Accel TB Wipes	b41: CLEANISEPT WIPES FORTE MAXI
b19: CaviWipes 1	
b20: TUFFIE 5 UNIVERSAL SANITISING WIPE	
b21: Sani-Cloth Active Wipes	
b22: Septiwipes	
b23: Mikrobac Tissues	
b24: Sani-Cloth Germicidal Wipes	

Probe		Wipes
Linear	L7-3/L7-3s/L7-3E/7L4s/7L4A/7L4P/7L4B/7L4Bs/7L4BP/7L5/7L5P/7L5s/7L6/7L6s/75L38EA/75L38EB/75L53EA/75L60EA/75L38P/10L4/10L4s	b1, b2, b3, b4, b5, b7, b8, b9, b10, b11, b12, b13, b16, b18, b19, b24, b25, b26, b27, b28, b29, b30, b31, b32, b33, b34, b35, b36, b37, b38, b39, b40, b41
	65EL60EA/6LE7/6LE7s/6LE7P/6LE5V/6LE5Vs/6LE5VP/7LT4/7LT4s/7LT4P/7LT4E/50L60EAV/75L50EAV/75LT38EA	b1, b2, b3, b4, b5, b7, b8, b10, b11, b12, b16, b18, b19, b24, b25, b26, b27, b28, b29, b30, b31
	7LT4s (black-white connector)	b1, b2, b3, b4, b5, b7, b8, b10, b11, b12, b16, b18, b19, b24, b25, b26, b27, b28, b29, b30, b31
	L10-3E/L10-3s	b25
	L9-3/L9-3U/L9-3E/L9-3s/L12-3/L12-3E/L13-3s/L13-3/L12-4/L12-4s/L14-6N/L14-6Ns/L14-6NP/L14-6NE/L14-6WE/L14-6Ws/L14-6WU/L13-3m/L18-6m/L9-3m	b1, b2, b3, b4, b5, b7, b8, b9, b10, b11, b12, b13, b16, b18, b19, b24, b25, b26, b27, b28, b29, b30, b32, b33, b34, b35, b36, b37, b38, b39, b40, b41
	L12-3m/L12-3m-e/L12-3Wm	b1, b2, b3, b4, b5, b7, b8, b9, b10, b11, b12, b13, b16, b18, b19, b24, b25, b26, b27, b28, b29, b30, b31, b32, b33, b34, b35, b36, b37, b38, b39, b40, b41
	L11-3U/L11-3VNs/L13-3N/L13-3Ns/L14-3s/L14-3WU/L14-3WE/L14-3Ws/L14-3W/L14-3m/SL10-3U/SL10-3s/SLM10-3U	b1, b2, b3, b4, b5, b7, b8, b9, b10, b11, b12, b13, b16, b18, b19, b24, b25, b26, b27, b28, b29, b30, b31, b32, b33, b34, b35, b36, b37, b38, b39, b40, b41
	L11-4/L11-4s/L14-6/L14-6s/L14-6P/10L24EA/LM14-6E/LM14-6s/LM16-4U	b1, b2, b3, b4, b5, b7, b8, b9, b10, b11, b12, b13, b16, b18, b19, b24, b25, b26, b27, b28, b29, b30, b32, b33, b34, b35, b36, b37, b38, b39, b40, b41
	L16-4HE/L16-4Hs/L16-4HU	/
L16-4Hs (black-white connector)	/	

b1: CLEANISEPT WIPES	b25: WIP'ANIOS CLEAN'UP
b2: mikrozyd AF wipes	b26: CaviWipes XL
b3: protex ultra disinfectant wipes	b27: Oxivir Tb Wipes
b4: Sani-Cloth Plus Germicidal Disposable Cloth	b28: Oxivir 1 Wipes
b5: SONO ULTRASOUND WIPES	b29: Sani-Cloth Bleach Germicidal Disposable Wipe
b7: Tristel Sporicidal Wipe	b30: WIP'ANIOS EXCEL
b8: Tristel Rinse Wipes	b31: Virusolve+Pronte all'uso
b9: clinell Universal wipes/clinell Surface Wipes	b32: Super Sani-Cloth Germicidal Disposable Wipe
b10: mikrozyd sensitive wipes Jumbo	b33: Sani-Cloth Prime Germicidal Disposable Wipe
b11: WIP'ANIOS Premium	b34: Reynard Premier detergent & disinfectant wipes
b12: ultrasound probe cleaning wipes	b35: Gelica Surface Disinfecting Towelettes
b13: Sani-Cloth AF3 Germicidal Disposable Wipe	b36: Incidin OxyWipe S
b14: protex disinfectant wipes	b37: Kohrsolin FF Tissues
b15: Sani-Cloth HB Germicidal Disposable Wipe	b38: Bacillol 30 Tissues
b16: CaviWipes	b39: MATRIX WIPES
b17: Dispatch Towels	b40: Meliseptol Wipes ultra
b18: Accel TB Wipes	b41: CLEANISEPT WIPES FORTE MAXI
b19: CaviWipes 1	
b20: TUFFIE 5 UNIVERSAL SANITISING WIPE	
b21: Sani-Cloth Active Wipes	
b22: Septiwipes	
b23: Mikrobac Tissues	
b24: Sani-Cloth Germicidal Wipes	

	Probe	Wipes
Linear	L20-5U/L20-5s/L20-5E	b4, b5, b13, b14, b15, b16, b17, b18, b25, b26, b31, b34, b35, b36, b37, b38, b39, b40, b41
	L12-3RCs/L12-3VNs/L15-3RCs	b1, b4, b5, b9, b11, b13, b16, b18, b19, b24, b25, b26, b27, b28, b29, b30, b31, b32, b33
	L15-3WE/L15-3WU/L24-6RCs/L24-6Hs/HS24-6LU/LM18-5WU/LM24-6WU	b9, b13, b25, b29, b30, b31, b32, b33, b34, b35, b36, b37, b38, b39, b40, b41
	L15-3Ws	b9, b33
	L14-5sp/HS14-5Lm/L14-5WU/L14-5WE/L14-5Ws	b4, b5, b13, b14, b15, b16, b17, b18, b26, b32, b33, b34, b35, b36, b37, b38, b39, b40, b41
	L30-8U/L33-8U/L33-8s	/
	L9-3PAU	b34, b35, b36, b37, b38
Phased	P4-2/P4-2s/P4-2E/P4-2NE/P4-2Ns/P10-4E/P10-4s/P10-4U/P10-4/2P2/2P2s/2P2P/P4-2m/P10-4m	b1, b2, b3, b4, b5, b7, b8, b9, b10, b11, b12, b13, b16, b18, b19, b24, b25, b26, b27, b28, b29, b30, b31, b32, b33, b34, b35, b36, b37, b38, b39, b40, b41
	P7-3/P7-3s/P7-3E/P7-3U/P7-3P	b3, b4, b15, b25, b29
	P12-4/P12-4s	b5, b25, b29
	SP5-1U/SP5-1s/SP5-1E/SP5-1/SP5-1Ns/SP5-1N/SP5-1m	b1, b2, b3, b4, b5, b7, b8, b9, b10, b11, b12, b13, b16, b18, b19, b24, b25, b26, b27, b28, b29, b30, b32, b33, b34, b35, b36, b37, b38, b39, b40, b41
	LFP5-1s/LFP5-1U/LFC5-1s/LFC5-1U	b1, b4, b5, b11, b13, b16, b18, b19, b24, b26, b27, b28, b32, b33
P8-2s/P8-2/P8-2U/P8-2P/SP9-2U/SP9-2s/SPM6-1U/XP5-1U/P8-2m	b1, b2, b3, b4, b5, b7, b8, b9, b10, b11, b12, b13, b16, b18, b19, b24, b25, b26, b27, b28, b29, b30, b31, b32, b33, b34, b35, b36, b37, b38, b39, b40, b41	

b1:	CLEANISEPT WIPES	b25:	WIP'ANIOS CLEAN'UP
b2:	mikrozid AF wipes	b26:	CaviWipes XL
b3:	protex ultra disinfectant wipes	b27:	Oxivir Tb Wipes
b4:	Sani-Cloth Plus Germicidal Disposable Cloth	b28:	Oxivir 1 Wipes
b5:	SONO ULTRASOUND WIPES	b29:	Sani-Cloth Bleach Germicidal Disposable Wipe
b7:	Tristel Sporicidal Wipe	b30:	WIP'ANIOS EXCEL
b8:	Tristel Rinse Wipes	b31:	Virusolve+Pronte all'uso
b9:	clinell Universal wipes/clinell Surface Wipes	b32:	Super Sani-Cloth Germicidal Disposable Wipe
b10:	mikrozid sensitive wipes Jumbo	b33:	Sani-Cloth Prime Germicidal Disposable Wipe
b11:	WIP'ANIOS Premium	b34:	Reynard Premier detergent & disinfectant wipes
b12:	ultrasound probe cleaning wipes	b35:	Gelica Surface Disinfecting Towelettes
b13:	Sani-Cloth AF3 Germicidal Disposable Wipe	b36:	Incidin OxyWipe S
b14:	protex disinfectant wipes	b37:	Kohrsolin FF Tissues
b15:	Sani-Cloth HB Germicidal Disposable Wipe	b38:	Bacillol 30 Tissues
b16:	CaviWipes	b39:	MATRIX WIPES
b17:	Dispatch Towels	b40:	Meliseptol Wipes ultra
b18:	Accel TB Wipes	b41:	CLEANISEPT WIPES FORTE MAXI
b19:	CaviWipes 1		
b20:	TUFFIE 5 UNIVERSAL SANITISING WIPE		
b21:	Sani-Cloth Active Wipes		
b22:	Septiwipes		
b23:	Mikrobac Tissues		
b24:	Sani-Cloth Germicidal Wipes		

	Probe	Wipes
Endo-cavity	65EC10EA/65EC10EB/65EC10EC	b1, b2, b3, b4, b5, b7, b8, b10, b11, b12, b16, b18, b19, b24, b25, b26, b27, b28, b29, b30, b31
	V10-4/V10-4s/V10-4B/V10-4Bs/V10-4BP/6CV1/6CV1s/6CV1P/V10-4m/V10-4m-B/65EC10ED	b1, b2, b3, b4, b5, b7, b8, b9, b10, b11, b12, b13, b16, b18, b19, b24, b25, b26, b27, b28, b29, b30, b31, b32, b33, b34, b35, b36, b37, b38, b39, b40, b41
	V11-3/V11-3BE/V11-3B/V11-3WE/V11-3Ws/V11-3E/V11-3m/V11-3m-B	b1, b2, b3, b4, b5, b7, b8, b9, b10, b11, b12, b13, b16, b18, b19, b24, b25, b26, b27, b28, b29, b30, b32, b33, b34, b35, b36, b37, b38, b39, b40, b41
	V11-3s	b1, b2, b3, b4, b5, b7, b8, b9, b10, b11, b12, b13, b16, b18, b19, b24, b25, b26, b27, b28, b29, b30, b32, b33, b34, b35, b36, b37, b38, b39, b40, b41
	V11-3HU/V11-3HE/V11-3Hs/V11-3H/V11-3HB/SV10-2U/V10-2U	b1, b2, b3, b4, b5, b7, b8, b9, b10, b11, b12, b13, b16, b18, b19, b24, b25, b26, b27, b28, b29, b30, b31, b32, b33, b34, b35, b36, b37, b38, b39, b40, b41
	V11-3HBs/SV10-2s/V10-2s V11-3Hs (black-white connector)	b1, b2, b3, b4, b5, b7, b8, b9, b10, b11, b12, b13, b16, b18, b19, b24, b25, b26, b27, b28, b29, b30, b31, b32, b33, b34, b35, b36, b37, b38, b39, b40, b41
	6CV1s (black-white connector)	b1, b2, b3, b4, b5, b7, b8, b9, b10, b11, b12, b13, b16, b18, b19, b24, b25, b26, b27, b28, b29, b30, b31, b32, b33, b34, b35, b36, b37, b38, b39, b40, b41
Pencil	CW2s/CW5s/CW5	/

- | | |
|---------------------------------------------------|-----------------------------------------------------|
| b1: CLEANISEPT WIPES | b25: WIP'ANIOS CLEAN'UP |
| b2: mikrozyd AF wipes | b26: CaviWipes XL |
| b3: protex ultra disinfectant wipes | b27: Oxivir Tb Wipes |
| b4: Sani-Cloth Plus Germicidal Disposable Cloth | b28: Oxivir 1 Wipes |
| b5: SONO ULTRASOUND WIPES | b29: Sani-Cloth Bleach Germicidal Disposable Wipe |
| b7: Tristel Sporicidal Wipe | b30: WIP'ANIOS EXCEL |
| b8: Tristel Rinse Wipes | b31: Virusolve+Pronte all'uso |
| b9: clinell Universal wipes/clinell Surface Wipes | b32: Super Sani-Cloth Germicidal Disposable Wipe |
| b10: mikrozyd sensitive wipes Jumbo | b33: Sani-Cloth Prime Germicidal Disposable Wipe |
| b11: WIP'ANIOS Premium | b34: Reynard Premier detergent & disinfectant wipes |
| b12: ultrasound probe cleaning wipes | b35: Gelica Surface Disinfecting Towelettes |
| b13: Sani-Cloth AF3 Germicidal Disposable Wipe | b36: Incidin OxyWipe S |
| b14: protex disinfectant wipes | b37: Kohrsolin FF Tissues |
| b15: Sani-Cloth HB Germicidal Disposable Wipe | b38: Bacillo 30 Tissues |
| b16: CaviWipes | b39: MATRIX WIPES |
| b17: Dispatch Towels | b40: Meliseptol Wipes ultra |
| b18: Accel TB Wipes | b41: CLEANISEPT WIPES FORTE MAXI |
| b19: CaviWipes 1 | |
| b20: TUFFIE 5 UNIVERSAL SANITISING WIPE | |
| b21: Sani-Cloth Active Wipes | |
| b22: Septiwipes | |
| b23: Mikrobac Tissues | |
| b24: Sani-Cloth Germicidal Wipes | |

Probe		Wipes
Biplane	CB10-4/CB10-4P/CB10-4E/CB10-4s	b1, b2, b3, b4, b5, b7, b8, b10, b11, b12, b16, b18, b19, b24, b25, b26, b27, b28, b29, b30, b31
	6LB7/6LB7s/6LB7P/6LB7E/65EB10EA	b1, b2, b3, b4, b5, b7, b8, b10, b11, b12, b16, b18, b19, b24, b25, b26, b27, b28, b29, b30, b31
	ELC13-4U/ELC10-4	b1, b4, b5, b11, b16, b18, b19, b24, b26, b27, b28, b30, b31, b34, b35, b36, b37, b38, b39, b40, b41
	ELC13-4s	b1, b4, b5, b11, b16, b18, b19, b24, b26, b27, b28, b30, b31, b34, b35, b36, b37, b38, b39, b40, b41
4D	4CD4/4CD4s/D6-2E	/
	D7-2/D7-2E/D7-2s/SD8-1E/SD8-1s/SD8-1/SD8-1U/D6-2/D6-2P/D6-2EA/D6-2B/D6-2A/D7-2m/D6-2m/SDM9-2U	b1, b2, b3, b4, b5, b7, b8, b9, b10, b11, b12, b13, b16, b18, b19, b24, b25, b26, b27, b28, b29, b30, b31, b32, b33
	D6-2NE/DL14-3U	/
	D8-2E/D8-2U	b10, b16, b19, b20, b21
	D8-4U	b4, b10, b16, b19, b20
	DE10-3/DE10-3E/DE10-3U/DE10-3s (gray strain relief)	b10, b16, b19, b20, b21, b32, b33
	DE11-3s/DE11-3E/DE11-3/DE11-3WE/DE11-3Ws/SDE14-3LU/DE13-5WU/SDE10-2WU/SDE10-2Ws	b1, b2, b3, b4, b5, b7, b8, b9, b10, b11, b12, b13, b16, b18, b19, b24, b25, b26, b27, b28, b32, b33
	DE10-3WU/DE10-3WE (gray strain relief)	b1, b12, b15, b16, b20, b21, b22, b23, b24
DE10-3Ws/DE10-3WU/DE10-3WE/DE10-3U (white strain relief)	b34, b35	
Ocular	A10e	/

b1:	CLEANISEPT WIPES	b25:	WIP'ANIOS CLEAN'UP
b2:	mikrozid AF wipes	b26:	CaviWipes XL
b3:	protex ultra disinfectant wipes	b27:	Oxivir Tb Wipes
b4:	Sani-Cloth Plus Germicidal Disposable Cloth	b28:	Oxivir 1 Wipes
b5:	SONO ULTRASOUND WIPES	b29:	Sani-Cloth Bleach Germicidal Disposable Wipe
b7:	Tristel Sporicidal Wipe	b30:	WIP'ANIOS EXCEL
b8:	Tristel Rinse Wipes	b31:	Virusolve+Pronte all'uso
b9:	clinell Universal wipes/clinell Surface Wipes	b32:	Super Sani-Cloth Germicidal Disposable Wipe
b10:	mikrozid sensitive wipes Jumbo	b33:	Sani-Cloth Prime Germicidal Disposable Wipe
b11:	WIP'ANIOS Premium	b34:	Reynard Premier detergent & disinfectant wipes
b12:	ultrasound probe cleaning wipes	b35:	Gelica Surface Disinfecting Towelettes
b13:	Sani-Cloth AF3 Germicidal Disposable Wipe	b36:	Incidin OxyWipe S
b14:	protex disinfectant wipes	b37:	Kohrsolin FF Tissues
b15:	Sani-Cloth HB Germicidal Disposable Wipe	b38:	Bacillo 30 Tissues
b16:	CaviWipes	b39:	MATRIX WIPES
b17:	Dispatch Towels	b40:	Meliseptol Wipes ultra
b18:	Accel TB Wipes	b41:	CLEANISEPT WIPES FORTE MAXI
b19:	CaviWipes 1		
b20:	TUFFIE 5 UNIVERSAL SANITISING WIPE		
b21:	Sani-Cloth Active Wipes		
b22:	Septiwipes		
b23:	Mikrobac Tissues		
b24:	Sani-Cloth Germicidal Wipes		

Probe		Wipes
Composite probe	i5M/z5M/z5Ms/z5Mt/e5M/e5Ms/e5Mt/a5Mx	b1, b2, b4, b5, b7, b8, b9, b10, b11, b12, b13, b14, b16, b18, b19, b24, b25, b26, b27, b29, b30, b31, b32, b33

A.2.2 Sprays

c1: Oxivir Tb	c13: Transeptic Spray
c2: PI-SPRAY II	c14: CaviCide 1
c3: ANIOS SUREA'SAFE PREMIUM	c15: Oxivir 1
c4: Transeptic CLEANSING SOLUTION	c16: WIP'ANIOS SPOR'ACTIV
c5: protex disinfectant spray	c17: Accel TB Liquid
c7: Tristel Duo/Tristel Duo ULT/Tristel Duo NCU	c18: Sani-HyPerCide GERMICIDAL SPRAY
c8: ANIOS IODOCLEAN	c19: Sani-24 GERMICIDAL SPRAY
c9: Protex spray	
c10: CaviCide	
c11: T-Spray	
c12: Indican Form	

Probe		Sprays
Convex	C5-1s/C5-1E/C5-1U/C5-1/C5-2/C5-2s/C5-2E/C6-2/ C6-2s/C6-2P/C11-3E/C11-3s/C11-3U/C11-3/C5- 1m/mC5-2m/mC11-3m/35C20EA/3C5A/SC6-1U/ SC6-1E/SC6-1s/SC5-1NE/SC5-1Ns/SC5-1N	c1, c2, c3, c5, c7, c8, c14, c15, c16, c17, c18, c19
	C6-2Gs/C6-2GE/C6-2GU/SC7-1U/SC7-1s/ SC9-2U/SC9-2s/SCM7-1U/SC6-1MU/SCM4-1U/ SC6-1GU/C6-1/C6-1m/C5-2m/C5-2m-e/mSC6-1s	c1, c2, c3, c5, c7, c8, c14, c15, c16, c17, c18, c19
	C7-3E/C7-3/C3C1/3C1s/6C2/6C2P/6C2s/35C50 EA/35C50EB/35C50P/65C15EAV/65C15EA	c1, c2, c3, c4, c5, c7, c8, c14, c15, c16, c17, c18, c19
	3C5s/3C5P	c1, c2, c3, c4, c5, c7, c8, c14, c15, c16, c17, c18, c19
	SC5-1U/SC5-1E	c1, c2, c3, c5, c7, c14, c15, c16, c17
	SC8-2U/SC8-2s	c4, c11, c16
	C4-1/C4-1U/C4-1s	c2, c9
	C9-3Ts	c18, c19
SC10-2RCs	c1, c3, c7, c14, c15, c16, c17, c18, c19	
Linear	L7-3/L7-3s/L7-3E/7L4s/7L4A/7L4P/7L4B/7L4Bs/ 7L4BP/7L5/7L5P/7L5s/7L6/7L6s/75L38EA/75L3 8EB/75L53EA/75L60EA/75L38P/10L4/10L4s	c1, c2, c3, c4, c5, c7, c8, c14, c15, c16, c17, c18, c19
	65EL60EA/6LE7/6LE7s/6LE7P/6LE5V/ 6LE5Vs/6LE5VP/7LT4/7LT4s/7LT4P/7LT4E/ 50L60EAV/75L50EAV/75LT38EA	c1, c2, c3, c4, c5, c7, c14, c15, c16, c17, c18, c19
	7LT4s (black-white connector)	c1, c2, c3, c4, c5, c7, c14, c15, c16, c17, c18, c19
	L10-3E/L10-3s	c5
	L9-3/L9-3U/L9-3E/L9-3s/L12-3/L12-3E/ L13-3s/L13-3/L12-4/L12-4s/L14-6N/ L14-6Ns/L14-6NP/L14-6NE/L14-6WE/ L14-6Ws/L14-6WU/L13-3m/L18-6m/L9-3m	c1, c2, c3, c5, c7, c8, c14, c15, c16, c17, c18, c19
	L12-3m/L12-3m-e/L12-3Wm	c1, c2, c3, c4, c5, c7, c8, c14, c15, c16, c17, c18, c19
	L11-3U/L11-3VNs/L13-3N/L13-3Ns/L14- 3s/L14-3WU/L14-3WE/L14-3Ws/L14-3W/ L14-3m/SL10-3U/SL10-3s/SLM10-3U	c1, c2, c3, c5, c7, c8, c14, c15, c16, c17, c18, c19
	L11-4/L11-4s/L14-6/L14-6s/L14-6P/10L24EA/ LM14-6E/LM14-6s/LM16-4U	c1, c2, c3, c5, c7, c8, c14, c15, c16, c17, c18, c19
L16-4HE/L16-4Hs/L16-4HU	/	

- | | |
|-------------------------------------------------|-------------------------|
| c1: Oxivir Tb | c13: Transeptic Spray |
| c2: PI-SPRAY II | c14: CaviCide 1 |
| c3: ANIOS SUREA'SAFE PREMIUM | c15: Oxivir 1 |
| c4: Transeptic CLEANSING SOLUTION | c16: WIP'ANIOS |
| c5: protex disinfectant spray | SPOR'ACTIV |
| c7: Tristel Duo/Tristel Duo ULT/Tristel Duo NCU | c17: Accel TB Liquid |
| c8: ANIOS IODOCLEAN | c18: Sani-HyPerCide |
| c9: Protex spray | GERMICIDAL SPRAY |
| c10: CaviCide | c19: Sani-24 GERMICIDAL |
| c11: T-Spray | SPRAY |
| c12: Indican Form | |

Probe		Sprays
Linear	L16-4Hs (black-white connector)	/
	L20-5U/L20-5s/L20-5E	c2, c9
	L12-3RCs/L12-3VNs/L15-3RCs	c1, c3, c7, c14, c15, c16, c17, c18, c19
	L15-3WE/L15-3WU/L24-6RCs/L24-6Hs/HS24-6LU/LM18-5WU/LM24-6WU	c7, c16, c18, c19
	L15-3Ws	c7
	L14-5sp/HS14-5Lm/L14-5WU/L14-5WE/L14-5Ws	c2, c9
	L30-8U/L33-8U/L33-8s	/
Phased	L9-3PAU	c18, c19
	P4-2/P4-2s/P4-2E/P4-2NE/P4-2Ns/P10-4E/P10-4s/P10-4U/P10-4/2P2/2P2s/2P2P/P4-2m/P10-4m	c1, c2, c3, c4, c5, c7, c8, c14, c15, c16, c17, c18, c19
	P7-3/P7-3s/P7-3E/P7-3U/P7-3P	c2, c4, c5, c16
	P12-4/P12-4s	c1, c2, c5, c16
	SP5-1U/SP5-1s/SP5-1E/SP5-1/SP5-1Ns/SP5-1N/SP5-1m	c1, c2, c3, c5, c7, c8, c14, c15, c16, c17, c18, c19
	LFP5-1s/LFP5-1U/LFC5-1s/LFC5-1U	c1, c3, c14, c15, c17, c18, c19
Endo-cavity	P8-2s/P8-2/P8-2U/P8-2P/SP9-2U/SP9-2s/SPM6-1U/XP5-1U/P8-2m	c1, c2, c3, c5, c7, c8, c14, c15, c16, c17, c18, c19
	65EC10EA/65EC10EB/65EC10EC	c1, c2, c3, c4, c5, c7, c14, c15, c16, c17, c18, c19
	V10-4/V10-4s/V10-4B/V10-4Bs/V10-4BP/6CV1/6CV1s/6CV1P/V10-4m/V10-4m-B/65EC10ED	c1, c2, c3, c4, c5, c7, c8, c14, c15, c16, c17, c18, c19
	V11-3/V11-3BE/V11-3B/V11-3WE/V11-3Ws/V11-3E/V11-3m/V11-3m-B	c1, c2, c3, c4, c5, c7, c8, c14, c15, c16, c17, c18, c19
	V11-3s	c1, c2, c3, c4, c5, c7, c8, c14, c15, c16, c17, c18, c19
	V11-3HU/V11-3HE/V11-3Hs/V11-3H/V11-3HB/SV10-2U/V10-2U	c1, c2, c3, c5, c7, c8, c14, c15, c16, c17, c18, c19
	V11-3HBs/SV10-2s/V10-2s	c1, c2, c3, c5, c7, c8, c14, c15, c16, c17, c18, c19
V11-3Hs (black-white connector)	c1, c2, c3, c4, c5, c7, c8, c14, c15, c16, c17, c18, c19	
Pencil	6CV1s (black-white connector)	c1, c2, c3, c4, c5, c7, c8, c14, c15, c16, c17, c18, c19
	CW2s/CW5s/CW5	/

- | | |
|-------------------------------------------------|-------------------------|
| c1: Oxivir Tb | c13: Transeptic Spray |
| c2: PI-SPRAY II | c14: CaviCide 1 |
| c3: ANIOS SUREA'SAFE PREMIUM | c15: Oxivir 1 |
| c4: Transeptic CLEANSING SOLUTION | c16: WIP'ANIOS |
| c5: protex disinfectant spray | SPOR'ACTIV |
| c7: Tristel Duo/Tristel Duo ULT/Tristel Duo NCU | c17: Accel TB Liquid |
| c8: ANIOS IODOCLEAN | c18: Sani-HyPerCide |
| c9: Protex spray | GERMICIDAL SPRAY |
| c10: CaviCide | c19: Sani-24 GERMICIDAL |
| c11: T-Spray | SPRAY |
| c12: Indican Form | |

Probe		Sprays
Biplane	CB10-4/CB10-4P/CB10-4E/CB10-4s	c1, c2, c3, c4, c5, c7, c14, c15, c16, c17, c18, c19
	6LB7/6LB7s/6LB7P/6LB7E/65EB10EA	c1, c2, c3, c4, c5, c7, c14, c15, c16, c17, c18, c19
	ELC13-4U/ELC10-4	c1, c3, c7, c14, c15, c17
	ELC13-4s	c1, c3, c7, c14, c15, c17
4D	4CD4/4CD4s/D6-2E	/
	D7-2/D7-2E/D7-2s/SD8-1E/SD8-1s/SD8-1/SD8-1U/D6-2/D6-2P/D6-2EA/D6-2B/D6-2A/D7-2m/D6-2m/SDM9-2U	c1, c2, c3, c4, c5, c7, c8, c14, c15, c16, c17, c18, c19
	D6-2NE/DL14-3U	/
	D8-2E/D8-2U	c2, c10
	D8-4U	c2, c10, c11
	DE10-3/DE10-3E/DE10-3U/DE10-3s (gray strain relief)	c2, c10, c11
	DE11-3s/DE11-3E/DE11-3/DE11-3WE/DE11-3Ws/SDE14-3LU/DE13-5WU/SDE10-2WU/SDE10-2Ws	c1, c2, c3, c5, c7, c8, c14, c15, c17, c18, c19
	DE10-3WU/DE10-3WE (gray strain relief)	c2, c11, c12, c13
	DE10-3Ws/DE10-3WU/DE10-3WE/DE10-3U (white strain relief)	c18
Ocular	A10e	/
Composite Probe	i5M/z5M/z5Ms/z5Mt/e5M/e5Ms/e5Mt/a5Mx	c1, c2, c3, c7, c8, c14, c15, c17, c19

A.2.3 Solutions

d1: CIDEX OPA	d16: Cidexplus
d2: Cidex Activated Dialdehyde Solution	d17: Gigasept Instru AF
d3: Minncare Cold Sterilant	d18: Osvan
d4: Ster-Bac	d19: Neojodin
d5: Triacid-N	d20: Milton Sterilising Fluid
d6: Revital-Ox Resert High Level Disinfectant	d21: hibitane
d7: gigasept PAA concentrate	d22: Sterihyde
d8: DESCOTON EXTRA	d23: MetriCide 14
d9: Gigasept FF (neu)	d24: Sekusept PLUS
d10: ANIOXYDE 1000	d25: Wavicide-01
d11: SALVANIOS pH10	d26: SALVANIOS pH7
d12: CaviCide Liquid	d27: Minncare liquid disinfectant
d13: MetriCide	d28: Virusolve+Concentrate
d14: MetriCide 28	d29: Virex II 256
d15: MetriCide OPA Plus	d30: UltrOx High-Level disinfectant

	Probe	Solutions
Convex	C5-1s/C5-1E/C5-1U/C5-1/C5-2/C5-2s/ C5-2E/C6-2/C6-2s/C6-2P/C11-3E/C11- 3s/C11-3U/C11-3/C5-1m/mC5-2m/mC11- 3m/35C20EA/3C5A/SC6-1U/SC6-1E/ SC6-1s/SC5-1NE/SC5-1Ns/SC5-1N	d1, d4, d5, d6, d7, d8, d9, d10, d11, d12, d26, d29, d30
	C6-2Gs/C6-2GE/C6-2GU/SC7-1U/SC7-1s/ SC9-2U/SC9-2s/SCM7-1U/SC6- 1MU/SCM4-1U/SC6-1GU/C6-1/C6- 1m/C5-2m/C5-2m-e/mSC6-1s	d1, d3, d4, d5, d6, d7, d8, d9, d10, d11, d12, d15, d26, d27, d28, d29, d30
	C7-3E/C7-3/3C1/3C1s/6C2/6C2 P/6C2s/35C50EA/35C50EB/35 C50P/65C15EAV/65C15EA	d1, d2, d3, d4, d5, d6, d7, d8, d9, d10, d11, d12, d13, d14, d15, d26, d27, d28, d29, d30
	3C5s/3C5P	d1, d2, d3, d4, d5, d6, d7, d8, d9, d10, d11, d12, d13, d14, d15, d26, d27, d28, d29, d30
	SC5-1U/SC5-1E	d1, d4, d6, d12, d15, d30
	SC8-2U/SC8-2s	d1, d9, d16, d20, d25
	C4-1/C4-1U/C4-1s	d1, d2, d6, d12, d13, d14, d15, d30
	C9-3Ts	d1, d6, d12, d13, d14, d15, d30
	SC10-2RCs	d12, d28
Linear	L7-3/L7-3s/L7-3E/7L4s/7L4A/7L4P/7 L4B/7L4Bs/7L4BP/7L5/7L5P/7L5s/7 L6/7L6s/75L38EA/75L38EB/75L53E A/75L60EA/75L38P/10L4/10L4s	d1, d2, d3, d4, d5, d6, d7, d8, d9, d10, d11, d12, d13, d14, d15, d26, d27, d28, d29, d30
	65EL60EA/6LE7/6LE7s/6LE7P/6LE5V/ 6LE5Vs/6LE5VP/7LT4/7LT4s/7LT4P/7LT4E/ 50L60EAV/75L50EAV/75LT38EA	d1, d2, d3, d4, d5, d6, d12, d13, d14, d15, d27, d28, d30
	7LT4s (black-white connector)	d1, d2, d3, d4, d5, d6, d12, d13, d14, d15, d27, d28, d30
	L10-3E/L10-3s	d1, d25
	L9-3/L9-3U/L9-3E/L9-3s/L12-3/L12-3E/ L13-3s/L13-3/L12-4/L12-4s/L14-6N/ L14-6Ns/L14-6NP/L14-6NE/L14-6WE/ L14-6Ws/L14-6WU/L13-3m/L18-6m/L9-3m	d1, d4, d5, d6, d7, d8, d9, d10, d11, d12, d26, d29, d30
	L12-3m/L12-3m-e/L12-3Wm	d1, d2, d3, d4, d5, d6, d7, d8, d9, d10, d11, d12, d13, d14, d15, d26, d27, d28, d29, d30

d1: CIDEX OPA	d16: Cidexplus
d2: Cidex Activated Dialdehyde Solution	d17: Gigasept Instru AF
d3: Minncare Cold Sterilant	d18: Osvan
d4: Ster-Bac	d19: Neojodin
d5: Triacid-N	d20: Milton Sterilising Fluid
d6: Revital-Ox Resert High Level Disinfectant	d21: hibitane
d7: gigasept PAA concentrate	d22: Sterihyde
d8: DESCOTON EXTRA	d23: MetriCide 14
d9: Gigasept FF (neu)	d24: Sekusept PLUS
d10: ANIOXYDE 1000	d25: Wavicide-01
d11: SALVANIOS pH10	d26: SALVANIOS pH7
d12: CaviCide Liquid	d27: Minncare liquid disinfectant
d13: MetriCide	d28: Virusolve+Concentrate
d14: MetriCide 28	d29: Virex II 256
d15: MetriCide OPA Plus	d30: UltrOx High-Level disinfectant

Probe		Solutions
Linear	L11-3U/L11-3VNs/L13-3N/L13-3Ns/L14-3s/L14-3WU/L14-3WE/L14-3Ws/L14-3W/L14-3m/SL10-3U/SL10-3s/SLM10-3U	d1, d3, d4, d5, d6, d7, d8, d9, d10, d11, d12, d15, d26, d27, d28, d29, d30
	L11-4/L11-4s/L14-6/L14-6s/L14-6P/10L24EA/LM14-6E/LM14-6s/LM16-4U	d1, d4, d5, d6, d7, d8, d9, d10, d11, d12, d26, d29, d30
	L16-4HE/L16-4Hs/L16-4HU	d1, d2
	L16-4Hs (black-white connector)	d1, d2
	L20-5U/L20-5s/L20-5E	d1, d2, d6, d12, d13, d14, d15, d28, d29, d30
	L12-3RCs/L12-3VNs/L15-3RCs	d12, d28
	/L15-3WE/L15-3WU/L24-6RCs/L24-6Hs/HS24-6LU/LM18-5WU/LM24-6WU	d28, d29
	L15-3Ws	/
	L14-5sp/HS14-5Lm/L14-5WU/L14-5WE/L14-5Ws	d1, d2, d6, d12, d13, d14, d15, d30
	L30-8U/L33-8U/L33-8s	d2
L9-3PAU	/	
Phased	P4-2/P4-2s/P4-2E/P4-2NE/P4-2Ns/P10-4E/P10-4s/P10-4U/P10-4/2P2/2P2s/2P2P/P4-2m/P10-4m	d1, d2, d3, d4, d5, d6, d7, d8, d9, d10, d11, d12, d13, d14, d15, d26, d27, d28, d29, d30
	P7-3/P7-3s/P7-3E/P7-3U/P7-3P	d1, d2, d11, d13, d16, d20, d25
	P12-4/P12-4s	d1, d2, d3, d4, d5, d27
	SP5-1U/SP5-1s/SP5-1E/SP5-1/SP5-1Ns/SP5-1N/SP5-1m	d1, d4, d5, d6, d7, d8, d9, d10, d11, d12, d26, d29, d30
	LFP5-1s/LFP5-1U/LFC5-1s/LFC5-1U	d12, d29
	P8-2s/P8-2/P8-2U/P8-2P/SP9-2U/SP9-2s/SPM6-1U/XP5-1U/P8-2m	d1, d3, d4, d5, d6, d7, d8, d9, d10, d11, d12, d15, d26, d27, d28, d29, d30
Endo-cavity	65EC10EA/65EC10EB/65EC10EC	d1, d2, d3, d4, d5, d6, d12, d13, d14, d15, d27, d28, d30
	V10-4/V10-4s/V10-4B/V10-4Bs/V10-4BP/6CV1/6CV1s/6CV1P/V10-4m/V10-4m-B/65EC10ED	d1, d2, d4, d5, d6, d7, d8, d9, d10, d11, d12, d13, d14, d15, d26, d28, d29, d30
	V11-3/V11-3BE/V11-3B/V11-3WE/V11-3Ws/V11-3E/V11-3m/V11-3m-B	d1, d2, d3, d4, d5, d6, d10, d11, d12, d13, d14, d15, d26, d27, d29, d30

d1: CIDEX OPA	d16: Cidexplus
d2: Cidex Activated Dialdehyde Solution	d17: Gigasept Instru AF
d3: Minncare Cold Sterilant	d18: Osvan
d4: Ster-Bac	d19: Neojodin
d5: Triacid-N	d20: Milton Sterilising Fluid
d6: Revital-Ox Resert High Level Disinfectant	d21: hibitane
d7: gigasept PAA concentrate	d22: Sterihyde
d8: DESCOTON EXTRA	d23: MetriCide 14
d9: Gigasept FF (neu)	d24: Sekusept PLUS
d10: ANIOXYDE 1000	d25: Wavicide-01
d11: SALVANIOS pH10	d26: SALVANIOS pH7
d12: CaviCide Liquid	d27: Minncare liquid disinfectant
d13: MetriCide	d28: Virusolve+Concentrate
d14: MetriCide 28	d29: Virex II 256
d15: MetriCide OPA Plus	d30: UltrOx High-Level disinfectant

Probe		Solutions
Endo-cavity	V11-3s	d1, d2, d3, d4, d5, d6, d10, d11, d12, d13, d14, d15, d26, d27, d29, d30
	V11-3HU/V11-3HE/V11-3Hs/V11-3H/V11-3HB/SV10-2U/V10-2U	d1, d3, d4, d5, d6, d7, d8, d9, d10, d11, d12, d15, d26, d27, d28, d29, d30
	V11-3HBs/SV10-2s/V10-2s	d1, d3, d4, d5, d6, d7, d8, d9, d10, d11, d12, d15, d26, d27, d28, d29, d30
	V11-3Hs (black-white connector)	d1, d3, d4, d5, d6, d7, d8, d9, d10, d11, d12, d15, d26, d27, d28, d29, d30
	6CV1s (black-white connector)	d1, d2, d4, d5, d6, d7, d8, d9, d10, d11, d12, d13, d14, d15, d26, d28, d29, d30
Pencil	CW2s/CW5s/CW5	d1, d2, d4, d5
Biplane	CB10-4/CB10-4P/CB10-4E/CB10-4s	d1, d2, d3, d4, d5, d6, d12, d13, d14, d15, d27, d28, d30
	6LB7/6LB7s/6LB7P/6LB7E/65EB10EA	d1, d2, d3, d4, d5, d6, d12, d13, d14, d15, d27, d28, d30
	ELC13-4U/ELC10-4	d1, d12, d15, d28
	ELC13-4s	d1, d12, d15, d28
4D	4CD4/4CD4s/D6-2E	d1, d2, d4
	D7-2/D7-2E/D7-2s/SD8-1E/SD8-1s/SD8-1/SD8-1U/D6-2/D6-2P/D6-2EA/D6-2B/D6-2A/D7-2m/D6-2m/SDM9-2U	d1, d2, d3, d4, d5, d6, d10, d11, d12, d13, d14, d15, d26, d27, d28, d30
	D6-2NE/DL14-3U	d1, d18, d19, d20, d21, d22
	D8-2E/D8-2U	d1, d2, d9
	D8-4U	d1, d2, d16, d17
	DE10-3/DE10-3E/DE10-3U/DE10-3s (gray strain relief)	d1, d2, d16, d17
	DE11-3s/DE11-3E/DE11-3/DE11-3WE/DE11-3Ws/SDE14-3LU/DE13-5WU/SDE10-2WU/SDE10-2Ws	d1, d3, d4, d5, d6, d7, d8, d9, d10, d11, d12, d15, d26, d27, d30
	DE10-3WU/DE10-3WE (gray strain relief)	d1, d2, d15, d16, d17, d23, d24, d25
	DE10-3Ws/DE10-3WU/DE10-3WE/DE10-3U (white strain relief)	d1
Ocular	A10e	d1
Composite Probe	i5M/z5M/z5Ms/z5Mt/e5M/e5Ms/e5Mt/a5Mx	d1, d4, d5, d6, d7, d10, d11, d12, d15, d26, d28, d30

A.2.4 Devices

- e1: Trophon EPR/Trophon2 (Used with Trophon Sonex-HL/Trophon NanoNebulant)
 e2: Germitec UV-C
 e3: V-PRO Low Temperature Sterilization System (Used with Vaporized Hydrogen Peroxide)
 e4: STERRAD system
 e5: Lumicare ONE

	Probe	Devices
Convex	C5-1s/C5-1E/C5-1U/C5-1/C5-2/C5-2s/C5-2E/C6-2/C6-2s/C6-2P/C11-3E/C11-3s/C11-3U/C11-3/C5-1m/mC5-2m/mC11-3m/35C20EA/3C5A/SC6-1U/SC6-1E/SC6-1s/SC5-1NE/SC5-1Ns/SC5-1N	e1, e2
	C6-2Gs/C6-2GE/C6-2GU/SC7-1U/SC7-1s/SC9-2U/SC9-2s/SCM7-1U/SC6-1MU/SCM4-1U/SC6-1GU/C6-1/C6-1m/C5-2m/C5-2m-e/mSC6-1s	e1, e2
	C7-3E/C7-3/C3C1/3C1s/6C2/6C2P/6C2s/35C50EA/35C50EB/35C50P/65C15EAV/65C15EA	e1, e2
	3C5s/3C5P	e1, e2
	SC5-1U/SC5-1E	e1, e2
	SC8-2U/SC8-2s	e1
	C4-1/C4-1U/C4-1s	e1, e2
	C9-3Ts	e1, e4
SC10-2RCs	e1, e2	
Linear	L7-3/L7-3s/L7-3E/7L4s/7L4A/7L4P/7L4B/7L4Bs/7L4BP/7L5/7L5P/7L5s/7L6/7L6s/75L38EA/75L38EB/75L53EA/75L60EA/75L38P/10L4/10L4s	e1, e2
	65EL60EA/6LE7/6LE7s/6LE7P/6LE5V/6LE5Vs/6LE5VP/7LT4/7LT4s/7LT4P/7LT4E/50L60EAV/75L50EAV/75LT38EA	e1, e2, e3
	7LT4s (black-white connector)	e1, e2, e3, e4
	L10-3E/L10-3s	e1
	L9-3/L9-3U/L9-3E/L9-3s/L12-3/L12-3E/L13-3s/L13-3/L12-4/L12-4s/L14-6N/L14-6Ns/L14-6NP/L14-6NE/L14-6WE/L14-6Ws/L14-6WU/L13-3m/L18-6m/L9-3m	e1, e2
	L12-3m/L12-3m-e/L12-3Wm	e1, e2
	L11-3U/L11-3VNs/L13-3N/L13-3Ns/L14-3s/L14-3WU/L14-3WE/L14-3Ws/L14-3W/L14-3m/SL10-3U/SL10-3s/SLM10-3U	e1, e2
	L11-4/L11-4s/L14-6/L14-6s/L14-6P/10L24EA/LM14-6E/LM14-6s/LM16-4U	e1, e2
	L16-4HE/L16-4Hs/L16-4HU	/
	L16-4Hs (black-white connector)	e4
	L20-5U/L20-5s/L20-5E	e1
	L12-3RCs/L12-3VNs/L15-3RCs	e1, e2
	L15-3WE/L15-3WU/L24-6RCs/L24-6Hs/HS24-6LU/LM18-5WU/LM24-6WU	e1
	L15-3Ws	/
	L14-5sp/HS14-5Lm/L14-5WU/L14-5WE/L14-5Ws	e1, e2
	L30-8U/L33-8U/L33-8s	/
L9-3PAU	/	

- e1: Trophon EPR/Trophon2 (Used with Trophon Sonex-HL/Trophon NanoNebulant)
- e2: Germitec UV-C
- e3: V-PRO Low Temperature Sterilization System (Used with Vaporized Hydrogen Peroxide)
- e4: STERRAD system
- e5: Lumicare ONE

Probe		Devices
Phased	P4-2/P4-2s/P4-2E/P4-2NE/P4-2Ns/P10-4E/P10-4s/ P10-4U/P10-4/2P2/2P2s/2P2P/P4-2m/P10-4m	e1, e2
	P7-3/P7-3s/P7-3E/P7-3U/P7-3P	e1
	P12-4/P12-4s	e1
	SP5-1U/SP5-1s/SP5-1E/SP5-1/SP5-1Ns/SP5-1N/SP5-1m	e1, e2
	LFP5-1s/LFP5-1U/LFC5-1s/LFC5-1U	/
	P8-2s/P8-2/P8-2U/P8-2P/SP9-2U/SP9-2s/ SPM6-1U/XP5-1U/P8-2m	e1, e2
Endo-cavity	65EC10EA/65EC10EB/65EC10EC	e1, e2, e3
	V10-4/V10-4s/V10-4B/V10-4Bs/V10-4BP/6CV1/6CV1s/6CV1P/ V10-4m/V10-4m-B/65EC10ED	e1, e2, e3
	V11-3/V11-3BE/V11-3B/V11-3WE/V11-3Ws/V11-3E/V11-3m/V11-3m-B	e1, e2, e3
	V11-3s	e1, e2, e3, e4
	V11-3HU/V11-3HE/V11-3Hs/V11-3HV/V11-3HB/SV10-2U/V10-2U	e1, e2, e5
	V11-3HBs/SV10-2s/V10-2s	e1, e2, e4, e5
	V11-3Hs (black-white connector)	e1, e2, e3, e4
6CV1s (black-white connector)	e1, e2, e3, e4	
Pencil	CW2s/CW5s/CW5	/
Biplane	CB10-4/CB10-4P/CB10-4E/CB10-4s	e1, e2, e3
	6LB7/6LB7s/6LB7P/6LB7E/65EB10EA	e2, e3
	ELC13-4U/ELC10-4	/
	ELC13-4s	e4
4D	4CD4/4CD4s/D6-2E	/
	D7-2/D7-2E/D7-2s/SD8-1E/SD8-1s/SD8-1/SD8-1U/D6-2/ D6-2P/D6-2EA/D6-2B/D6-2A/D7-2m/D6-2m/SDM9-2U	e1
	D6-2NE/DL14-3U	e1
	D8-2E/D8-2U	e1
	D8-4U	/
	DE10-3/DE10-3E/DE10-3U/DE10-3s (gray strain relief)	e1, e2
	DE11-3s/DE11-3E/DE11-3/DE11-3WE/DE11-3Ws/ SDE14-3LU/DE13-5WU/SDE10-2WU/SDE10-2Ws	e1, e3
	DE10-3WU/DE10-3WE (gray strain relief)	e1, e2
	DE10-3Ws/DE10-3WU/DE10-3WE/DE10-3U (white strain relief)	e1
Ocular	A10e	/
Composite Probe	i5M/z5M/z5Ms/z5Mt/e5M/e5Ms/e5Mt/a5Mx	e1

NOTE:

For V-PRO Low Temperature Sterilization System:

- The probe should be placed into a STERIS Sterilization Tray and wrapped with sterilization wrap. In Canada/FDA region, the STERIS Sterilization Tray and sterilization wrap should be cleared by the FDA/HC, such as H600 OneStep® sterilization wrap.
- Start the sterilization system using the Non Lumen Cycle according to the instructions provided by the sterilization system manufacturer.

A.2.5 Powders

f1: Rely+On PeraSafe

Probe		Powders
4D	D8-2E/D8-2U	f1
	D8-4U	f1
	DE10-3/DE10-3E/DE10-3U/DE10-3s (gray strain relief)	f1
	DE10-3WU/DE10-3WE (gray strain relief)	f1

This page intentionally left blank.

Appendix B Composition

B.1 Active Ingredients of the Cleaner

Cleaner	Active Ingredients
MetriZyme/MetriSponge	Proteinase subtilisin
Revital-OX Enzymatic Detergent	Citric acid, Triethanolamine, Ethanolamine, Ethoxylated coconut oil alkyl amine, Subtilisins (proteolytic enzymes), Glycerine
Endozime and Endozime Sponge	Subtilisins (proteolytic enzymes)
Prolystica 2X Concentrate Enzymatic Cleaner/klenzyme/Liquinox/Tristel Pre-Clean Wipes	enzymatic detergent
ANIOSYME 5	ionic surfactants, sequestering agent, stabilising agent, enzymatic complex, Excipients
DDN9	N PROPIONATE, N-DIDECYL—N-METHYL-POLY{OXYETHYL}AMMONIUM TETRAPOTASSIUM ETHYLENEDIAMINETETRAACETATE EDETIC ACID
Reynard Neutral detergent wipes	non-ionic surfactants, cationic surfactant, humectant

B.2 Active Ingredients of the Disinfectant

Disinfectant	Active Ingredients
Tristel Trio Wipes/Tristel Jet/Tristel DUO/Tristel DUO ULT/Tristel DUO NCU/Tristel Sporicidal Wipes	chlorine dioxide
IODOCLEAN	sodium thiosulfate and excipients
Ster-Bac/PI-SPRAY II/mikrozid [®] Sensitive Wipes/Clinell Universal Wipes/Sani-Cloth HB/Sani-Cloth Active/T-Spray/Mikorbac Tissues/Sani-Cloth Germicidal Wipes/SALVANIOS pH7/SALVANIOS pH10/protex [™] ultra disinfectant wipes/CaviWipes XL/CAVICIDE 1	Quaternary Ammoniums
Tristel Rinse Wipes	deionized water
Cidex OPA	0.55% Ortho-phthlaldehyde
DESCOTON extra/Wavicide-01	glutaraldehyde

Disinfectant	Active Ingredients
Oxivir™/MC Tb	0.5% hydrogen peroxide
CaviWipes	isopropanol, ethylene glycol monobutyl ether (2-butoxyethanol), diisobutylphenoxyethoxyethyl dimethyl benzyl ammonium chloride, water
CaviWipes 1	isopropanol, ethanol, ethylene glycol monobutyl ether (2-butoxyethanol), didecyl-dimethyl-ammonium chloride, water
Dispatch Towels	Sodium hydroxide, Sodium metasilicate, Sodium hypochlorite
SONOTM ULTRASOUND WIPES	octyl decyl dimethyl ammonium chloride; dioctyl dimethyl ammonium chloride; didecyl dimethyl ammonium chloride; dimethyl benzyl ammonium chloride
Minnicare® Cold Sterilant/Minnicare liquid disinfectant	22% Hydrogen Peroxide, 4.5% Peroxyacetic Acid
mikrozid® AF Wipes Jumbo	25% ethanol; 35% propan-1-ol
CLEANISEPT® WIPES	0.25g Quaternary Ammoniums
Wip'Anios premium	Quaternary Ammoniums
Cidex Activated Dialdehyde Solution	glutaraldehyde
TRANSEPTIC	isopropyl alcohol, chlorhexidine gluconate
Protex Spray	Quaternary ammonium compounds di-C8-10-alkyldimethyl, chlorides Water
Sani-HyPerCide GERMICIDAL SPRAY	hydrogen
Sani-24 GERMICIDAL SPRAY	Quaternary Ammoniums, Ethanol
Sani-Cloth® Prime GERMICIDAL DISPOSABLE WIPE/Sani-Cloth® Plus	Quaternary Ammoniums
STERRAD® system	Hydrogen peroxide plasma
gigasept® FF(neu)	0.11g succindialdehyde; 0.3g dimethoxytetrahydrofuran; < 5% anionic surfactant; non-ionic surfactants; anti-corrosion compounds; fragrance
gigasept® PAA concentrate	peracetic acid (5%); hydrogen peroxide: acetic acid; potassium hydroxide: corrosion inhibitor
Protex™ Disinfectant Spray/Protex™ Disinfectant Wipes	octyl decyl dimethyl ammonium chloride; dioctyl dimethyl ammonium chloride; didecyl dimethyl ammonium chloride; dimethyl benzyl ammonium chloride
Triacid-N	N-Dodecylpropan-1,3-diamin; propan-2-ol; isotridecanol, ethoxylated; non-ionic detergent
Surfa'safe	Quaternary Ammoniums

Disinfectant	Active Ingredients
Revital-Ox [®] Resert [®] High Level Disinfectant/UltrOx [™] High-Level disinfectant/Trophon Sonex-HL/Trophon NanoNebulant	Hydrogen peroxide
ANIOXYDE 1000	3% Hydrogen Peroxide
Sani-Cloth AF3	Quaternary ammonium chlorides.
Metricide OPA Plus	Ortho-phthlaldehyde
Metricide/Metricide 14/Metricide 28/Cidex Plus/Sterihyde	Glutaraldehyde
CaviCide	isopropanol, ethanol, ethylene glycol monobutyl ether (2-butoxyethanol), diisobutylphe-noxyethoxyethyl dimethyl benzyl ammonium chloride, water
Gigasept AF	didecyldimethylammonium chloride, glycine, aminoalkyl derivs tridecylpolyethylenglycoether.
Rely+On PeraSafe	disodium carbonate, citric acid
Sonogel	carbomer, polyacrylat
Osvan:	Ammonia benzalkonium
Neojodin	povidone-iodine
Milton	sodium hypochlorite
Hibitane	Hlorhexidine
WIP'ANIOS CLEAN'UP	Association of surfactants, excipients
OXIVIR 1/Oxivir [®] Tb Wipes/Oxivir 1 Wipes/Accel TB Liquid/Accel TB Wipes	Hydrogen peroxide
WIP'ANIOS SPOR'ACTIV	Hydrogen peroxide and peroxyacetic acid mixture stabilized
SANI-CLOTH [®] BLEACH GERMICIDAL DISPOSABLE WIPE	Sodium hypochlorite
wip anios excel	Quaternary Ammoniums, non-ionic surfactants, sequestering agent, excipients
Virusolve [®] + Pronte all'uso Wipes	Polycarboxylate, non ionic emulsifier, alcohol, Quaternary Ammoniums
Virusolve [®] + Concentrate	2-Aminoethanol, Didecyldimethyl ammonium Chloride, Propan-2-ol, Potassium Carbonate
Super Sani-Cloth [®] /Virex II 256	Quaternary Ammoniums
Reynard Premier detergent & disinfectant wipes	non-ionic surfactants, three cationic biocides
Gelica Surface Disinfecting Towelettes	Compound quaternary ammonium salt disinfectant
Incidin OxyWipe S	Hydrogen peroxide
Kohrsolin FF Tissues	Quaternary Ammoniums
Bacillol 30 Tissues	Ethanol, Propan-2-ol, Propan-1-ol, Quaternary Ammoniums

Composition

Disinfectant	Active Ingredients
MATRIX WIPES	/
Meliseptol Wipes ultra	Quaternary Ammoniums
CLEANISEPT WIPES FPRTE MAXI	Quaternary Ammoniums

Appendix C Registered Disinfectants in Canada

Drug Identification Number /License Number	Name
74736	V-PRO Low Temperature Sterilization System
2981	STERRAD system
02286467	Revital-Ox Resert High Level Disinfectant
100935	Trophon EPR/Trophon2
01963996	MetriCide
01964461	MetriCide 28
02197170	Wavicide-01
02277484	Minnicare liquid disinfectant
02161656	CaviCide Liquid
02247354	Super Sani-Cloth Germicidal Disposable Wipe
02517000	Sani-Cloth Prime Germicidal Disposable Wipe

This page intentionally left blank.

Appendix D Registered Disinfectants in FDA Region

Registration Number	Name	Microbicidal Method	
FDA 510(k)	K190103	V-PRO Low Temperature Sterilization System	Sterilization
	K924434	Cidex Activated Dialdehyde Solution	High-level disinfectant and Sterilization
	K030004	CIDEX OPA	High-level disinfectant
	K923744	Cidexplus	High-level disinfectant and Sterilization
	K080420	Revital-Ox Resert High Level Disinfectant	High-level disinfectant
	K091022	UltrOx High-Level disinfectant	High-level disinfectant
	K103059	Trophon EPR	High-level disinfectant
	K173865	Trophon2	High-level disinfectant
	K930284	MetriCide	High-level disinfectant and Sterilization
	K931052	MetriCide 28	High-level disinfectant and Sterilization
	K140703	MetriCide OPA Plus	High-level disinfectant
	K914749	Wavicide-01	High-level disinfectant and Sterilization
	K954142	STERRAD system	Sterilization

Registration Number	Name	Microbicidal Method	
EPA	9480-6	Sani-Cloth Plus Germicidal Disposable Cloth	Low-level disinfectant
	70627-56	Oxivir Tb	Low-level disinfectant
	9480-9	Sani-Cloth AF3 Germicidal Disposable Wipe	Low-level disinfectant
	46781-8	CaviWipes	Low-level disinfectant
	46781-6	CaviCide	Low-level disinfectant
	70627-60	Oxivir Tb Wipes	Low-level disinfectant
	46781-12	CaviCide 1	Low-level disinfectant
	9480-4	Super Sani-Cloth Germicidal Disposable Wipe	Low-level disinfectant
	9480-12	Sani-Cloth Prime Germicidal Disposable Wipe	Low-level disinfectant
	9480-14	Sani-HyPerCide GERMICIDAL SPRAY	Low-level disinfectant
	42182-9- 9480	Sani-24 GERMICIDAL SPRAY	Low-level disinfectant
	9480-8	Sani-Cloth Bleach Germicidal Disposable Wipe	Low-level disinfectant
	70627-24	Virex II 256	Low-level disinfectant

