

**iMEC15S/iMEC15/iMEC12  
iMEC10/iMEC8/iMEC7  
iMEC6/iMEC5**

**Patient Monitor**

**Service Manual**



# Intellectual Property Statement

SHENZHEN MINDRAY BIO-MEDICAL ELECTRONICS CO., LTD. (hereinafter called Mindray) owns the intellectual property rights to this product and this manual. This manual may refer to information protected by copyrights or patents and does not convey any license under the patent rights of Mindray, nor the rights of others. Mindray does not assume any liability arising out of any infringements of patents or other rights of third parties.

Mindray intends to maintain the contents of this manual as confidential information. Disclosure of the information in this manual in any manner whatsoever without the written permission of Mindray is strictly forbidden. Release, amendment, reproduction, distribution, rent, adaptation and translation of this manual in any manner whatsoever without the written permission of Mindray is strictly forbidden.

**mindray**,  **MINDRAY**, and **MINDRAY** are the registered trademarks or trademarks owned by Mindray in China and other countries. All other trademarks that appear in this manual are used only for editorial purposes without the intention of improperly using them. They are the property of their respective owners.

Contents of this manual are subject to changes without prior notice.

## Revision History

This manual has a revision number. This revision number changes whenever the manual is updated due to software or technical specification change. Contents of this manual are subject to change without prior notice.

- Revision number: 6.0
- Release time: May 2017

© 2011 - 2017 Shenzhen Mindray Bio-Medical Electronics Co., Ltd. All rights reserved.

# Preface

## Manual Purpose

This manual provides detailed information about the assembling, disassembling, testing and troubleshooting of the equipment to support effective troubleshooting and repair. It is not intended to be a comprehensive, in-depth explanation of the product architecture or technical implementation. Observance of the manual is a prerequisite for proper equipment maintenance and prevents equipment damage and personnel injury.

This manual is based on the maximum configuration; therefore, some contents may not apply to your monitor. If you have any question, please contact our Customer Service Department.

## Intended Audience

This manual is for biomedical engineers, authorized technicians or service representatives responsible for troubleshooting, repairing and maintaining the patient monitors.

## Abbreviations

Abbreviations used in this manual are:

CMS	central monitoring system
PCB	printed circuit board

## Passwords

A password may be required to access different modes within the monitor. The passwords are listed below:

- User maintenance: 888888 (User adjustable)
- Factory maintenance: 332888
- Demo mode: 2088
- Configuration mode: 315666 (User adjustable)

# Table of Contents

- 1 Safety.....1-1**
  - 1.1 Safety Information.....1-1
    - 1.1.1 Dangers.....1-2
    - 1.1.2 Warnings.....1-2
    - 1.1.3 Cautions.....1-2
    - 1.1.4 Notes.....1-2
  - 1.2 Equipment Symbols.....1-3
  
- 2 Theory of Operation.....2-1**
  - 2.1 Introduction.....2-1
  - 2.2 System Connections.....2-2
    - 2.2.1 Installation Support.....2-2
    - 2.2.2 Connectors for Peripheral Devices .....2-3
  - 2.3 Main Unit.....2-4
  - 2.4 Front Housing Assembly .....2-5
    - 2.4.1 Main Board .....2-5
    - 2.4.2 Keypad and the Navigation Knob.....2-6
    - 2.4.3 Power On/Off and LED Indicator Board.....2-7
    - 2.4.4 Alarm Lamp Board.....2-7
    - 2.4.5 Display.....2-7
    - 2.4.6 Touchscreen and Touchscreen Control Board.....2-7
  - 2.5 Rear Housing Assembly.....2-7
    - 2.5.1 AC/DC Power Board.....2-8
    - 2.5.2 Interface Board (DC/DC, Power Management Circuit) .....2-8
    - 2.5.3 Battery Back Board.....2-9
    - 2.5.4 Parameter Module .....2-10
    - 2.5.5 Multi-parameter Module .....2-10
    - 2.5.6 SpO<sub>2</sub> Board .....2-11
    - 2.5.7 C.O. Module.....2-11
    - 2.5.8 CO<sub>2</sub> Module.....2-11
    - 2.5.9 Recorder.....2-12
  - 2.6 Speaker .....2-12
  
- 3 Unpacking and Installation.....3-1**
  - 3.1 Unpacking the Equipment .....3-1
  - 3.2 Preparation for Installation.....3-2
    - 3.2.1 Preparation for Installation Site.....3-2
    - 3.2.2 Electrical Requirements .....3-3
    - 3.2.3 Monitor Installation.....3-3
    - 3.2.4 Preparation for Power on.....3-3
  
- 4 Hardware and Software Upgrade.....4-1**

4.1 Introduction.....	4-1
4.2 Hardware Upgrade.....	4-1
4.2.1 Upgrading the 1G SD Storage Card.....	4-1
4.2.2 Upgrading Touchscreen.....	4-2
4.2.3 Upgrading Wi-Fi.....	4-3
4.2.4 Upgrading Recorder.....	4-4
4.2.5 Upgrading CO <sub>2</sub> .....	4-5
4.2.6 Upgrading C.O.....	4-8
4.2.7 Upgrading IBP.....	4-9
4.2.8 Upgrading VGA/USB/Multi-functional Interface.....	4-9
4.3 Software Upgrade.....	4-11
4.3.1 Installing Mindray Patient Monitor Software Upgrade Tool (PN: G-110-000493-00).....	4-11
4.3.2 Software Upgrade Procedure.....	4-13
<b>5 Testing and Maintenance.....</b>	<b>5-1</b>
5.1 Introduction.....	5-1
5.1.1 Test Equipment.....	5-1
5.1.2 Test Report.....	5-1
5.1.3 Preventative Maintenance.....	5-1
5.1.4 Recommended Frequency.....	5-2
5.2 Visual Inspection.....	5-3
5.3 Power-on Test.....	5-3
5.4 Module Performance Tests.....	5-3
5.4.1 ECG Test and Calibration.....	5-3
5.4.2 Resp Test.....	5-4
5.4.3 SpO <sub>2</sub> Test.....	5-4
5.4.4 NIBP Test.....	5-5
5.4.5 Temp Test.....	5-7
5.4.6 IBP Test and Calibration.....	5-7
5.4.7 C.O. Test.....	5-9
5.4.8 Mainstream CO <sub>2</sub> Tests.....	5-9
5.4.9 Sidestream and Microstream CO <sub>2</sub> Tests and Calibration.....	5-10
5.4.10 AG Tests.....	5-12
5.5 Nurse Call Function Test.....	5-15
5.6 Analog Output Performance Test.....	5-16
5.7 Electric Safety Tests.....	5-16
5.8 Touchscreen calibration.....	5-16
5.9 Recorder check.....	5-16
5.10 Battery Check.....	5-17
5.11 Factory Maintenance.....	5-17
5.11.1 Accessing Factory Maintenance Menu.....	5-17
5.11.2 Drawing Waves.....	5-18
5.11.3 Recorder.....	5-18
5.11.4 Software Version.....	5-18
5.11.5 Monitor information recording.....	5-19

<b>6 Corrective Action.....</b>	<b>6-1</b>
6.1 Introduction.....	6-1
6.2 Part Replacement.....	6-1
6.3 Checking Patient Monitor Status.....	6-1
6.4 Checking Software Version.....	6-1
6.5 Checking Technical Alarms.....	6-2
6.6 Troubleshooting Guide.....	6-2
6.6.1 Power On/Off Failure.....	6-2
6.6.2 Display Failures.....	6-2
6.6.3 Alarm Lamp Failures.....	6-3
6.6.4 Button and Knob Failures.....	6-3
6.6.5 Sound Failures.....	6-4
6.6.6 Power Supply Failures.....	6-4
6.6.7 Recorder Failures.....	6-5
6.6.8 Output Interface Failure.....	6-5
6.6.9 SD Card Failure.....	6-6
6.6.10 Wired Network Related Problems.....	6-6
6.6.11 Wi-Fi Related Problems.....	6-7
6.6.12 Software Upgrade Problems.....	6-7
6.6.13 Technical Alarm Messages.....	6-7
<b>7 Disassembly and Repair.....</b>	<b>7-1</b>
7.1 Tools Required.....	7-1
7.2 Preparations for Disassembly.....	7-1
7.3 Disassembling the Main Unit.....	7-2
7.3.1 Separating the Front and Rear Half of the Monitor.....	7-2
7.3.2 Removing the Parameter Connector Panel Assembly.....	7-3
7.3.3 Disassembling the Parameter Module Assembly.....	7-3
7.3.4 Removing the Battery Compartment Assembly.....	7-6
7.3.5 Removing the Power Management and Interface Board.....	7-6
7.3.6 Removing the Recorder (Optional).....	7-7
7.3.7 Checking Waterproof Strips before Reassembling.....	7-7
7.4 Disassembling the Front Housing Assembly.....	7-8
7.4.1 Removing Touchscreen Control Board (Optional).....	7-8
7.4.2 Removing Antenna (Optional).....	7-9
7.4.3 Removing SD Card (Optional).....	7-9
7.4.4 Removing the Main Board.....	7-10
7.4.5 Removing the Touchscreen (Optional).....	7-11
7.4.6 Disassembling the Screen.....	7-11
7.4.7 Removing the Keypad.....	7-13
7.4.8 Removing the Encoder.....	7-13
7.4.9 Removing the Alarm Lamp Board.....	7-14
7.4.10 Removing the ON/OFF Key Board.....	7-14
7.5 Disassembling the Battery Compartment Assembly.....	7-14
7.5.1 Removing the Power Board.....	7-14
7.5.2 Removing the Battery Interface Board Assembly.....	7-15

7.6 Disassembling the Parameter Module Assembly .....	7-15
7.6.1 Removing the Mindray M02C CO <sub>2</sub> Module (Optional).....	7-15
7.6.2 Removing the Mainstream CO <sub>2</sub> Module (Optional).....	7-16
7.6.3 Removing the Microstream CO <sub>2</sub> module (Optional).....	7-16
7.6.4 Removing the C.O. Module (Optional).....	7-16
7.6.5 Removing the SpO <sub>2</sub> Board.....	7-17
7.6.6 Removing the Multi-parameter Module .....	7-17
7.6.7 Removing the Pump and Valve.....	7-17
7.7 Removing the Parameter Connector Assembly .....	7-18
7.7.1 Removing the Mainstream CO <sub>2</sub> Signal Cable (Optional).....	7-18
7.7.2 Removing the Microstream CO <sub>2</sub> Connector Assembly (Optional) .....	7-18
7.7.3 Removing the Watertrap Base Assembly (Optional) .....	7-19
7.7.4 Removing the Cables from the Parameter Connector Assembly.....	7-19
7.7.5 Removing the Recorder.....	7-20
<b>8 Parts.....</b>	<b>8-1</b>
8.1 Introduction.....	8-1
8.2 iMEC8/iMEC5.....	8-2
8.2.1 Main unit.....	8-2
8.2.2 Front Housing Assembly (Nakescreen).....	8-3
8.2.3 Front Housing Assembly (Touchscreen).....	8-5
8.2.4 Rear Housing (Network/VGA/USB/Analog Input & Output) .....	8-7
8.2.5 Rear Housing Assembly.....	8-9
8.2.6 Battery Compartment Assembly .....	8-10
8.2.7 Parameter module assembly .....	8-11
8.2.8 Parameter connector panel assembly.....	8-13
8.2.9 Mindray Sidestream CO <sub>2</sub> Module Kit .....	8-14
8.2.10 Ordion Microstream CO <sub>2</sub> Module Kit.....	8-15
8.2.11 Capnostat Mainstream CO <sub>2</sub> module kit.....	8-16
8.2.12 TR6F Recorder Kit .....	8-17
8.2.13 Battery charge board assembly (12 inch).....	8-17
8.3 iMEC10/iMEC6.....	8-18
8.3.1 Main unit.....	8-18
8.3.2 Front Panel Assembly (10 Inch/touchscreen/Wi-Fi+ 1G SD card).....	8-19
8.3.3 Fujitsu Touchscreen Kit (10 Inch LCD) .....	8-20
8.3.4 Front Housing Assembly (10 Inch) .....	8-21
8.3.5 Tianma LCD display kit (10 inch).....	8-23
8.3.6 Rear Housing Assembly.....	8-24
8.3.7 Rear Housing Assembly.....	8-26
8.3.8 Battery Compartment Assembly .....	8-27
8.3.9 Parameter Module Assembly.....	8-28
8.3.10 Parameter Connector Assembly.....	8-28
8.3.11 Mindray Sidestream CO <sub>2</sub> Module Kit.....	8-28
8.3.12 Oridion Microstream CO <sub>2</sub> Module Kit .....	8-28
8.3.13 Capnostat Mainstream CO <sub>2</sub> Module Kit.....	8-28
8.3.14 TR6F Recorder Kit .....	8-28



8.3.15 Battery Interface Board Assembly .....	8-28
8.4 iMEC12/iMEC7 .....	8-28
8.4.1 Main Unit .....	8-28
8.4.2 Front Panel Assembly (12 Inch/touchscreen/Wi-Fi+ 1G SD card) .....	8-29
8.4.3 Fujitsu touchscreen kit (12 Inch) .....	8-30
8.4.4 Front Housing Assembly (12 Inch).....	8-31
8.4.5 Tianma LCD Display Kit (12 Inch).....	8-33
8.4.6 Rear Housing Assembly .....	8-33
8.4.7 Rear Housing Subassembly .....	8-33
8.4.8 Battery Compartment Assembly.....	8-34
8.4.9 Parameter Module Assembly .....	8-34
8.4.10 Parameter Connector Assembly .....	8-34
8.4.11 Mindray Sidestream CO <sub>2</sub> Module Kit .....	8-34
8.4.12 Oridion Microstream CO <sub>2</sub> Module Kit.....	8-34
8.4.13 Capnostat Mainstream CO <sub>2</sub> Module Kit.....	8-34
8.4.14 TR6F Recorder Kit.....	8-34
8.4.15 Battery Interface Board Assembly.....	8-34
8.5 iMEC15/iMEC15S .....	8-35
8.5.1 Front Panel Assembly .....	8-35
8.5.2 LCD Display Kit.....	8-37
8.5.3 Touchscreen Kit.....	8-39
8.6 Other Maintainable Parts .....	8-41
<b>A Electrical Safety Inspection .....</b>	<b>A-1</b>
A.1 Power Cord Plug.....	A-1
A.2 Device Enclosure and Accessories .....	A-1
A.3 Device Labeling.....	A-2
A.4 Protective Earth Resistance.....	A-2
A.5 Earth Leakage Test.....	A-3
A.6 Patient Leakage Current.....	A-4
A.7 Mains on Applied Part Leakage.....	A-6
A.8 Patient Auxiliary Current.....	A-7
A.9 Scheduled Electrical Safety Inspection .....	A-9
A.10 Electrical Safety Inspection after Repair .....	A-10

**FOR YOUR NOTES**

# 1 Safety

---

---

## 1.1 Safety Information

---

---

### DANGER

- Indicates an imminent hazard that, if not avoided, will result in death or serious injury.
- 
- 

### WARNING

- Indicates a potential hazard or unsafe practice that, if not avoided, will result in death or serious injury.
- 
- 

### CAUTION

- Indicates a potential hazard or unsafe practice that, if not avoided, could result in minor personal injury or product/property damage.
- 
- 

### NOTE

- Provides application tips or other useful information to ensure that you get the most from your product.
- 
-

### 1.1.1 Dangers

There are no dangers that refer to the product in general. Specific “Danger” statements may be given in the respective sections of this manual.

### 1.1.2 Warnings

---

#### WARNING

---

- **All installation operations, expansions, changes, modifications and repairs of this product are conducted by Mindray authorized personnel.**
  - **There is high voltage inside the equipment. Never disassemble the equipment before it is disconnected from the AC power source or the battery.**
  - **When you disassemble/reassemble a parameter module, a patient leakage current test must be performed before it is used again for monitoring.**
  - **The equipment must be connected to a properly installed power outlet with protective earth contacts only. If the installation does not provide for a protective earth conductor, disconnect it from the power line and operate it on battery power, if possible.**
  - **Disposal of the packaging material should observe the applicable waste control regulations. and keeping it out of children’s reach.**
- 

### 1.1.3 Cautions

---

#### CAUTION

---

- **Make sure that no electromagnetic radiation interferes with the performance of the equipment when preparing to carry out performance tests. Mobile phone, X-ray equipment or MRI devices are a possible source of interference as they may emit higher levels of electromagnetic radiation.**
  - **Before connecting the receiver to the power line, check that the voltage and frequency ratings of the power line are the same as those indicated on the unit’s label or in this manual.**
  - **Protect the equipment from damage caused by drop, impact, strong vibration or other mechanical force during servicing.**
- 

### 1.1.4 Notes

#### NOTE

---

- **Refer to Operation Manual for detailed operation and other information.**
- 

## 1.2 Equipment Symbols

See the iMec series Operator’s Manual for information about the symbols used on this product and its packaging.

# 2 Theory of Operation

---

## 2.1 Introduction

This patient monitor is designed to monitor a fixed set of physiological parameters including ECG, respiration (Resp), temperature (Temp), SpO<sub>2</sub>, pulse rate (PR), non-invasive blood pressure (NIBP), invasive blood pressure (IBP), cardiac output (C.O.), and carbon dioxide (CO<sub>2</sub>).

The patient monitor also:

- Provides audible and visual alarm indications in case of patient or equipment problems.
- Enables displaying, reviewing, storing and transferring of real-time data and wave.
- Incorporates multiple input devices such as buttons, knob, and touchscreen.
- Enables program upgrade over the network.
- Integrates the information of other devices, which include but are not restricted to defibrillator.

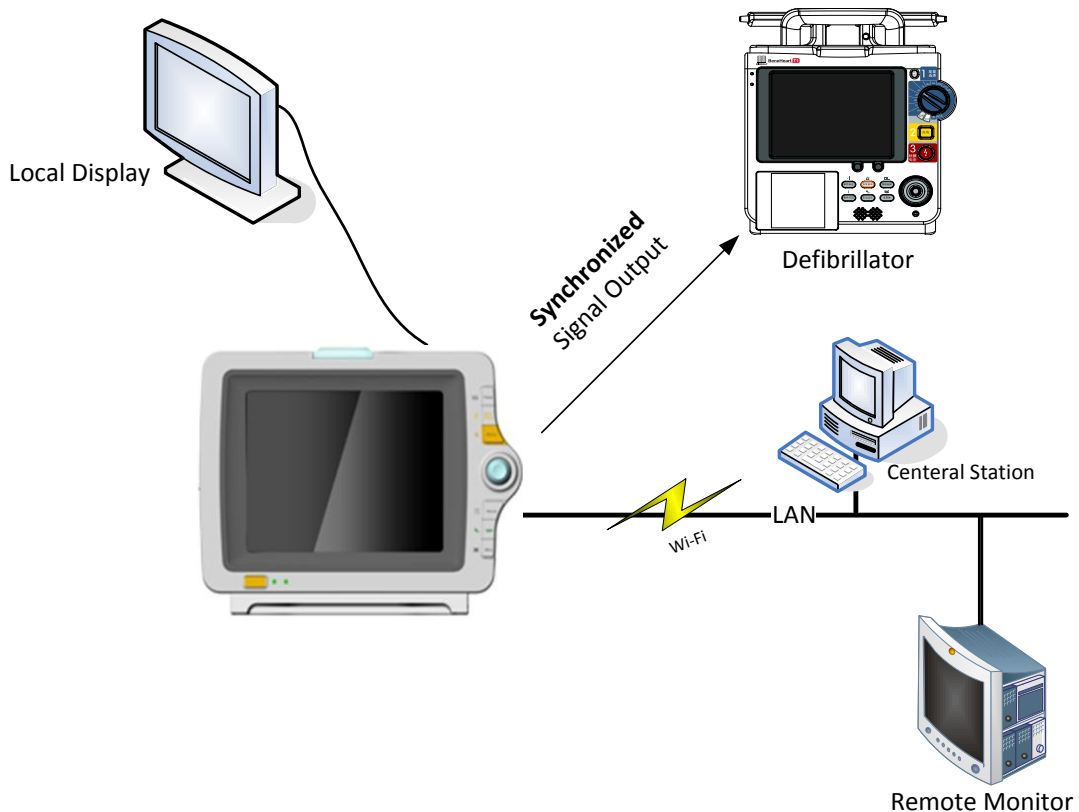

The above figure shows a system consists of the iMEC patient monitor and its peripheral devices. The iMEC patient monitor:

- Can be used for monitoring the physiological parameters, giving alarms and reviewing patient data, etc.
- Supports recorder.
- Supports nurse call signal, synchronization defibrillation signal, and analog output signal.
- Supports Wi-Fi module, wired network, remote view, and communication with the HyperVisor Central Monitoring System.
- Supports a secondary display.
- Supports external AC power source and an internal battery.
- Supports clinical data acquisition, which has two ways: by SD card and by USB drive.  
The system software should support data output function, for SD card is a built-in device.

## 2.2 System Connections

### 2.2.1 Installation Support

The patient monitor can be mounted on a wall bracket or on a trolley support. The wall bracket or trolley support can be ordered optionally. Each type of mounting bracket is delivered with a complete set of mounting hardware and instructions. Refer to the documentation delivered with the mounting hardware for instructions on assembling mounts.

---

#### CAUTION

- **Use mounting brackets we supply or approve. If other compatible mounting bracket is used, be sure it can be safely used on the patient monitor.**
  - **The mounting bracket should be installed by our qualified service personnel, or engineers who have adequate knowledge on it.**
  - **If other mounting solution is used, the installation personnel and the customer should verify if it can be safely used on the patient monitor, and the customer assume the responsibility for any risk resulting from that.**
-

## 2.2.2 Connectors for Peripheral Devices

On the back of the patient monitor you can find all connectors for peripheral devices.



Figure 1 iMEC Rear View

1. AC power input:  
used to connect an AC power source (100 to 240 VAC, 50/60 Hz).
2. Equipotential terminal:  
used to connect the equipotential terminal of other equipments, eliminating potential difference between different pieces of equipment.
3. VGA connector:  
used to connect a secondary display.
4. Network connector:  
an RJ45 connector, used to connect an Ethernet network or a PC.
5. Multifunctional connector:  
used to output analog signals and defibrillator synchronization signals.
6. General USB connector:  
used to connect any USB-compatible peripheral device.

## 2.3 Main Unit

The main unit of the patient monitor consists of two parts:

- Front housing assembly: main board, keypad board assembly (knob), display, touchscreen, alarm lamp board, power switch, and indicator board.
- Rear housing assembly: power board (AC/DC), battery pad, interface board, recorder, speaker, multi-parameter module which includes three types of SpO<sub>2</sub> stacking board, CO<sub>2</sub> module, and IBP/C.O. module.

The following figure shows the main unit architecture of the patient monitor.

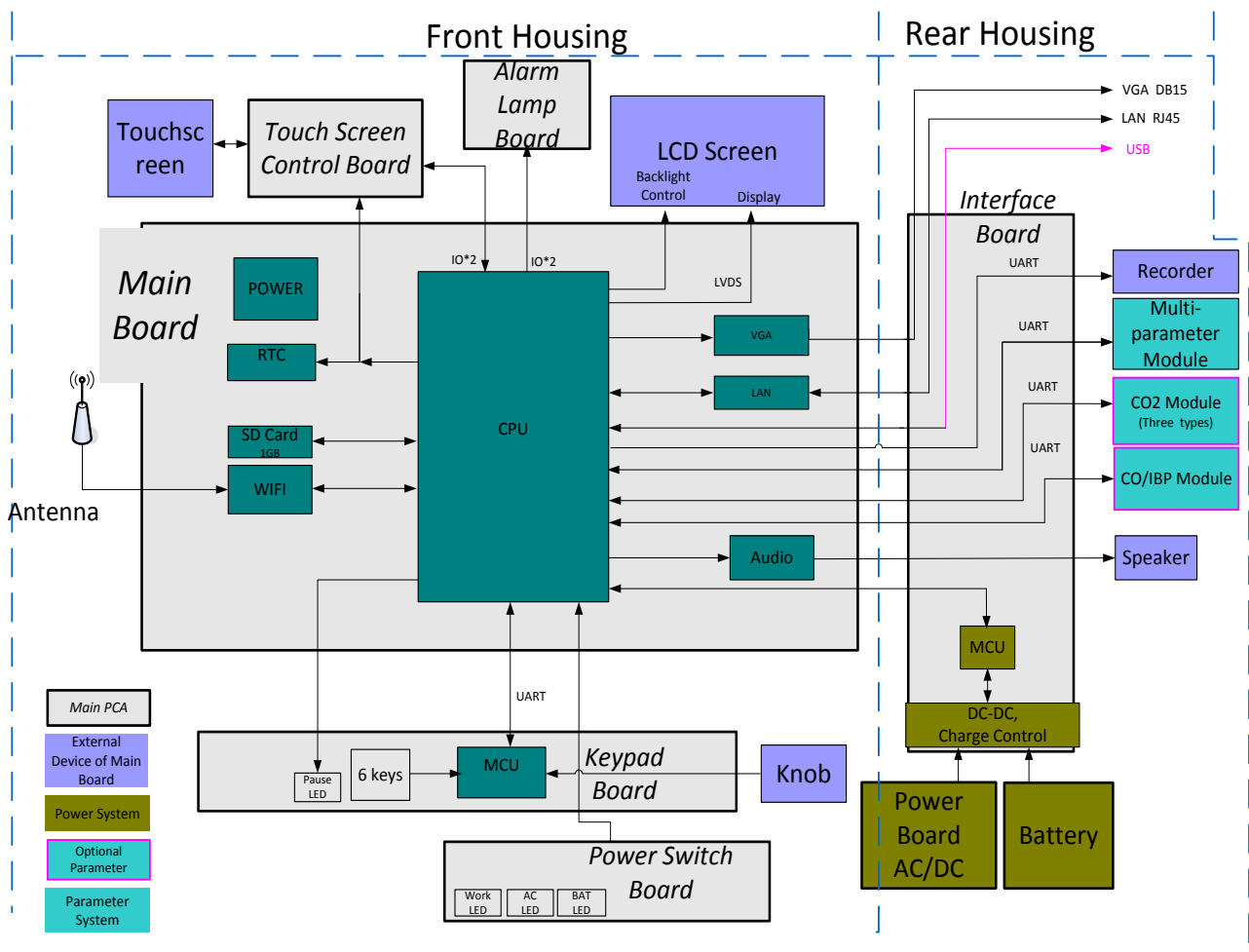



## 2.4 Front Housing Assembly

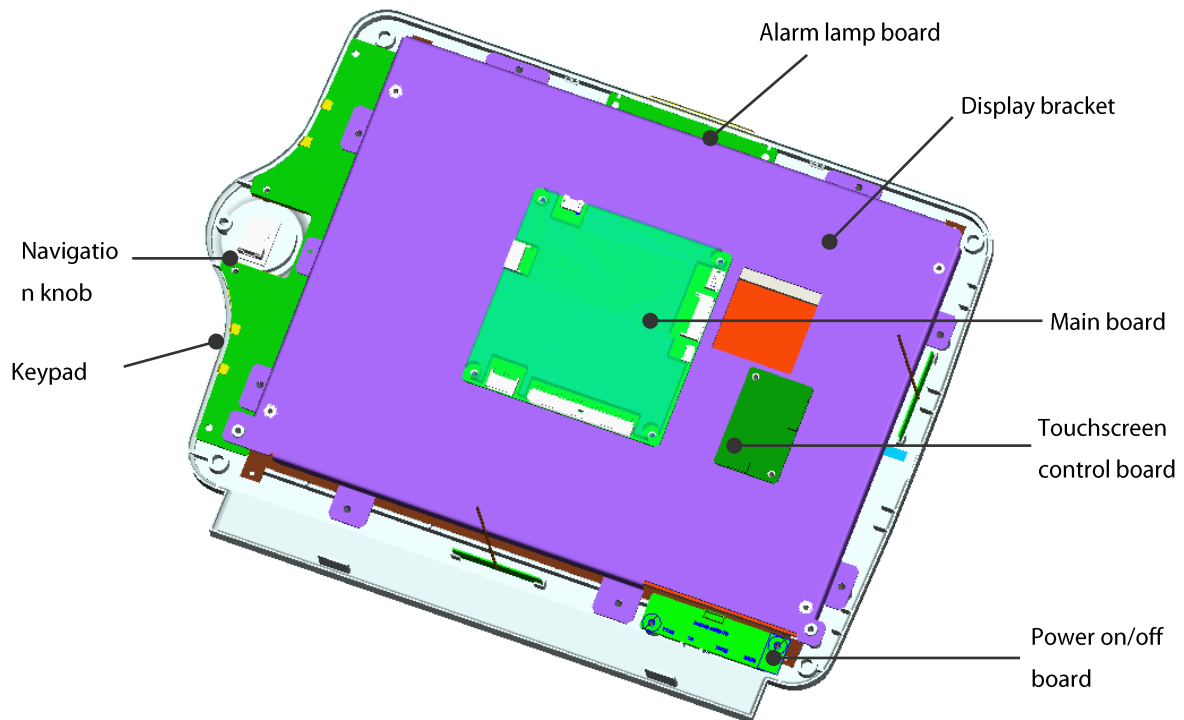

### 2.4.1 Main Board

The main board is located at the center of the front housing assembly's LCD metal sheet. It is the heart of the patient monitor. It provides communication, display, and data storage functions, including:

- Display drive and backlight control
- Wired and wireless network
- Data storage (DDR, NOR flash, and SD card)
- Printing
- Serial ports: there are 7 serial ports, respectively for multi-parameter module, C.O./IBP module, sidestream/mainstream CO2 module, recorder, power board, and key board. The seventh serial board is for future use.
- Connection with touchscreen control board
- Audio drive
- EEPROM drive
- USB

The main board has the following interfaces to connect other PCBAs:

- Display signal interface
- Backlight control interface
- Keypad interface
- Alarm lamp interface
- Wi-Fi interface
- SD storage card interface
- Interface board interface (for external output, module communication, power supply and etc.)

### 2.4.2 Keypad and the Navigation Knob

The keypad and navigation knob are located at the right side of the front housing assembly. The navigation knob can be rotated both clockwise and counterclockwise. It can also be pressed down. The navigation knob is connected with the keypad. The keypad has the following functions:

- It scans and detects the input of the six keys;
- It integrates the power on/off hardkey;
- It integrates the rotary encoder;
- It connects and forwards the status of power switch and LED board to the main board; and,
- It communicates with the main board through a serial port.

The following figure shows the connection of keypad:

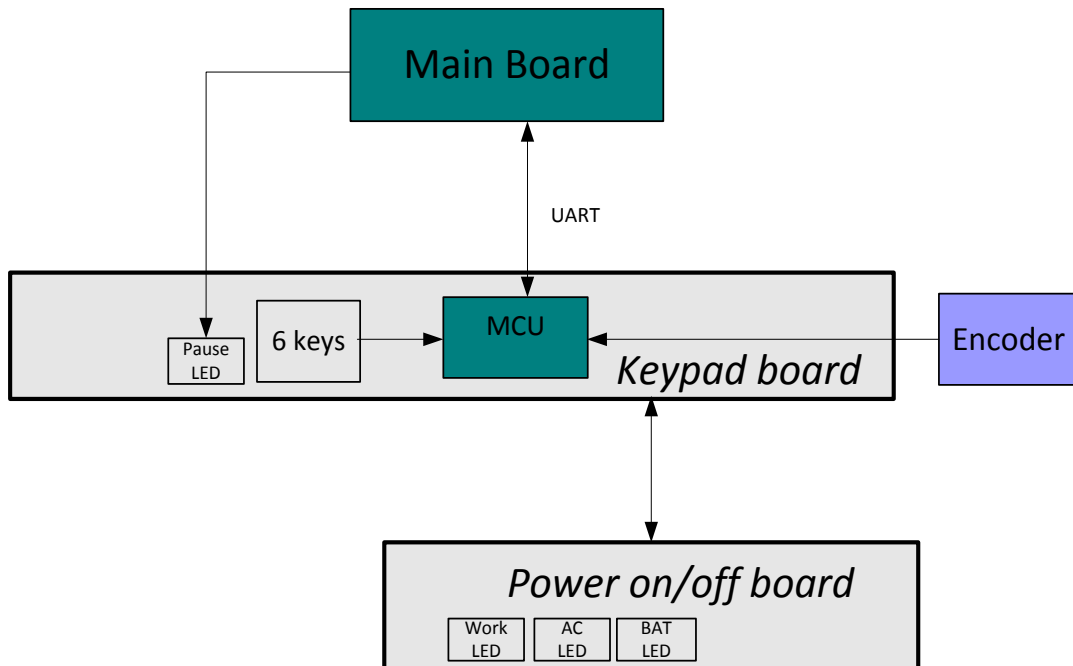

### 2.4.3 Power On/Off and LED Indicator Board

The power on/off and LED indicator board is connected with the keypad. It controls the patient monitor's power switch. It has 3 groups of indicators which are used to indicate the status of AC mains, battery, as well as the monitor's power on/off status.

### 2.4.4 Alarm Lamp Board

The alarm lamp board is located at the top of the front housing. It has two-color indicators, red and yellow. The alarm lamp board directly connects the main board through a cable. It is controlled directly by the main board.

### 2.4.5 Display

iMEC8/iMEC5, iMEC10/iMEC6, iMEC12/iMEC7 and iMEC15/iMEC15S respectively support 8-inch, 10-inch, 12-inch and 15-inch LCDs. The display connects the main board through a display signal cable and a backlight cable. The interface cables for the three types of patient monitors are different and cannot be mixed. The reliability of display signal cable is relatively poor. If display problem occurs, consider first to replace the display signal cable.

### 2.4.6 Touchscreen and Touchscreen Control Board

The fully configured iMEC patient monitor supports touchscreen. The touchscreen can be controlled by touch and can be calibrated. The touchscreen is connected with the touchscreen control board and the main board.

The touchscreen control board drives the touchscreen and implements communication with the patient monitor. The touchscreen control board communicates with the main board via an I2C interface and connects the touchscreen via FPC.

## 2.5 Rear Housing Assembly

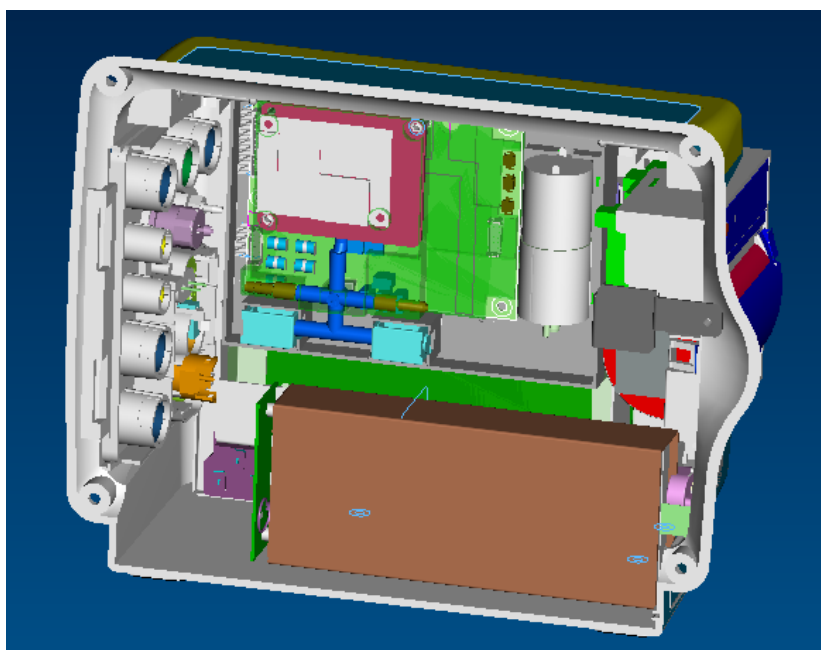

The rear housing assembly mainly includes power management system, multi-parameter collecting and processing system, recorder, and speaker. The power management system consists of three key components: AC/DC power board, DC/DC and power management, battery and battery back board. The structure is shown below:

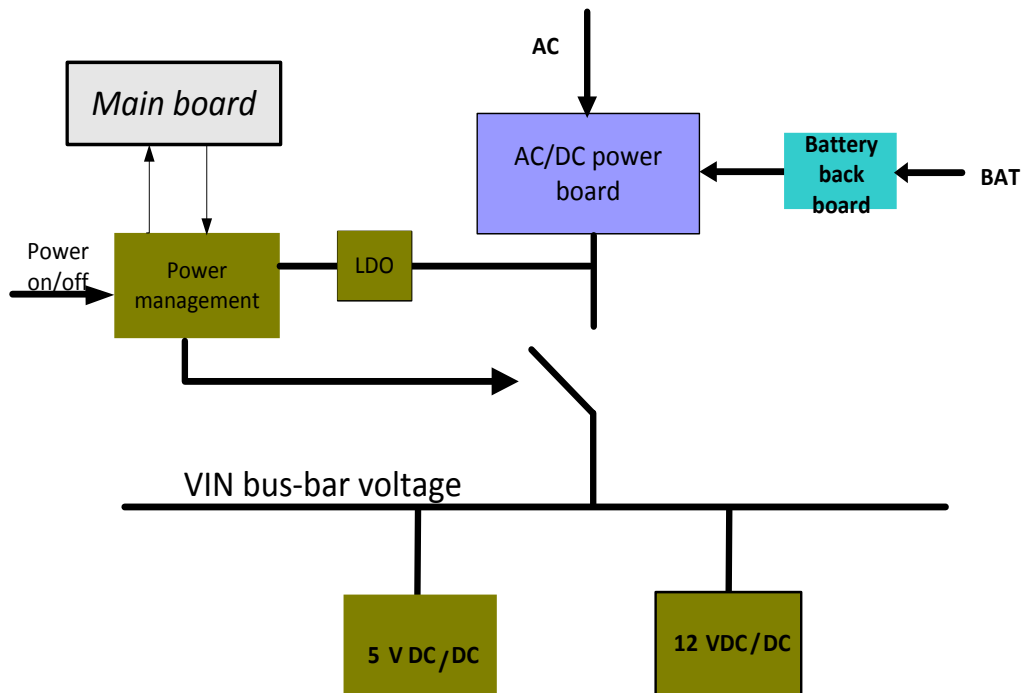

Brown circuits are placed on the connector board. The three boards are introduced respectively in the following:

### 2.5.1 AC/DC Power Board

The AC/DC power board is located at the metal sheet of battery compartment at the lower part of the patient monitor. It transforms the input AC (100 to 240V AC, 50/60 Hz) into 15.2 V bus voltage VIN, which is the power source for all voltages in the patient monitor. The AC/DC power board supplies power for all modules through the two-pin power cord connecting to the interface board.

### 2.5.2 Interface Board (DC/DC, Power Management Circuit)

The interface board mainly performs DC/DC conversion, power management, and transmission of external connector signals:

- DC-DC: Output 12 V (10.8 to 12.6V), 5V +/- 5%
- Power management and interface
- DC/DC conversion circuit
- Single lithium battery charging and discharging management
- Power on/off control: no power-on delay, and power-off delay
- Battery type detection (current high-capacity and low capacity lithium batteries)
- Battery on-site detection
- Battery voltage (capacity) detection
- AC or battery power source detection

- Temperature check
- Communication with main board
- External connector signal transfer (RJ45, USB, multi-functional connector, and VGA)

The interface board is the signal center of the whole system. All boards in rear housing assembly needs to communicate with main board through the transfer of interface board. The interface definitions are:

- Multi-parameter module connector (2 × 7 pin)
- CO<sub>2</sub> connector (5 pin)
- M03B-C.O. module connector (4 pin)
- Recorder (6 pin)
- AC-DC power board (2 pin)
- Battery back board (2 × 4 pin)
- Speaker (2 pin)
- External connector (directly welt on the board): network, USB, VGA, multi-functional connector
- Main board connector (2 × 25 pin)
- Reserved serial port

All connectors are designed with mechanical barriers to prevent mis-operations in production or maintenance. The interface board has two types of configuration:

Configuration Type	Common Requirement	Difference
Standard (support patient monitors of standard configuration)	RJ45	No other ports
Extended (support patient monitors other than standard ones)		USB, VGA, multi-functional output

### 2.5.3 Battery Back Board

The iMEC patient monitor consumes low power thanks to the better system design. One lithium battery is capable to supply the power for the whole system. The battery back board transmits the signal of battery capacity and status into the internal system. The patient monitor only supports lithium battery. The on-site detection of lithium battery is achieved by the resistance inside the battery. A new battery provides two types of information by 2 pins:

- Battery on-site information
- Battery low/high capacity information

The patient monitor supports 11.1 V lithium chargeable battery. The battery is located at the base of the patient monitor. The battery power is input into power module through battery interface board, and then power module processes and forwards the power into each components of the patient monitor. Two types of batteries are supported:

- Current high-end lithium battery 4500 mAh
- New developed low capacity lithium battery 2600 mAh

The battery is designed with mechanical barriers for correct type and insertion. The patient monitor requires a battery of correct type to be inserted in correct direction. Otherwise, the battery cannot be loaded.

### 2.5.4 Parameter Module

The parameter module is a relatively independent system, which consists of a multi-parameter module and a SpO<sub>2</sub> board, as shown below:

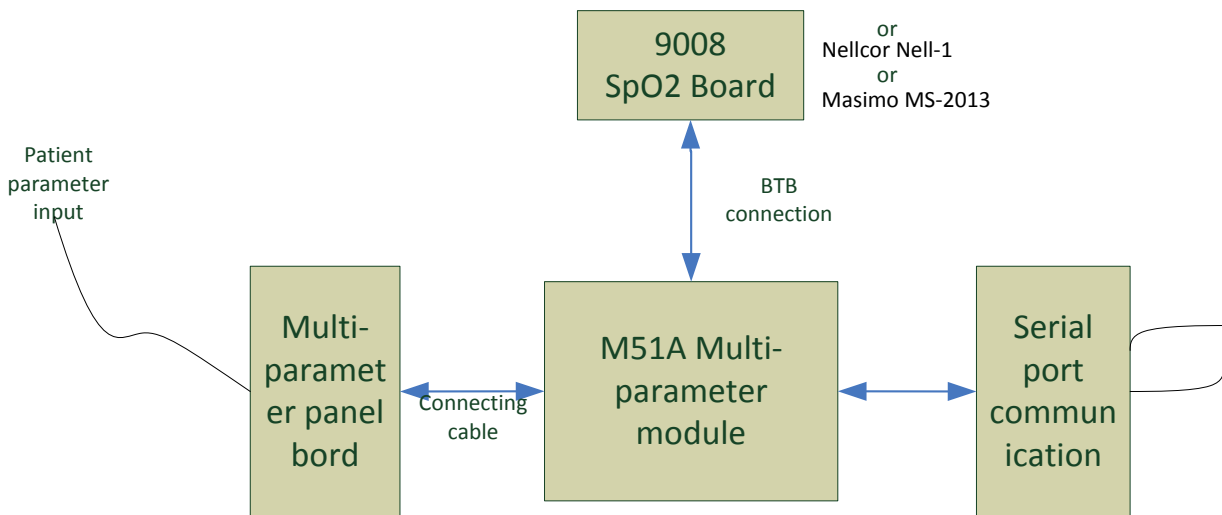

### 2.5.5 Multi-parameter Module

The multi-parameter module, as well as the NIBP pump and electromagnetic valve, are located on the bracket of the multi-parameter module, which is fixed to the rear housing with four screws.

The multi-parameter module is connected to the connector board with a 2 × 7 pin cable to supply power for the parameter module, communicate with the main board, and realize analog output and Defib sync output. It adopts the DSP processor as the core. For ECG applications, the self-developed Mindray ECG\_ASIC chip is used to realize 3/5/12-lead ECG, and Resp (I/II lead selectable) measurement, which greatly simplifies the sampling and control of ECG signals for the DSP.

As for NIBP, IBP, and Temp measurement, the high-precision  $\Sigma - \Delta$  ADC is used to realize a direct sampling of corresponding parameter signals. Mindray SpO<sub>2</sub> measurement is realized by a tacking connector. The Nellcor and Masimo SpO<sub>2</sub> boards are also compatible with the multi-parameter module, being connected through a BTB socket.

- Supports 2-channel 3-/5-lead ECG monitoring (and 12-lead in future), and I/II lead Resp monitoring
- Provides power for and communicates with Mindray/Nellcor/Masimo SpO<sub>2</sub> board
- Supports 2-channel Temp monitoring
- Supports 2-channel IBP monitoring
- Supports NIBP monitoring
- Processes all algorithms and communicates with the main board via UART
- Realizes analog output (four channels, one for ECG, two for IBP, and the other for Defib sync output)
- Isolates the parameter modules from the earth
- Isolates ECG from other parameters

### 2.5.6 SpO<sub>2</sub> Board

The multi-parameter module supports the independently developed Mindray SpO<sub>2</sub> board, which provides SpO<sub>2</sub> measurement as good as other boards but with smaller size and lower consumption. It is also compatible with Nellcor NELL-1 SpO<sub>2</sub> board and Masimo MS-2013 SpO<sub>2</sub> board.

SpO<sub>2</sub> board is used to collect SpO<sub>2</sub> signals transmitted by the multi-parameter module and process SpO<sub>2</sub> algorithms.

### 2.5.7 C.O. Module

The C.O. module is located on the back of the bracket of the multi-parameter module. facing the multi-parameter module with the bracket in between. The current on-line M03B module is used for C.O. measurement. The C.O. module is an independent subsystem. It is connected to the main board through the serial port and interface board.

### 2.5.8 CO<sub>2</sub> Module

The CO<sub>2</sub> module is also located on the back of the back of the bracket of the multi-parameter module, next to the C.O. module. The CO<sub>2</sub> module is an independent subsystem. It is connected to the main board through the serial port and interface board. The socket for CO<sub>2</sub> module on the interface board is 5-pin, different from that for C.O. module, which avoids mis-operation.

Three gas modules, which can be selected in corresponding menu, are supported on the patient monitor:

- M02C sidestream module
- Capnostat mainstream CO<sub>2</sub> module
- Oridion microstream CO<sub>2</sub> module

## 2.5.9 Recorder

The recorder receives data from the main board and then sends them to the thermal printhead for printing. The recorder has a hard key (starting/stopping recordings) and a green LED on its front. It is connected with the main board.

The following diagram shows its operating principle:

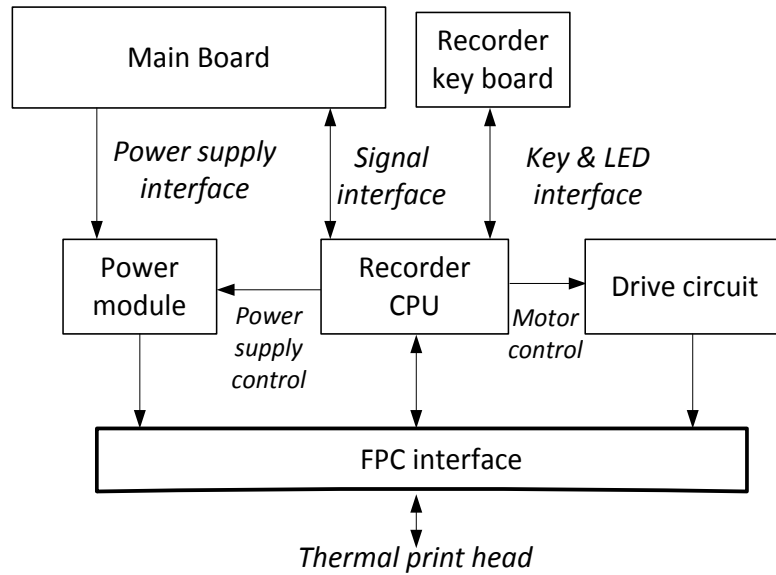

Module	Description
Power interface	Introduces a DC from the main board.
Power module	Converts the input power into voltages that fit each module and then forwards them to each module.
CPU	Control the communications between modules.
Signal interface	Control the communication between the main board and the recorder CPU.
Motor drive circuit	Receives the control signals from the CPU and then forwards them to the step engines.
Key&LED interface	Includes a button and an LED which are directly controlled by the CPU.

## 2.6 Speaker

The speaker provides sound for alarms, key strokes, heartbeats and pulse, and allows PITCH TONE and multi-level tone modulation. It is connected with the main board and is directly driven by the main board.



# 3 Unpacking and Installation

---

## 3.1 Unpacking the Equipment

Open the package and take out the packing list. Check that all the articles included in the packing list are available and the quantity and specification are correct. Make sure that:

- All the optional parts purchased by the customer shall also be checked.
- Notify the supplier if provided components are not correct as compared to the packing list.
- In case of damage during transportation, keep the packing material and notify the supplier immediately.
- Keep the packing material till new equipment is accepted.

The following pictures show the patient monitor and accessory packing.



Main unit packing



Accessory packing

## 3.2 Preparation for Installation

### 3.2.1 Preparation for Installation Site

1. Ensure that the site meets all safety, environmental and power requirements.
2. Check that required power sockets are available.
3. Check that a network connector is available if the patient monitor needs to be connected to network.

#### Environmental Requirements

To avoid explosion hazard, do not use the equipment in the presence of flammable anesthetics, vapors or liquids. The environment where the patient monitor will be used should be reasonably free from vibration, dust and corrosive substances. If these conditions are not met, the system may not function normally.

The environmental specification is as follows:

<b>Main unit</b>			
<b>Item</b>	<b>Temperature (°C)</b>	<b>Relative humidity (noncondensing)</b>	<b>Altitude (kPa)</b>
Operating environment	0 to 40	15% to 95%	57.0 to 107.4
Storage environment	-20 to 60	10% to 95%	16.0 to 107.4

<b>Mainstream CO<sub>2</sub> module</b>			
<b>Item</b>	<b>Temperature (°C)</b>	<b>Relative humidity (noncondensing)</b>	<b>Altitude (kPa)</b>
Operating environment	0 to 40	15% to 90%	57.0 to 107.4
Storage environment	-20 to 60	10% to 90%	53.3 to 107.4

<b>Sidestream CO<sub>2</sub> module</b>			
<b>Item</b>	<b>Temperature (°C)</b>	<b>Relative humidity (noncondensing)</b>	<b>Altitude (kPa)</b>
Operating environment	5 to 40	15% to 95%	57.3 to 105.3
Storage environment	-20 to 60	10% to 95%	57.3 to 105.3

<b>Microstream CO<sub>2</sub> module</b>			
<b>Item</b>	<b>Temperature (°C)</b>	<b>Relative humidity (noncondensing)</b>	<b>Altitude (kPa)</b>
Operating environment	0 to 40	15% to 95%	57.3 to 105.3
Storage environment	-20 to 60	10% to 95%	57.3 to 105.3

#### NOTE

- The environmental specifications of unspecified parameters are the same as those of the main unit.

### 3.2.2 Electrical Requirements

Check cables and power cords. Make sure that:

1. Check that the system cables, power cords, and power plugs are not damaged, and pins are not loose. In case of any damage, remove it from use.
2. The insulation of patient cables and leadwires is not damaged, and connectors are not loose.

---

 **WARNING**

---

- Only power sockets with protective grounding can be used.
- 

<b>Line voltage</b>	100 to 240V AC
<b>Current</b>	1.1 to 0.5 A
<b>Frequency</b>	50/60 Hz

### 3.2.3 Monitor Installation

Refer to *iMEC15S/iMEC15/iMEC12/iMEC10/iMEC8/iMEC7/iMEC6/iMEC5 Patient Monitor Operator's Manual*.

### 3.2.4 Preparation for Power on

1. Before you start to make measurements, check the patient monitor for any mechanical damage and make sure that all external cables, plug-ins and accessories are properly connected.
2. Plug the power cord into the AC power source. If you run the patient monitor on battery power, ensure that the battery is sufficiently charged.
3. Press the power on/off switch on the monitor's front.

**FOR YOUR NOTES**

# 4 Hardware and Software Upgrade

---

## 4.1 Introduction

iMEC patient monitors supports upgrade of parameter modules, functional assemblies, and software (with network upgrade tool).

---

### NOTE

- Before disassembling the equipment, if necessary for the upgrade, be sure to eliminate the static charges first. When disassembling the parts labeled with static-sensitive symbols, make sure you are wearing electrostatic discharge protection such as antistatic wristband or gloves to avoid damaging the equipment.
  - Properly connect and route the cables and wires when reassembling the equipment to avoid short circuit.
  - Select appropriate screws to assemble the equipment. If unfit screws are tightened by force, the equipment may be damaged and the screws or part may fall off during use, causing unpredictable equipment damage or human injury.
  - Follow correct sequence to disassembly the equipment. Otherwise, the equipment may be damaged permanently.
  - Disconnect all the cables before disassembling any parts. Be careful not to damage any cables or connectors.
  - Place removed screws and disassembled parts properly, preventing them from being lost or contaminated.
- 

## 4.2 Hardware Upgrade

### 4.2.1 Upgrading the 1G SD Storage Card

#### 4.2.1.1 Upgrade Package

Upgrade package	Monitor config. before upgrade	Description of upgrade package	PN of upgrade package
1G SD storage card	Main board (standard configuration)	1G SD storage card upgrade kit (iMEC8)	801-6302-00008-00
	Main board (standard configuration)	1G SD storage card upgrade kit (iMEC10)	801-6303-00006-00
	Main board (standard configuration)	1G SD storage card upgrade kit (iMEC12)	801-6301-00012-00
	Main board (full configuration)	1G SD storage card upgrade kit (without main board)	801-6301-00026-00

### 4.2.1.2 Upgrade Method

1. Select the correct upgrade kit based on the product model and configuration. For monitors with fully configured main board, select the upgrade kit without main board.
2. Separate the front and rear housing as described in **7.3.1 Separating the Front and Rear Half of the Monitor**. For monitors with standard configuration, the main board shall also be disassembled as described in **7.4.4 Removing the Main Board**.
3. Install the main board (only for monitors with standard configuration), SD storage card, and screws in the upgrade kit into the front housing assembly as described in the sub-chapters of **7.4 Disassembling the Front Housing Assembly**. For iMEC8/iMEC5 patient monitors, the shield cover and its insulation sheet shall be installed on the main board.
4. Re-assembly the equipment correctly.

When the hardware is assembled correctly as per the above procedure, connect the equipment with AC power, turn on the equipment, and select [Main Menu] → [Maintenance] → [Factory Maintenance >>] → enter the required password → [Device Config >>] to access the device configuration menu. Select [Storage Card] and close the device configuration menu. Exit factory maintenance and turn off the equipment. Then, restart the equipment, wait for a few seconds, and select [Main Menu] → [Review]. If [Full Closure] is displayed in the menu, the SD card is upgraded successfully.

## 4.2.2 Upgrading Touchscreen

### 4.2.2.1 Upgrade Package

Upgrade package	Monitor config. before upgrade	Description of upgrade package	PN of upgrade package
Touchscreen	Standard Configuration	Touchscreen upgrade kit (iMEC8, with no silicon keys)	801-6302-00009-00
	Standard Configuration	Touchscreen upgrade kit (iMEC10, with no silicon keys)	801-6303-00007-00
	Standard Configuration	Touchscreen upgrade kit (iMEC12, with no silicon keys)	801-6301-00013-00

### 4.2.2.2 Upgrade Method

1. Separate the front and rear housing as described in **7.3.1 Separating the Front and Rear Half of the Monitor**. Then take out the silicon keys from the original front housing and install them onto the front housing assembly in the upgrade kit as described in the sub-chapters of **7.4 Disassembling the Front Housing Assembly**.
2. Re-assembly the equipment correctly.

When the hardware is assembled correctly as per the above procedure, connect the equipment with AC power, turn on the equipment, and select **[Main Menu]** → **[Maintenance]** → **[Factory Maintenance >>]** → enter the required password → **[Device Config >>]** to access the device configuration menu. Select **[Touchscreen]** and close the device configuration menu. Exit factory maintenance and turn off the equipment. Then restart the equipment, wait for a few seconds, and select **[Main Menu]** → **[Maintenance]** → **[Cal. Touchscreen]** to calibrate the touchscreen. When the calibration is done, if the message "**Screen Calibration Completed!**" is displayed, the touchscreen is successfully upgraded on this equipment.

## 4.2.3 Upgrading Wi-Fi

### 4.2.3.1 Upgrade Package

Upgrade package	Monitor config. before upgrade	Description of upgrade package	PN of upgrade package
Wi-Fi	Main board (standard configuration)	Wi-Fi upgrade kit (iMEC8)	801-6302-00010-00
	Main board (standard configuration)	Wi-Fi upgrade kit (iMEC10)	801-6303-00008-00
	Main board (standard configuration)	Wi-Fi upgrade kit (iMEC12)	801-6301-00014-00
	Main board (full configuration)	Wi-Fi upgrade kit (without main board)	801-6301-00027-00

### 4.2.3.2 Upgrade Method

1. Select the correct upgrade kit based on the product model and configuration. For monitors with fully configured main board, select the upgrade kit without main board.
2. Separate the front and rear housing as described in **7.3.1 Separating the Front and Rear Half of the Monitor**. For monitors with standard configuration, the main board shall also be disassembled as described in **7.4.4 Removing the Main Board**.
3. Install the main board (only for monitors with standard configuration), the antenna, and the Cyberlink (Wi-Fi) module as described in **7.4.2 Removing Antenna (Optional)**, and then manage the cables properly. For iMEC8/iMEC5 patient monitors, the shield cover and its insulation sheet shall be installed on the main board.
4. Re-assembly the equipment correctly.

When the hardware is assembled correctly as per the above procedure, connect the equipment with AC power, turn on the equipment, and select **[Main Menu]** → **[Maintenance]** → **[User Maintenance >>]** → enter the required password → **[Network Setup >>]** → **[Network Type >>]**. If you can select **[WLAN]** in the menu, the Wi-Fi function is upgraded successfully.

If Wi-Fi module function test is needed, configure the wireless network setting on the patient monitor and connect to a nearby wireless network as described in the **Network Connection** chapter in **iMEC15S/iMEC15/iMEC12/iMEC10/iMEC8/iMEC7/iMEC6/iMEC5 Patient Monitor Operator's Manual**, and make sure the connection succeeds.

## 4.2.4 Upgrading Recorder

### 4.2.4.1 Upgrade Package

Upgrade package	Monitor config. before upgrade	Description of upgrade package	PN of upgrade package
Recorder	/	Recorder upgrade kit (iMEC8)	801-6302-00011-00
	/	Recorder upgrade kit (iMEC8, with tapping screws)	801-6302-00014-00
	/	Recorder upgrade kit (iMEC10/12)	801-6301-00015-00

### 4.2.4.2 Upgrade Method

1. Select the correct upgrade kit based on the product model and configuration. For iMEC8/iMEC5 patient monitors, the upgrade kits shall be selected based on the screw type on the original rear panel.

#### iMEC12/iMEC7/iMEC10/iMEC6

2. Separate the front and rear housing as described in **7.3.1 Separating the Front and Rear Half of the Monitor.**
3. Fix the recorder bracket onto the rear housing with two M3×6 screws, as shown below; for rear housing with no hot pressed nuts, use two PT3×8 tapping screws to fix the recorder bracket.

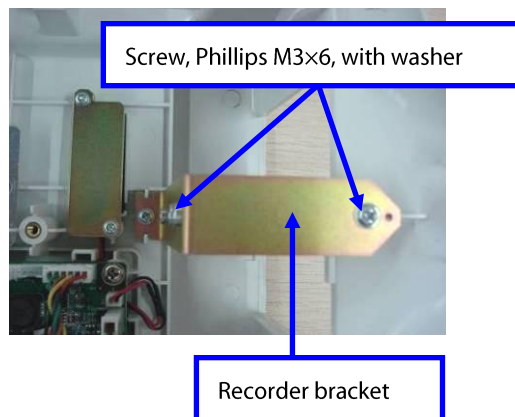

4. Insert one end of the recorder cable into the J10 socket on the interface board and the other end to the recorder. Then fix the recorder onto the rear housing with two M3×6 screws as shown below:

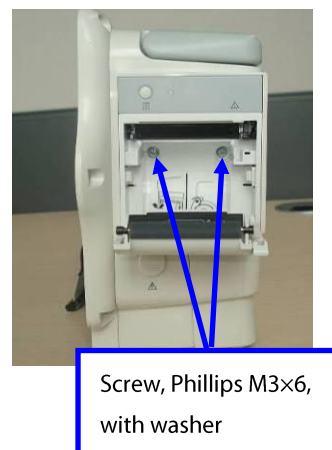
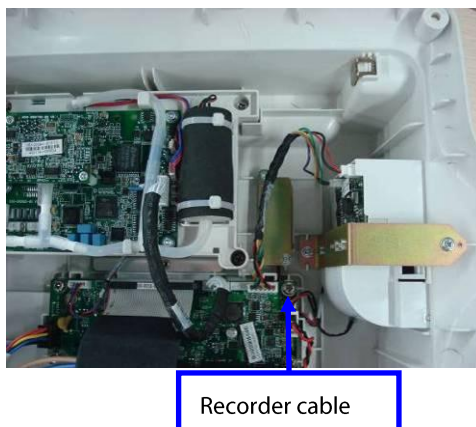

5. Re-assembly the equipment correctly.



## iMEC8/iMEC5

2. Separate the front and rear housing as described in **7.3.1 Separating the Front and Rear Half of the Monitor**, and then take out the parameter module and interface panel as described in step 1 in **7.3.2 Removing the Parameter Connector Panel Assembly**.
3. Fix the recorder bracket, connect the recorder cable and install the recorder as described in steps 3 and 4 in **iMEC12/iMEC7/iMEC10/iMEC6**.
4. Install the parameter module and interface panel, and reassemble the equipment correctly.

When the hardware is assembled correctly as per the above procedure, connect the equipment with AC power, turn on the equipment, and select [Main Menu] → [Maintenance] → [Factory Maintenance >>] → enter the required password, and then in the maintenance menu, select [Recorder >>] and change the setting to [ON]. Exit factory maintenance and turn off the equipment. Then restart the equipment, wait for a few seconds, install the papers, and perform printing test as per **5.9 Recorder check**.

## 4.2.5 Upgrading CO<sub>2</sub>

### 4.2.5.1 Upgrade Package

Upgrade package	Monitor config. before upgrade	Description of upgrade package	PN of upgrade package
CO <sub>2</sub>	/	Mindray sidestream CO <sub>2</sub> upgrade kit	801-6301-00016-00
	/	Capnostat mainstream CO <sub>2</sub> upgrade kit	801-6301-00017-00
	/	Oridion microstream CO <sub>2</sub> upgrade kit	801-6301-00018-00

### 4.2.5.2 Upgrade Method

#### Upgrading Mindray Sidestream CO<sub>2</sub>

1. Remove the parameter panel assembly and parameter module assembly as described in **7.3.2 Removing the Parameter Connector Panel Assembly**, and then delacerate the original labels on the parameter panel assembly.
2. Install the watertrap socket onto the parameter panel assembly as described in **7.7.3 Removing the Watertrap Base Assembly (Optional)**.
3. Fix the gas outlet nozzle onto the parameter panel with an M5 nut, as shown below:

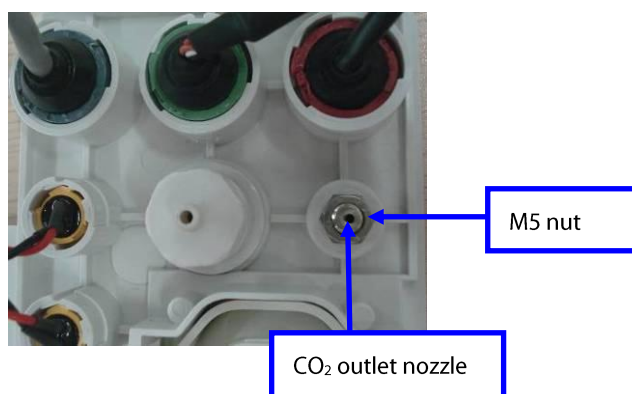

4. Install the M02C module into the parameter module assembly as described in **7.6.1 Removing the Mindray M02C CO<sub>2</sub> Module (Optional)**.

5. Connect the parameter panel and gas pipes of corresponding parameter modules as described in **7.3.3 Disassembling the Parameter Module Assembly**. Make sure the pipes are inserted in position.
6. Re-assembly the equipment correctly.
7. Select appropriate parameter labels from the upgrade kit and paste them onto the parameter panel based on the configuration of the serviced equipment.
8. Install the AC inlet hook as shown in the figure below. Make sure the direction is correct.



### Upgrading Capnostat Mainstream CO<sub>2</sub>

1. Remove the parameter panel assembly and parameter module assembly as described in **7.3.2 Removing the Parameter Connector Panel Assembly**, and then split the original labels on the parameter panel assembly.
2. Install the mainstream CO<sub>2</sub> interface board to the parameter panel assembly and fix in position as described in **7.7.1 Removing the Mainstream CO<sub>2</sub> Signal Cable (Optional)**.
3. Fix the right end of the mainstream CO<sub>2</sub> bracket into the positioning pillar in the parameter board bracket, and then fix the bracket for mainstream CO<sub>2</sub> onto the parameter module bracket with two M3×6 screws. Insert the 4-pin plug of the cable between the interface board and mainstream converter board into the J1 socket on the 6301 mainstream CO<sub>2</sub> insulation power board.

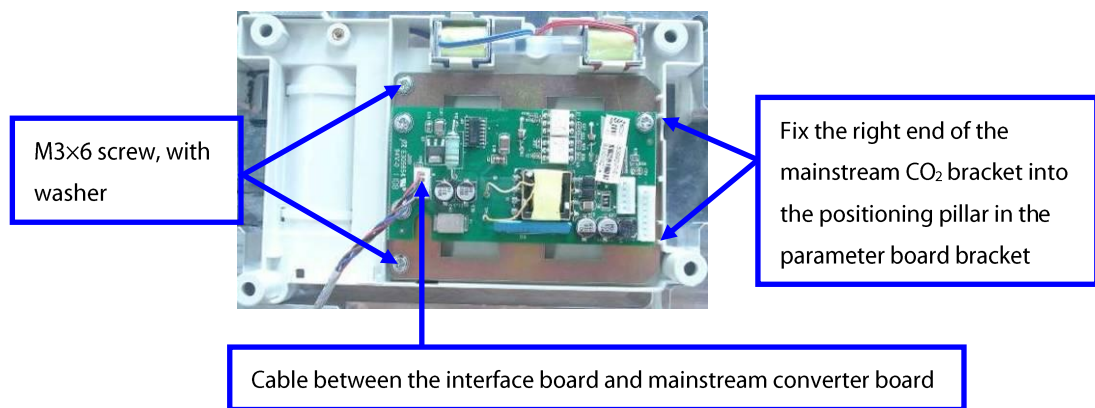

4. Connect the mainstream signal cable of the parameter panel to the J3 socket as described in **7.3.3 Disassembling the Parameter Module Assembly**.
5. Re-assembly the equipment correctly.
6. Select appropriate parameter labels from the upgrade kit and paste them onto the parameter panel based on the configuration of the serviced equipment.

7. Install the AC inlet hook as shown in the figure below. Make sure the direction is correct.



### Upgrading Oridion Microstream CO<sub>2</sub>

1. Remove the parameter panel assembly and parameter module assembly as described in **7.3.2 Removing the Parameter Connector Panel Assembly**, and then split the original labels on the parameter panel assembly.
2. Assemble the microstream CO<sub>2</sub> connector assembly to the parameter connector assembly as described in **7.7.2 Removing the Microstream CO<sub>2</sub> Connector Assembly (Optional)**. Make sure it is assembled in position.
3. Fix the gas outlet nozzle onto the parameter panel with an M5 nut, as shown below:

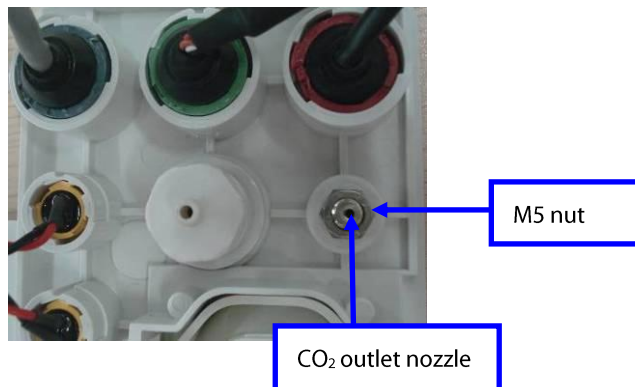

4. Install the microstream CO<sub>2</sub> module into the parameter module assembly as described in **7.6.3 Removing the Microstream CO<sub>2</sub> module (Optional)**.
5. Connect the parameter panel and parameter module pipe as described in **7.3.3 Disassembling the Parameter Module Assembly**. Make sure the pipe is inserted in position. Then install the microstream CO<sub>2</sub> connector into the microstream CO<sub>2</sub> connector assembly.
6. Re-assemble the equipment correctly.
7. Select appropriate parameter labels from the upgrade kit and paste them onto the parameter panel based on the configuration of the serviced equipment.
8. Install the AC inlet hook as shown in the figure below. Make sure the direction is correct.



When the hardware is assembled correctly as per the above procedure, connect the equipment with AC power, turn on the equipment, and select [Main Menu] → [Maintenance] → [Factory Maintenance >>] → enter the required password → [Device Config >>] to access the device configuration menu. Select the upgraded CO<sub>2</sub> module in the CO<sub>2</sub> module menu, close the device configuration menu, exit factory maintenance, and turn off the equipment. Then restart the equipment, wait for a few minutes, and perform CO<sub>2</sub> module test as described in **5.4 Module Performance Tests**.

## 4.2.6 Upgrading C.O.

### 4.2.6.1 Upgrade Package

Upgrade package	Monitor config. before upgrade	Description of upgrade package	PN of upgrade package
C.O.	/	C.O. upgrade kit	801-6301-00019-00

### 4.2.6.2 Upgrade Method

1. Remove the parameter panel assembly and parameter module assembly as described in **7.3.2 Removing** the Parameter Connector Panel Assembly, and then split the original labels on the parameter panel assembly.
2. Assemble the C.O. interface signal cable to the correct position on the parameter panel assembly as described in **7.6.4 Removing** the C.O. Module (Optional).
3. Insert the bottom of the C.O. board into the slot of the parameter board bracket and fix the C.O. board onto the bracket with a M3×6 screw. Then connect the cable between the interface board and M03B module through the P1 socket on the C.O. board.

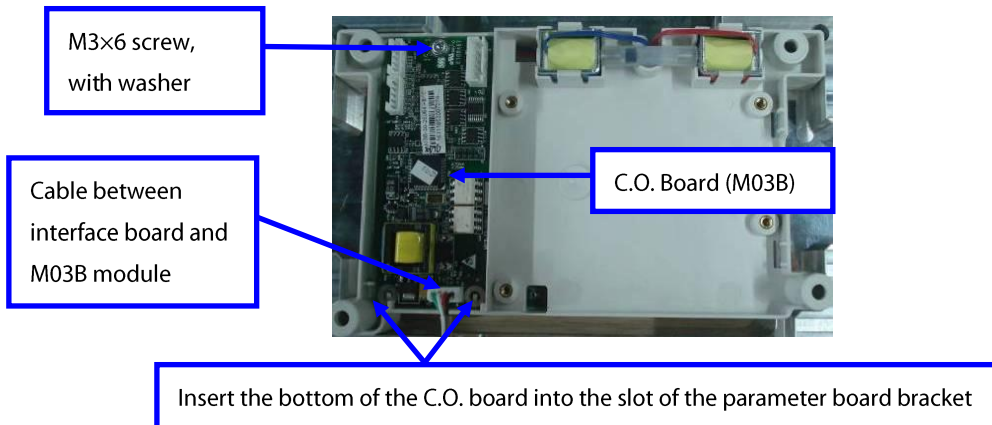

4. Insert the C.O. signal cable into the correct socket on the C.O. board as described in **7.3.3 Disassembling** the Parameter Module Assembly.
5. Re-assemble the equipment correctly.
6. Select appropriate parameter labels from the upgrade kit and paste them onto the parameter panel based on the configuration of the serviced equipment.

When the hardware is assembled correctly as per the above procedure, connect the equipment with AC power, turn on the equipment, and select [Main Menu] → [Maintenance] → [Factory Maintenance >>] → enter the required password → [Device Config >>] to access the device configuration menu. Select C.O. module and close the device configuration menu. Exit factory maintenance and turn off the equipment. Then restart the equipment, wait for a few minutes, and perform C.O. module test as described in **5.4.7 C.O. Test**.

## 4.2.7 Upgrading IBP

### 4.2.7.1 Upgrade Package

Upgrade package	Monitor config. before upgrade	Description of upgrade package	PN of upgrade package
IBP	/	IBP upgrade kit (for monitors with Masimo SpO <sub>2</sub> )	801-6301-00020-00
	/	IBP upgrade kit (for monitors with Mindray SpO <sub>2</sub> )	801-6301-00021-00
	/	IBP upgrade kit (for monitors with Nellcor SpO <sub>2</sub> )	801-6301-00022-00

### 4.2.7.2 Upgrade Method

1. Remove the multi-parameter module from the parameter module assembly as described in **7.6.6 Removing the Multi-parameter Module**.
2. Install the multi-parameter module in the upgrade kit, and then reassemble the parameter module assembly correctly.
3. Install the parameter panel assembly in the upgrade kit, and then select appropriate parameter labels from the upgrade kit and paste them onto the parameter panel based on the configuration of the serviced equipment.
4. Re-assembly the equipment correctly.

When the hardware is assembled correctly as per the above procedure, connect the equipment with AC power, turn on the equipment, and select **[Main Menu]** → **[Maintenance]** → **[Factory Maintenance >>]** → enter the required password → **[Device Config >>]** to access the device configuration menu. Select IBP1/IBP2 module and close the device configuration menu. Exit factory maintenance and turn off the equipment. Then restart the equipment, wait for a few minutes, and perform IBP module test as described in **5.4.6 IBP Test and Calibration**.

## 4.2.8 Upgrading VGA/USB/Multi-functional Interface

### 4.2.8.1 Upgrade Package

Upgrade package	Monitor config. before upgrade	Description of upgrade package	PN of upgrade package
VGA/USB/Multi-functional interface	Main board (standard configuration)	VGA/USB/Multi-functional interface upgrade kit (iMEC8)	801-6302-00012-00
	Main board (standard configuration)	VGA/USB/Multi-functional interface upgrade kit (iMEC10)	801-6303-00009-00
	Main board (standard configuration)	VGA/USB/Multi-functional interface upgrade kit (iMEC12)	801-6301-00023-00
	Main board (full configuration)	VGA/USB/Multi-functional interface upgrade kit (iMEC8, without main board)	801-6302-00015-00
	Main board (full configuration)	VGA/USB/Multi-functional interface upgrade kit (iMEC12/10, without main board)	801-6301-00028-00

#### 4.2.8.2 Upgrade Method

1. Select the correct upgrade kit based on the configuration of the serviced equipment. For monitors with full configuration, select upgrade kits with no main boards.
2. Remove the multi-parameter module from the parameter module assembly as described in **7.6.6 Removing the Multi-parameter Module**, and then remove the power management and interface board on the rear housing. For monitors with standard configuration, the main board on the front housing shall also be removed.
3. Install the multi-parameter module, main board (only for monitors with standard configuration), and power management and interface board. For iMEC8/iMEC5 patient monitors, the shield cover and its insulation sheet shall be installed on the main board, and for iMEC12/iMEC7/iMEC10/iMEC6 patient monitors, the grounding sheet shall also be installed.



4. Re-assembly the equipment correctly.
5. Replace the original IO label on the rear housing with the one (with full configuration) in the upgrade kit.



When the hardware is assembled correctly as per the above procedure, connect the equipment with AC power, turn on the equipment, and perform test on the nurse call and analog output functions as described in chapters **5.5 Nurse Call Function Test** and **5.6 Analog Output Performance Test**.

Connect to a VGA display. If the monitoring information is correctly displayed on the VGA display, the VGA function is upgraded successfully.

Connect a USB device to the patient monitor through the USB connector. If the USB icon is displayed at the left corner of the screen, the USB function is upgraded successfully. Access the configuration management menu on the patient monitor and select (main menu --> maintenance --> manage configuration --> enter the required password --> ) **[User Maintenance]**, and then **[Export Config.]**. When the export is finished, the message "**Configurations exported successfully!**" shall be displayed. Select **[Import Configuration]**. When the import is finished, the message "**Configurations imported successfully!**" shall be displayed. If so, the USB function is upgraded successfully.

## 4.3 Software Upgrade

You can upgrade system software and module software by installing and running the Mindray Patient Monitor Software Upgrade Tool (PN: G-110-000493-00) on a PC with Windows operating system. Connect the monitor to be upgraded and a PC running the upgrade tool to the same network, or directly connect the monitor and the PC via a crossover network cable. Then configure the IP address of the PC. You can upgrade the following software:

Software	PN	Description
Boot program	110-001792-00	BIOS program
System software	110-001851-00	System software
Language lab	110-001795-00	Multilingual library
BMP resource file	110-001796-00	Icon library
	110-001847-00	Welcome LOGO
LINUX platform software	110-001848-00	LINUX kernel (including drive)
Module software	110-001861-00	MO software for power management board
	110-001839-00	DSP (BF512) software for M51A V2.0 module
	110-000539-00	Software for 9008 SpO <sub>2</sub> module
	110-001838-00	STM32 software for M02C module
	M03B-30-86661	Software for M03B module (download online)

All programs except the module software will be cleared during the upgrade of LINUX kernel (including drive). Therefore, remember to upgrade the system software and boot program etc. after the LINUX kernel (including drive) is upgraded.

### 4.3.1 Installing Mindray Patient Monitor Software Upgrade Tool (PN: G-110-000493-00)

1. Find the installation program  SystemUpdateTool.exe and double click it to start installation.
2. Select language.

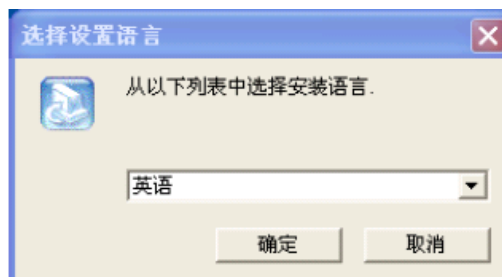

3. Click **[Ok]** and the following screen is displayed. Click **[Next]** to go to the next step.

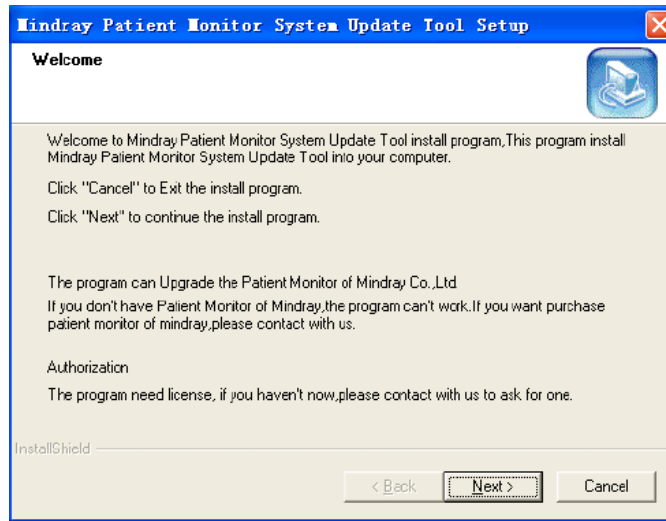

4. Enter User Name, Company name, and Serial Number "26582640". Then click **[Next]**.

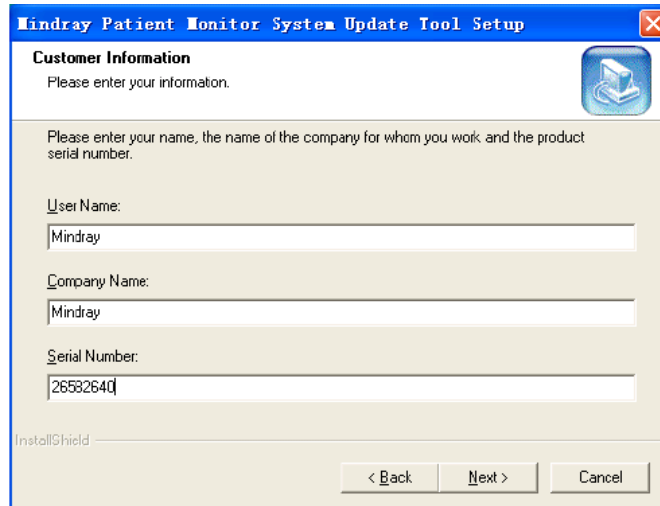

5. Specify the destination folder for installing this program. Then select **[Next]**.

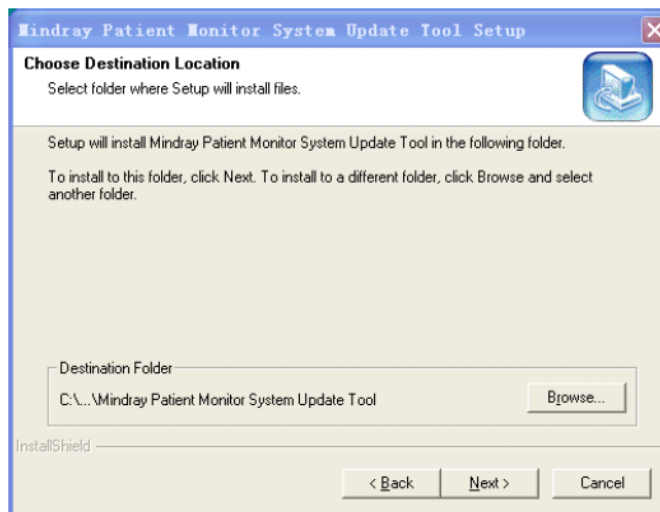



6. Select Program Folder. Then select **[Next]**.

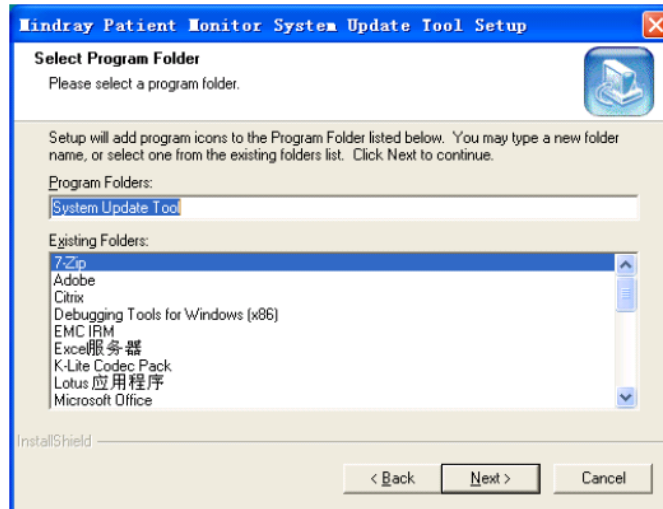

7. Click **[Finish]** to complete installation.

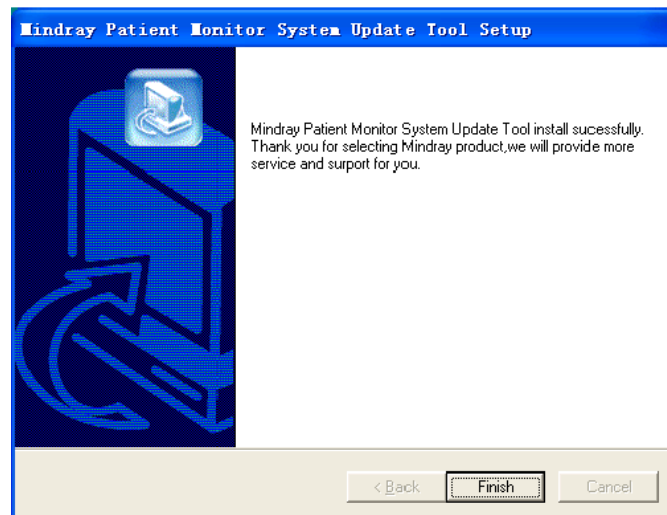

### 4.3.2 Software Upgrade Procedure

1. Connect the patient monitor to a PC through a network cable. Set the IP to 77.77.1.XX and subnet mask to 255.255.255.0.
2. Run Mindray Patient Monitor Software Upgrade Tool on the PC and set Machine to **[iMEC]**.
3. On the Mindray Patient Monitor Software Upgrade Tool screen, select **[Select Package]** and then the packages you want to upgrade. Then select **[Start]**.
4. Start up the patient monitor and press the **[Silence]** + **[Main Menu]** hardkeys quickly to enter upgrade mode. Determine if the software is upgraded successfully according to the prompt message of the patient monitor when finishing upgrading the software.

Software upgrade is taken in the sequence of LINUX kernel (including drive) → system software package (including system software, language library, BMP resource files, and boot program) → Module software.

When software upgrade is finished, restart the patient monitor and check if the software is correctly upgrade.

For details of software upgrade, please refer to the *Instructions For Use* and *Help* of *Mindray Patient Monitor Software Upgrade Tool* or consult our service personnel.

---

 **CAUTION**

---

- **Disconnect the equipment from the patient and make sure the important data are saved before upgrade.**
  - **Do not shut down or power off the equipment when upgrading the boot software. Otherwise, it may cause the equipment to break down.**
  - **Software upgrade should be performed by qualified service personnel only.**
- 

**NOTE**

---

- **Make sure the version of the upgrade package is what you desired. To obtain the latest upgrade package, please contact Mindray Customer Service Department.**
-

# 5 Testing and Maintenance

---

## 5.1 Introduction

To ensure the patient monitor always functions normally, qualified service personnel should perform regular inspection, maintenance and test. This chapter provides a checklist of the testing procedures for the patient monitor with recommended test equipments and frequency. The service personnel should perform the testing and maintenance procedures as required and use appropriate test equipments.

The testing procedures provided in this chapter are intended to verify that the patient monitor meets the performance specifications. If the patient monitor or a module fails to perform as specified in any test, repairs or replacements must be done to correct the problem. If you have any question, contact our Customer Service Department.

---

### CAUTION

- **All tests should be performed by qualified service personnel only.**
  - **Care should be taken to change the settings in [User Maintenance] and [Factory Maintenance] menus to avoid loss of data.**
  - **Service personnel should acquaint themselves with the test tools and make sure that test tools and cables are applicable.**
- 

### 5.1.1 Test Equipment

See the following sections.

### 5.1.2 Test Report

Upon the completion of the tests, the table of preventative maintenance test reports and the table of maintenance test reports in this chapter should be kept properly.

### 5.1.3 Preventative Maintenance

Below are preventative maintenance tests which need to be performed on the monitor. The recommended frequency of preventative maintenance is at least once per year. See the following sections for detailed maintenance procedures.

- Visual inspection
- NIBP test
- CO<sub>2</sub> test and calibration

### 5.1.4 Recommended Frequency

Check/Maintenance Item		Frequency
Visual inspection		1. When first installed or reinstalled.
Power-on test		1. When first installed or reinstalled. 2. Following any repairs or replacement of any main unit parts.
ECG test	Performance Test	1. If the user suspects that the measurement is incorrect. 2. Following any repairs or replacement of relevant module. 3. At least once every two years. Note: At least once a year is recommended for NIBP and CO <sub>2</sub> .
	Calibration	
Resp performance test		
SpO <sub>2</sub> test		
NIBP test	Pressure check	
	Leakage test	
TEMP test		
IBP test	Performance test	
	Pressure calibration	
C.O. test		
Mainstream CO <sub>2</sub> test		
Sidestream and Microstream CO <sub>2</sub> tests	Leakage test	
	Performance test	
	Calibration	
Nurse call function test		
Analog output performance test		
Electric Safety Tests	Refer to <b>A Electrical Safety Inspection.</b>	1. Following any repair or replacement. 2. After the monitor drops. 3. At least once every two years.
Touchscreen calibration		1. When the touchscreen appears abnormal. 2. After the touchscreen is replaced.
Recorder check		Following any repair or replacement of the recorder.
Battery check	Functionality test	1. When first installed. 2. Whenever a battery is replaced.
	Performance test	Once every six months or if the battery run time reduced significantly.

## 5.2 Visual Inspection

Inspect the equipment for obvious signs of damage. The test is passed if the equipment has no obvious signs of damage. Following these guidelines when inspecting the equipment:

- Carefully inspect the case, display screen, buttons, and knob for obvious signs of damage.
- Inspect the power cord, wall mount, and accessories for obvious signs of damage.
- Inspect all external connections for loose connectors, bent pins or frayed cables.
- Inspect all connectors on the equipment for loose connectors or bent pins.
- Make sure that safety labels and data plates on the equipment are clearly legible.

## 5.3 Power-on Test

This test is to verify that the patient monitor can power up correctly. The test is passed if the patient monitor starts up by following this procedure:

1. Insert the battery in the battery compartment and connect the patient monitor to the AC mains. The AC mains LED and battery LED light.
2. Press the power on/off switch to switch on the patient monitor.

The monitor performs self-test as soon as the monitor is powered on. During the self-test, the alarm lamp turns yellow and red, and then turns off; the monitor gives a beep. This indicates that the visual and audible alarm indicators operate properly.

## 5.4 Module Performance Tests

### 5.4.1 ECG Test and Calibration

#### ECG Performance Test

Tool required:

- Fluke Medsim 300B patient simulator recommended
1. Connect the patient simulator with the ECG connector using an ECG cable.
  2. Set the patient simulator as follows: ECG sinus rhythm, HR = 80 bpm with the amplitude as 1mV.
  3. Check the ECG waves are displayed correctly without noise and the displayed HR value is within  $80 \pm 1$  bpm.
  4. Disconnect each of the leads in turn and observe the corresponding lead off message displayed on the screen.
  5. Set the simulator outputs paced signals and set **[Paced]** to **[Yes]** on the monitor. Check the pace pulse marks on the monitor screen.

## ECG Calibration

Tool required:

- Vernier caliper

1. Select the ECG parameter window or waveform area and set **[Filter]** to **[Diagnostic]**.
2. Select **[Main Menu]** → **[Maintenance >>]**.
3. Select **[Calibrate ECG]**. A square wave appears on the screen and the message **[ECG calibrating]** is displayed.
4. Compare the amplitude of the square wave with the wave scale. The difference should be within 5%.
5. After completing the calibration, select **[Stop Calibrating ECG]**.

You can print out the square wave and wave scale and then measure the difference between them if necessary.

### 5.4.2 Resp Test

Tool required:

- Fluke Medsim 300B patient simulator recommended

1. Connect the patient simulator to the module using a non ESU-proof cable and set lead II as the respiration lead.
2. Configure the simulator as follows: lead II as the respiration lead, base impedance line as 1500  $\Omega$ , data impedance as 0.5  $\Omega$ , and respiration rate as 40 rpm.
3. Check the Resp wave is displayed without any distortion and the displayed Resp value is within  $40 \pm 2$  rpm.

### 5.4.3 SpO<sub>2</sub> Test

Tool required:

- None

1. Connect SpO<sub>2</sub> sensor to the SpO<sub>2</sub> connector of the monitor. Set **[Patient Cat.]** to **[Adu]** and **[PR Source]** to **[SpO2]**.
2. Apply the SpO<sub>2</sub> sensor to your ring finger (assume that you stay healthy).
3. Check the Pleth wave and PR reading on the screen and make sure that the displayed SpO<sub>2</sub> is within 95% and 100%.
4. Remove the SpO<sub>2</sub> sensor from your finger and make sure that an alarm of SpO<sub>2</sub> Sensor Off is triggered.

Measurement validation:

The accuracy of Mindray SpO<sub>2</sub> board has been validated in human studies against arterial blood sample reference measured with a CO-oximeter. Pulse oximeter measurements are statistically distributed, and only about two-thirds of the measurements can be expected to fall within the specified accuracy compared to CO-oximeter measurements.

## NOTE

---

- A functional tester cannot be used to assess the accuracy of a pulse oximeter monitor. However, it can be used to demonstrate that a particular pulse oximeter monitor reproduces a calibration curve that has been independently demonstrated to fulfill a particular accuracy specification.
- 

### 5.4.4 NIBP Test

#### NIBP Leakage Test

## NOTE

---

- Perform NIBP leakage test before any other NIBP concerned test.
- 

Tools required:

- NIBP cuff for adult patient
- Appropriate tubing
- Cylinder

Follow this procedure to perform the leakage test:

1. Set **[Patient Cat.]** to **[Adu]**.
2. Connect the NIBP cuff to the NIBP connector on the monitor.
3. Apply the cuff to the cylinder as shown below.

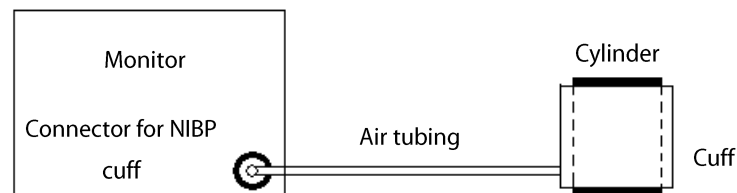

4. Select **[Main Menu]** → **[Maintenance >>]** → **[NIBP Leakage Test]**. The message **[Leakage Testing...]** is displayed in the NIBP parameter area.
5. The cuff automatically deflates after 20 s, which means NIBP leakage test is completed.
6. If no message is displayed in the NIBP parameter area, it indicates that the system has no leakage. If the message **[NIBP Pneumatic Leak]** is displayed, it indicates that the system may have a leakage. In this case, check if all connections are good and the cuff and tubing have no leakage. Perform the test again after making sure all connections are good and the cuff and tubing have no leakage.

You can either perform a manual leakage test:

1. Perform steps 1 to 4 in the NIBP Accuracy Test section.
2. Raise the pressure in the rigid vessel to 250 mmHg with the balloon pump. Then, wait for 5 seconds to let the measured values becoming stable.
3. Record the current pressure value, and meanwhile use a time counter to count the time. Then, record the pressure value after 60 s.
4. Compare the two pressure values and make sure the difference should not be greater than 6 mmHg.

### NIBP Accuracy Test

Tools required:

- T-shape connector
- Appropriate tubing
- Balloon pump
- Rigid Vessel with volume  $500 \pm 25$  ml
- Reference manometer (calibrated with accuracy equal to or better than 0.75 mmHg)

Follow this procedure to perform the accuracy test:

1. Connect the equipments as shown below.

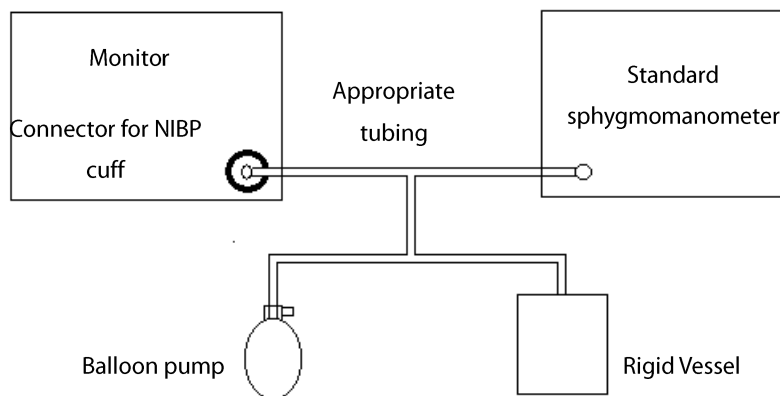

2. Before inflation, check that the reading of the manometer is 0. If not, turn off the balloon pump to let the whole airway open to the atmosphere. Turn on the balloon pump after the reading is 0.
3. Select **[Main Menu]** → **[Maintenance >>]** → **[NIBP Accuracy Test]**.
4. Check the manometer values and the monitor values. Both should be 0 mmHg.
5. Raise the pressure in the rigid vessel to 50 mmHg with the balloon pump. Then, wait for 10 seconds to let the measured values become stable.
6. Compare the manometer values with the monitor values. The difference between the manometer and displayed values should be  $\pm 3$  mmHg. If it is greater than  $\pm 3$  mmHg.
7. Raise the pressure in the rigid vessel to 200 mmHg with the balloon pump. Then, wait for 10 seconds to let the measured values become stable. Repeat step 6.



## NOTE

---

- You can use an NIBP simulator to replace the balloon pump and the reference manometer to perform the test.
  - You can use an appropriate cylinder and a cuff instead of the rigid vessel.
- 

### 5.4.5 Temp Test

Tool required:

- Resistance box (with accuracy above 0.1  $\Omega$ )
1. Connect the two pins of any Temp connector in the monitor to the two ends of the resistance box using 2 wires.
  2. Set the resistance box to 1354.9  $\Omega$  (corresponding temperature is 37 °C).
  3. Verify each Temp channel of the monitor and make sure that the displayed value is within  $37 \pm 0.1$  °C.
  4. Repeat steps 1 to 3 and verify another temperature channel.

### 5.4.6 IBP Test and Calibration

#### IBP Performance Test

Tools required:

- Medsim300B patient simulator, or MPS450, or equivalent equipments
  - IBP adapter cable for test (P/N 00-002199-00 for Medsim 300B, P/N 00-002198-00, for MPS450)
1. Connect the patient simulator through the monitor's IBP connector.
  2. Make the patient simulator outputs 0 mmHg to an IBP channel.
  3. Select IBP Zero in the IBP setup Menu to make a zero calibration.
  4. Set the patient simulator as P (static) = 200 mmHg.
  5. The displayed value should be within  $200 \pm 4$  mmHg.
  6. If the error is beyond  $\pm 4$  mmHg, calibrate the pressure module. If the IBP module was calibrated with a dedicated reusable IBP sensor, check the calibration together with this IBP sensor.
  7. Let the patient simulator output 120/80 mmHg ART signal and 120/0 mmHg LV signal to the IBP channel and check that the IBP wave is displayed correctly.
  8. Repeat the steps above to calibrate other IBP channels.

#### IBP Pressure Calibration

Method 1:

Tools required:

- Medsim300B patient simulator, or MPS450, or equivalent equipments
- IBP adapter cable for test (P/N 00-002199-00 for Medsim 300B, P/N 00-002198-00, for MPS450)

1. Connect the patient simulator through the monitor's IBP connector.
2. Set the patient simulator to 0 for the desired IBP channel.
3. Select IBP Zero in the IBP setup Menu to make a zero calibration.
4. Set the patient simulator as P (static) = 200 mmHg.
5. Select **[Main Menu]** → **[Maintenance >>]** → **[Cal. IBP Press. >>]**. In the **[Cal. IBP Press.]** menu, set the calibration value to 200 mmHg.
6. Select the **[Calibrate]** button next to the desired IBP channel to start calibration.
7. If the calibration is completed successfully, the message **[Calibration Completed!]** will be displayed. Otherwise, a corresponding message will be displayed.

Method 2:

Tools required:

- Standard sphygmomanometer
- Balloon pump
- Appropriate tubing
- T-shape connector

1. Connect the 3-way stopcock, the sphygmomanometer and the balloon pump through a T-shape connector, as shown below.

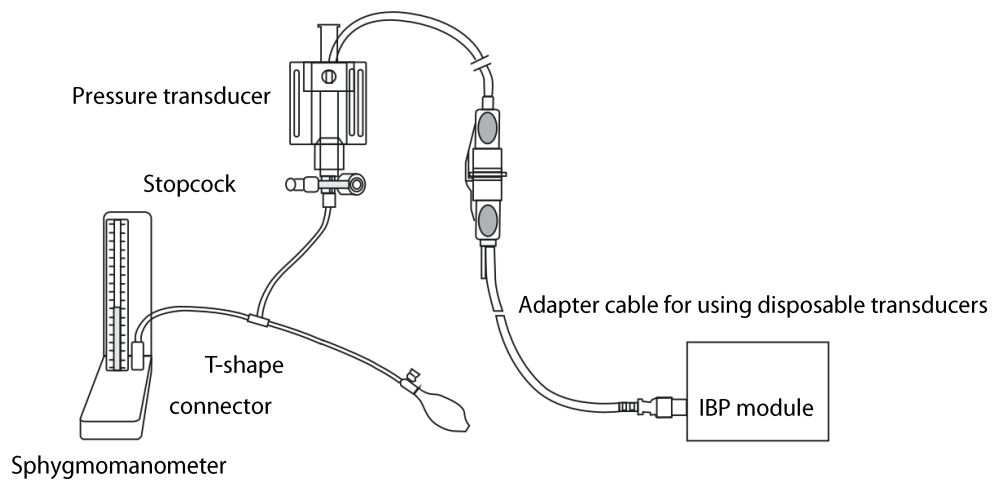

2. Vent the transducer to the atmospheric pressure by turning on the 3-way stopcock to the air. Zero the transducer, and then open the stopcock to the sphygmomanometer.
3. Select **[Main Menu]** → **[Maintenance >>]** → **[Cal. IBP Press. >>]**. In the **[Cal. IBP Press.]** menu, configure the IBP calibration value.
4. Inflate using the balloon pump until the reading of sphygmomanometer approximates the preset calibration value.
5. Adjust the preset calibration value until it equals to the reading of the sphygmomanometer.
6. Select the **[Calibrate]** button next to the desired IBP channel to start calibration.

When the calibration is completed, the message **[Calibration Completed!]** will be displayed. Otherwise, a corresponding message will be displayed.

### 5.4.7 C.O. Test

Tools required:

- Medsim300B patient simulator, or MPS450, or equivalent equipments
  - C.O. adapter box ( CI-3 module/cable, P/N: 3010-0289 for 300B; P/N: 5180500 for MPS450)
  - C.O. trunk cable (P/N: 0010-21-42716)
1. Connect the patient simulator to the C.O. connector on the patient monitor using a C.O. trunk cable and a C.O. adapter box.
  2. Set the blood pressure (BT) to 37 °C on the patient simulator and check that the temperature value displayed on the monitor is within  $37 \pm 0.2$  °C.
  3. In the **[C.O. Setup]** menu on the patient monitor, set **[Auto TI]** to **[Off]**, **[Manual TI (°C)]** to 2 °C, and **[Comp. Const.]** to 0.542. Select **[C.O. Measure]** to enter the C.O. measurement window.
  4. Select **[Start]** in the C.O. measurement window to start C.O. measurement.
  5. On the patient simulator, set C.O. to 5 L/min and wait for 3 to 10 seconds.
  6. Verify that the C.O. value displayed on the monitor is  $5 \pm 0.25$  L/min.

### 5.4.8 Mainstream CO<sub>2</sub> Tests

#### NOTE

---

- **before performing CO<sub>2</sub> tests, select [Main Menu] → [Maintenance >>] → [User Maintenance] → enter the required password → [Maintain CO<sub>2</sub>], and make sure that the setting of [Barometric Pressure] is correct.**
- 

Tools required:

- A steel gas cylinder with  $6 \pm 0.05\%$  CO<sub>2</sub> and balance gas N<sub>2</sub>
  - A steel gas cylinder with 100% N<sub>2</sub>
  - T-shape connector
  - Appropriate tubing
  - Flowmeter
1. Connect the sensor.
  2. Wait for 10 seconds until the CO<sub>2</sub> warmup is finished and then in the **[CO<sub>2</sub> Setup]** menu, select **[Start Zero Cal.]** to start a zero calibration. If the calibration fails, the prompt message **[CO<sub>2</sub> Zero Failed]** is displayed. Otherwise, the baseline of waveform recovers to zero.
  3. In the **[CO<sub>2</sub> Setup]** menu, set **[Apnea Delay]** to 10 s.
  4. Blow to the CO<sub>2</sub> sensor to generate a CO<sub>2</sub> waveform and then place the sensor in the air. Check if the alarm message **[CO<sub>2</sub> Apnea]** is displayed on the screen.

5. Connect the test system as follows:

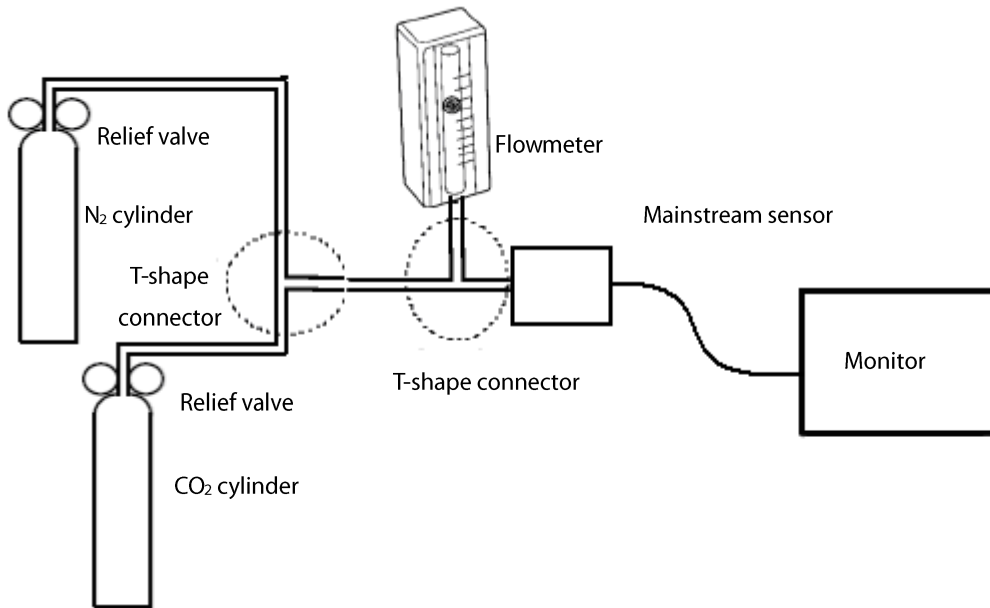

6. Adjust the power supply and turn on/off 3-way valves to ensure that only one cylinder is connected to the Mainstream CO<sub>2</sub> sensor via the 3-way valves at one time.
7. Adjust the relief valve and make sure the flowmeter reading is stable and within 2 and 5 L/min.
8. Switch between the two cylinders to connect Mainstream CO<sub>2</sub> sensor at an intervals of 6 to 10s and check if the displayed CO<sub>2</sub> value is within  $45 \pm 2$  mmHg.

### 5.4.9 Sidestream and Microstream CO<sub>2</sub> Tests and Calibration

#### Leakage Test

1. Connect the CO<sub>2</sub> module with the patient module.
2. Wait for 10 seconds until CO<sub>2</sub> warmup is finished, and then use your hand or other objects to completely block the gas inlet of the module or watertrap. The sidestream and microstream CO<sub>2</sub> modules will behave as follows:
  - ◆ Sidestream: the alarm message **[CO<sub>2</sub> Filter Line Err]** is displayed on the screen after 3 seconds. Block the gas inlet for another 60 seconds, and select **[User Maintenance >>]** → enter the required password → **[Maintain CO<sub>2</sub> >>]** → **[Calibrate CO<sub>2</sub> >>]** and check that the current CO<sub>2</sub> flow is less than 10ml/min. If the alarm message continues, it indicates that the module does not leak.
  - ◆ Microstream: The alarm message **[CO<sub>2</sub> Purging]** is displayed on the screen after 3 seconds. Block the gas inlet for another 40 seconds. If alarm message **[CO<sub>2</sub> Filter Line Err]** is displayed, it indicates that the module does not leak.

## Accuracy Test

Tools required:

- A steel gas cylinder with  $6 \pm 0.05\%$  CO<sub>2</sub> and balance gas N<sub>2</sub>
- T-shape connector
- Appropriate tubing
- Flowmeter

1. Connect the CO<sub>2</sub> module with the patient module.
2. Wait for 10 minutes until the CO<sub>2</sub> warmup is finished, and check the airway for leakage and perform a leakage test as well to make sure the airway has no leakage.
3. Select [**User Maintenance >>**] → enter the required password → [**Maintain CO2 >>**] → [**Calibrate CO2 >>**].
4. Connect the test system as follows:

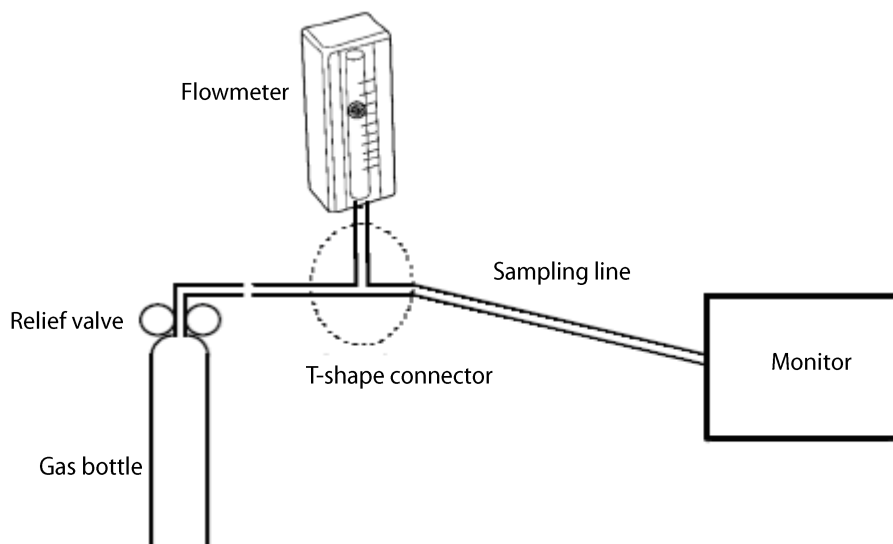

5. Adjust the relief valve and make sure the flowmeter reading is stable and within 10 and 50 L/min.
6. Check the realtime CO<sub>2</sub> value is within  $6 \pm 0.3\%$  in the [**Calibrate CO2**] menu.

## Calibration

Tools required:

- A steel gas cylinder with  $6 \pm 0.05\%$  CO<sub>2</sub> and balance gas N<sub>2</sub>
- T-shape connector
- Appropriate tubing

1. Make sure that the sidestream CO<sub>2</sub> module or microstream CO<sub>2</sub> module has been warmed up or started up.
2. Check the airway for leakage and perform a leakage test as well to make sure the airway has no leakage.
3. Select [**Main Menu**] → [**Maintenance >>**] → [**User Maintenance >>**] → enter the required password → [**Maintain CO2 >>**] → [**Calibrate CO2 >>**] to enter the [**Calibrate CO2**] menu.
4. Then select [**Zero**].

5. After the zero calibration is finished successfully, connect the equipment as follows:

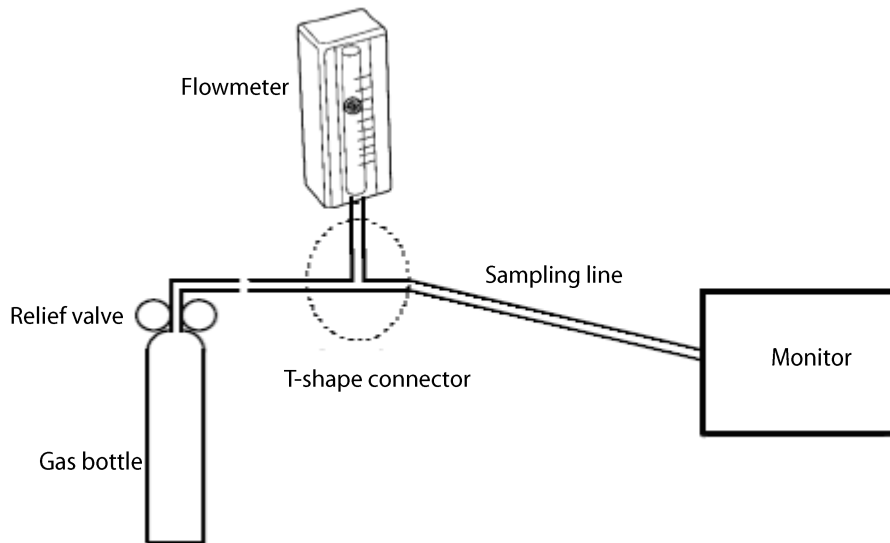

6. Adjust the relief valve and make sure the flowmeter reading is stable and within 10 and 50 L/min.
7. In the [**Calibrate CO2**] menu, enter the vented CO<sub>2</sub> concentration in the [**CO2**] field.
8. In the [**Calibrate CO2**], the measured CO<sub>2</sub> concentration is displayed. After the measured CO<sub>2</sub> concentration becomes stable, select [**Calibrate CO2**] to calibrate the CO<sub>2</sub> module.
9. If the calibration is finished successfully, the message [**Calibration Completed!**] is displayed in the [**Calibrate CO2**] menu. If the calibration failed, the message [**Calibration Failed**] is displayed. In this case, perform another calibration.

## 5.4.10 AG Tests

### AG Leakage Test

The AG leakage test is required every time before the AG measurement. Follow this procedure to perform the test:

1. Plug the AG module into the module rack.
2. Wait for more than 10 mins until the AG module warmup is finished and then use your hand or other objects to completely block the gas inlet of the AG module. An alarm message [**AG Airway Occluded**] will appear on the screen.
3. Block the gas inlet for another 30 s. Select [**Main Menu**] → [**Maintenance >>**] → [**User Maintenance >>**] → enter the required password → [**Module Maintenance >>**] → [**Calibrate AG >>**].

Check that the current flow rate is less than 10ml/min, and the alarm message [**AG Airway Occluded**] does not disappear. This indicates that the module does not leak.

If the alarm message disappears, or the flow rate is equal to or greater, it indicates that the module leaks. Perform the leakage test again. If the problem remains, contact your service personnel for help.

## AG Accuracy Test

Tools required:

- Gas cylinder with 100% O<sub>2</sub> and/or a certain standard gas (such as 6±0.05% CO<sub>2</sub>, Bal N<sub>2</sub>), or standard gas mixture (such as 5±0.03% CO<sub>2</sub>, 1.5±0.15% ISO, 45±0.23% O<sub>2</sub> bal N<sub>2</sub>O).
- Gas concentration should meet the following requirements respectively: AA≥1.5%, CO<sub>2</sub>≥1.5%, N<sub>2</sub>O≥40%, O<sub>2</sub>≥40%, of which AA represents an anaesthetic agent. The gas concentration accuracy should have a tolerance as follows: AA±0.15%, CO<sub>2</sub>±0.1%, N<sub>2</sub>O±1%, O<sub>2</sub>±1%.
- T-shape connector
- Tubing

## NOTE

- **When testing a particular gas in a mixture, only the concentration of the gas to be tested needs to meet the requirements.**
- **Handle the gas cylinder by following the instructions on the gas cylinder.**

Follow this procedure to perform the test:

1. Plug the AG module into the module rack.
2. Wait at least 10 min and then perform a leakage test to make sure the airway has no leakage.
3. Check if the fan inside the AG module works correctly.
4. Connect the test system as follows:

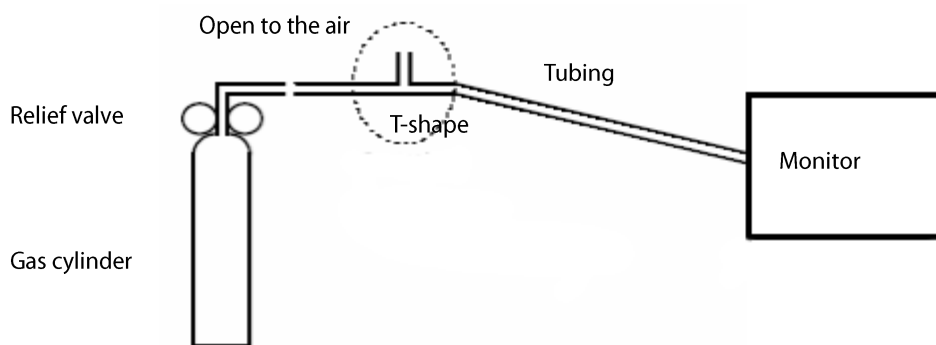

5. Open the relief valve and vent a standard gas and make sure that there is an excess gas flow through the T-shape connector to air. And wait for at least 30 seconds until the gas reading stable.
6. Check that the concentration of each composition meets the specification stated in the Operator's Manual.

---

## WARNING

- **When performing AG accuracy test, be sure to dispose of exhaust gas properly.**
-

## AG Calibration

Tools required:

- Gas cylinder with a certain standard gas or standard gas mixture. Gas concentration should meet the following requirements respectively: AA $\geq$ 1.5%, CO<sub>2</sub> $\geq$ 1.5%, N<sub>2</sub>O $\geq$ 40%, O<sub>2</sub> $\geq$ 40%, of which AA represents an anaesthetic agent. The gas concentration accuracy should have a tolerance as follows: AA $\pm$ 0.15%, CO<sub>2</sub> $\pm$ 0.1%, N<sub>2</sub>O $\pm$ 1%, O<sub>2</sub> $\pm$ 1%.
- T-shape connector
- Tubing

## NOTE

- **When calibrating a particular gas in a mixture, only the concentration of the gas to be calibrated needs to meet the requirements.**
- **Handle the gas cylinder by following the instructions on the gas cylinder(s).**

Follow this procedure to perform the AG calibration:

1. Select **[Main Menu]**→**[Maintenance >>]**→**[User Maintenance >>]**→enter the required password→**[Module Maintenance >>]**→**[Calibrate AG >>]**.
2. Check the airway and make sure that there are no occlusions or leaks.
  - ◆ Vent the sampling tubing to the air and check if the **[Current FlowRate]** and **[SetFlowRate]** are approximately the same. If the deviation is great, it indicates that there is an occlusion in the tubing. Check the tubing for an occlusion.
  - ◆ Perform a leakage test to make sure that the airway has no leakage.
3. Connect the test system as follows:

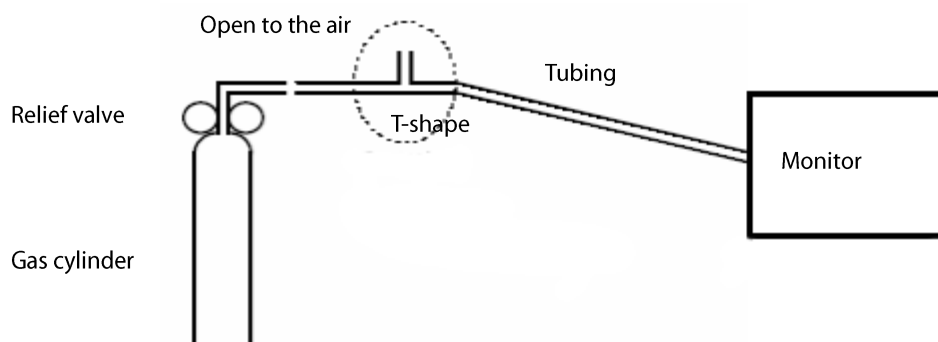

4. Open the relief valve and vent a certain standard gas or gas mixture and make sure that there is an excess gas flow through the T-shape connector to air. And wait for at least 30 seconds until the gas reading stable.
5. In the **[Calibrate AG]** menu, the concentration of each measured gas and flow rate are displayed.
  - ◆ If the difference between the measured gas concentration and the actual one is within the tolerances in the user manual, a calibration is not needed.
  - ◆ If the difference for one gas composition or more gas compositions is outside of the stated tolerances, a calibration for one gas composition or more gas compositions should be performed. Select **[Calibrate >>]** to enter the calibrate menu.



6. Enter the vented gas concentration(s) for one gas composition or more gas compositions which needs calibration. If only one gas composition in gas mixture is to be calibrated i.e. CO<sub>2</sub> only, set the concentration of the other gases to 0.
7. Select [**Start**] to start a calibration.
8. If the calibration is finished successfully, the message [**Calibration Completed!**] is displayed. If the calibration failed, the message [**Calibration Failed!**] is displayed. Perform another calibration.

After the calibration finished, an accuracy test should be performed according to the Accuracy Test chapter. If one gas composition of the gas mixture is outside of the stated tolerances, please perform the calibration for the gas which reading is out of stated tolerances by using the calibration gas cylinder or another calibration gas cylinder following the instruction of Calibration chapter again.

---

---

 **WARNING**

- **When performing AG calibration, be sure to dispose of exhaust gas properly.**
- 
- 

---

---

 **CAUTION**

- **Calibrate the AG module, if it has been transported for a long distance or not used for a prolonged period of time.**
  - **Calibrate the AG module, if the module was subject to physical impact damage i.e. dropped etc. or when the measured value(s) has a great deviation.**
  - **It is not recommended to calibrate the anaesthetic agents (Halothane, Isoflurane, Enflurane, Sevoflurane and Desflurane) for AG user calibration. If the gas measurement reading for anaesthetic agents is outside the specification please contact Mindray Medical for advice.**
- 

---

---

**NOTE**

- **For measurement of O<sub>2</sub> concentration more than 80%, it recommends to use gas cylinder with 100% O<sub>2</sub> to do the O<sub>2</sub> calibration again.**
- 

## 5.5 Nurse Call Function Test

Tool required:

- Oscilloscope

1. Connect the nurse call cable to the Multifunctional Connector of the patient monitor.
2. Enter [**Demo**] mode. Then select [**Main Menu**] → [**Maintenance >>**] → [**User Maintenance >>**] → enter the required password → [**Others >>**].

3. In the [Others >>] menu, select [Nurse Call Setup >>] and then in the [Nurse Call Setup] menu, select all optional [Alm Lev] and [Alm Cat.], and set [Contact Type] to [Normally Open].
4. In [Nurse Call Setup >>] menu, set [Signal Type] to [Pulse]. Make the monitor to generate an alarm and check that the oscillograph displays positive pulses of 1s width when there is an alarm.
5. In [Nurse Call Setup >>] menu, set [Signal Type] to [Continuous]. Make the monitor to generate an alarm and check that the oscillograph outputs continuous high level when there is an alarm.

## 5.6 Analog Output Performance Test

Tools required:

- Medsim300B patient simulator, or MPS450, or equivalent equipments
- Oscilloscope

Connect the patient simulator to the monitor using an ECG or IBP cable and connect the oscilloscope to the Multifunctional Connector of the patient monitor. Verify that the waves displayed on the oscilloscope are identical with those displayed on the monitor.



## 5.7 Electric Safety Tests

For the electric safety tests, refer to *A Electrical Safety Inspection*.

## 5.8 Touchscreen calibration

Tool required:

- None

1. Select [Main Menu] → [Maintenance >>] → [Cal. Touchscreen].
2. The  symbol will appear at different positions of the screen.
3. Select, in turn, the central point of the  symbol.
4. After the calibration is completed, the message [Screen Calibration Completed!] is displayed. Select [Ok] to confirm the completion of the calibration.

## 5.9 Recorder check

Tool required:

- None

1. Print ECG waveform. The recorder should print correctly and the printout should be clear.

2. Set the recorder to some problems such as out of paper, etc. the patient monitor should give corresponding prompt messages. After the problem is removed, the recorder should be able to work correctly.
3. Switch automatic alarm recording for each parameter ON and then set each parameter's limit outside set alarm limits. Corresponding alarm recordings should be triggered when parameter alarms occur.

## 5.10 Battery Check

Tool required:

- None

### Functional Test

1. If the patient monitor is installed with a battery, remove the battery first.
2. Verify that the patient monitor works correctly when running powered from an AC source.
3. Insert the battery per the procedures provided in the Operator's Manual.
4. Remove the AC power cord and verify that the patient monitor still works correctly.

### Performance Test

Perform the test by referring to the **Battery** chapter in the Operator's Manual and verify the operating time of the battery meets the product specification.

## 5.11 Factory Maintenance

### 5.11.1 Accessing Factory Maintenance Menu

Select [Main Menu] → [Maintenance >>] → [Factory Maintenance >>] → enter the required password to access the [Factory Maintenance] menu.

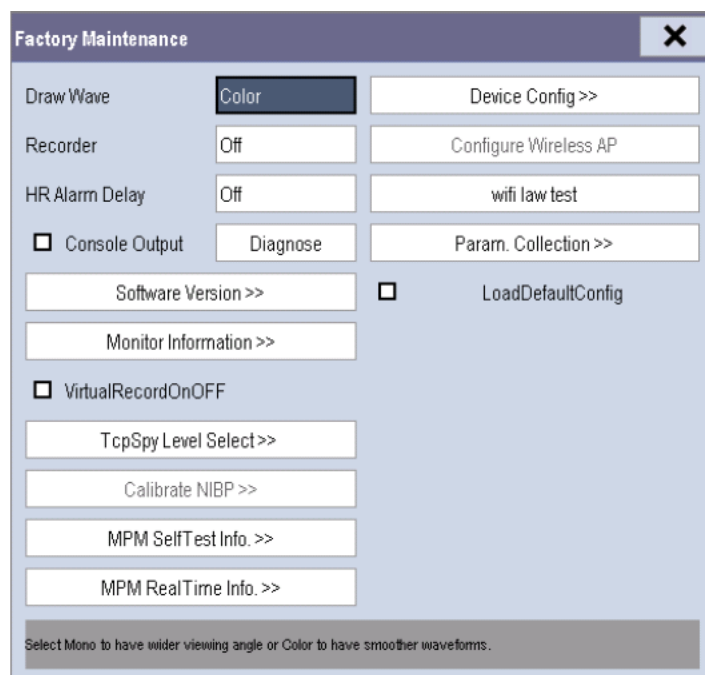

### 5.11.2 Drawing Waves

There are two methods to draw waves: **[Color]** and **[Mono]**.

- Color: selecting Color will have smoother waveforms.
- Mono: selecting Mono will have a wider viewing angle.

### 5.11.3 Recorder

To enable/disable the recorder, select **[Recorder]** and toggle between **[On]** and **[Off]**.

#### NOTE

- The recorder is disabled if **[Recorder]** is set to **[Off]** in the **[Factory Maintenance]** menu.

### 5.11.4 Software Version

Selecting the **[Software Version >>]** will show software version information, as shown below:

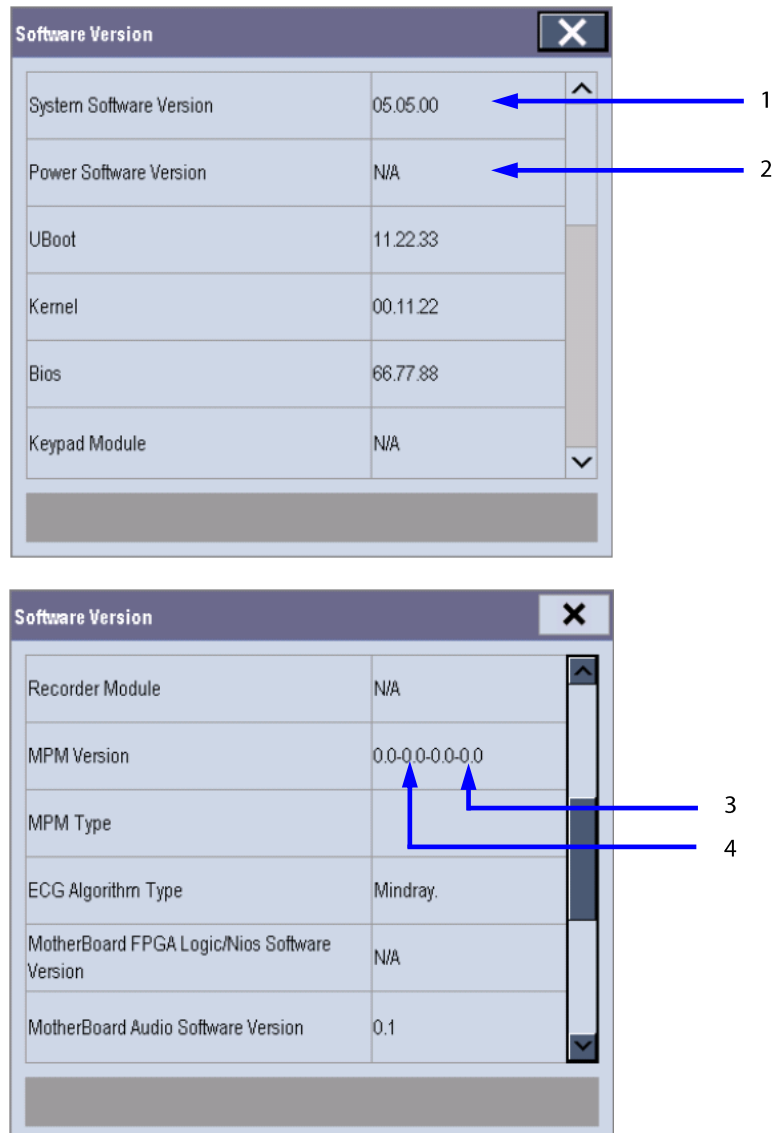

Software Version	
IMR Nios Module FPGA Logic/Nios Software Version	N/A
SMR Nios Module FPGA Logic/Nios Software Version	N/A
External Module Interface Board Version	N/A
Language Library Version	08.04.00
Icon Library Version	08.03.00
Logo Library Version	04.-0.0-

In the above figure,

1. System software version
2. Power software version
3. SpO<sub>2</sub> software version (0.0 indicates that the monitor is equipped with Nellcor or Masimo SpO<sub>2</sub> board)
4. MPM software version

### 5.11.5 Monitor information recording

Selecting [**Monitor Information >>**] will show the status of the patient monitor as shown below:

Monitor Information	
Total Runtime	1Days0Hours35Minutes
CPU PCB/BOM Version	051-000964-00,01
CPU ID	12345678901234
MotherBoard PCB/BOM	N/A
IMR Nios Module PCB/BOM Version	N/A

Electronic SN setup >>

#### NOTE

- If the main board is replaced, you need to check the label on the main unit and reconfigure the serial number of the patient monitor.

**Maintenance and Test Report**

(See the above sections for detailed test procedures and contents)

<b>Customer name</b>		
<b>Customer address</b>		
<b>Servicing person</b>		
<b>Servicing company</b>		
<b>Equipment under test (EUT)</b>		
<b>Model of EUT</b>		
<b>SN of EUT</b>		
<b>Hardware version</b>		
<b>Software version</b>		
<b>Test equipment</b>	<b>Model/No.</b>	<b>Effective date of calibration</b>
<b>Test Content</b>	<b>Test Record</b>	<b>Test Result (Pass/Fail)</b>
<b>Visual Inspection</b>		
The case, display screen, buttons, knob, power cord, wall mount, and accessories have no obvious signs of damage.		
The external connecting cables are not frayed and the connector pins are not loose and bent.		
The external connectors are not loose or their pins are not bent.		
The safety labels and data plate are clearly legible.		
<b>Power-on test</b>		
The power-on test is passed. The power indicator and alarm system work correctly and the monitor start up properly.		
<b>Performance test</b>		
<b>ECG performance test and calibration</b>		
ECG waves are displayed correctly without noise and the HR value is within $80 \pm 1$ bpm.		
ECG Lead Off alarm behaves correctly.		
Paced signals are detected and pace pulse marks are displayed when <b>[Paced]</b> is set to <b>[Yes]</b> .		
The difference between the amplitude of the ECG calibration square wave and that of the wave scale is not greater than 5%.		
<b>RESP test</b>		
The Resp wave is not distorted and the Resp value is within $40 \pm 2$ rpm.		
<b>SpO<sub>2</sub> test</b>		

Measure SpO <sub>2</sub> on a healthy person's finger and a Pleth wave and PR value are displayed. The displayed SpO <sub>2</sub> value is within 95% and 100%.		
<b>NIBP test</b>		
The difference is within $\pm 3$ mm when 0, 50 or 200 mmHg is set for NIBP accuracy test.		
There is no leakage with NIBP, or the manual leakage test result does not exceed 6 mmHg/min.		
<b>Temp test</b>		
The value displayed for each Temp channel of the monitor is within $37 \pm 0.1$ °C.		
<b>IBP test and calibration</b>		
The static pressure value displayed for each IBP channel is within $200 \pm 4$ mmHg.		
The ART and LV waves for each IBP channel are displayed correctly.		
<b>C.O. test</b>		
The TB value displayed on the monitor is within $37 \pm 0.2$ °C.		
The displayed C.O. value is within $5 \pm 0.25$ L/min.		
<b>Mainstream CO<sub>2</sub> tests</b>		
The mainstream CO <sub>2</sub> is zeroed successfully and the waveform baseline recovers to zero.		
CO <sub>2</sub> Apnea alarm behaves correctly.		
The displayed CO <sub>2</sub> value is within $6.0 \pm 0.3\%$ .		
<b>Mainstream CO<sub>2</sub> tests</b>		
Block the gas inlet of the module or watertrap. The sidestream CO <sub>2</sub> flowrate is slower than 10ml/min and an alarm of CO <sub>2</sub> Filter Line Err is given. It indicates that there is no leakage.		
The displayed CO <sub>2</sub> value is within $6.0 \pm 0.3\%$ .		
<b>Mainstream CO<sub>2</sub> tests</b>		
Block the gas inlet of the module or watertrap for 40s. An alarm of CO <sub>2</sub> Filter Line Err is given. It indicates that there is no leakage.		
The displayed CO <sub>2</sub> value is within $6.0 \pm 0.3\%$ .		
<b>Nurse Call Function Test</b>		
When an alarm is reported on the patient monitor, a nurse call is sent out through the cable.		
<b>Analog output performance test</b>		
The waves displayed on the oscillograph are identical with those displayed on the monitor.		
<b>Electric safety tests</b>		
Refer to <b>A Electrical Safety Inspection</b> . All the electrical safety tests should be passed.		
<b>Touchscreen calibration</b>		
The touchscreen is calibrated successfully.		

<b>Recorder check</b>		
The recorder can print ECG waves correctly and the printout is clear.		
Set the recorder to some problems such as out of paper, etc. the patient monitor gives corresponding prompt messages. After the problem is removed, the recorder is able to work correctly.		
Automatic alarm recording for each parameter functions correctly when parameter alarms occur.		
<b>Battery check</b>		
The monitor can operate correctly from battery power when an AC power failure accidentally occurs.		
The patient monitor can operate independently on a single battery.		

Test conclusion (Yes No)

Tested by:

Test date:



# 6 Corrective Action

---

## 6.1 Introduction

In this chapter, patient monitor problems are listed along with possible causes and recommended corrective actions. Refer to the tables to check the patient monitor, identify and eliminate the troubles.

The troubles we list here are frequently arisen difficulties and the actions we recommend can correct most problems, but not all of them. For more information on troubleshooting, contact our Customer Service Department.

## 6.2 Part Replacement

Printed circuit boards (PCBs), major parts and components in the patient monitor are replaceable. Once you isolate a PCB you suspect defective, follow the instructions in **7 Disassembly and Repair** to replace the PCB with a known good one and check that the trouble disappears or the patient monitor passes all performance tests. Defective PCB can be sent to us for repair. If the trouble remains, exchange the replacement PCB with the original suspicious PCB and continue troubleshooting as directed in this chapter.

To obtain information on replacement parts or order them, refer to **8 Parts**.

## 6.3 Checking Patient Monitor Status

Some troubleshooting tasks may require you to identify the hardware version and status of your monitor. To check equipment status,

1. Select **[Main Menu]**→**[Maintenance >>]**→**[Monitor Information >>]**. Then you can view the information on system start time, self check, etc.
2. Select **[Main Menu]**→**[Maintenance >>]**→**[Factory Maintenance >>]**→enter the required password→**[Monitor Information >>]**. You can also view the information on the monitor's current status.

## 6.4 Checking Software Version

Some troubleshooting may involve software compatibility. Thus it requires you to know your monitor configuration and software version. For detailed information on version compatibility, please contact our Customer Service Department. To view information on the system configuration and system software version,

1. Select **[Main Menu]**→**[Maintenance >>]**→**[Software Version >>]**. You can also view the information on system software version and module software version.
2. Select **[Main Menu]**→**[Maintenance >>]**→**[Factory Maintenance >>]**→enter the required password→**[Software Version >>]**. You can also view the information on system software version and module software version.

## 6.5 Checking Technical Alarms

Before troubleshooting the patient monitor, check for technical alarm messages. If an alarm message is presented, eliminate the technical alarm first.

For detailed information on technical alarm message, possible cause and corrective action, refer to the patient monitor's Operation Manual.

## 6.6 Troubleshooting Guide

### 6.6.1 Power On/Off Failure

Symptoms	Possible Cause	Corrective Action
The patient monitor fails to start.	AC mains not connected or battery too low	Check that AC mains is properly connected or battery capacity is sufficient.
The AC power indicator, battery indicator, or startup LED does not light or fails.	Power supply protection	Refer to <b>6.6.6 Power Supply Failures</b> .
	Cable defective	1. Check the power switch and the cables between the indicator board and keypad, keypad and main board, power board and interface board, and interface board and main board and see if they are properly connected. 2. Check that the cables and connectors are not damaged.
	Power and LED indicator board defective	Replace the power and LED indicator board.
	Power board defective	Replace the power board.
	The connector board failed.	Replace the connector board.
	The main board failed.	Replace the main board.

### 6.6.2 Display Failures

Symptoms	Possible Cause	Corrective Action
The display is blank or black.	Cable defective	1. Check if the cable between the display and main board and the backlight cable are correctly connected. 2. Check that the cables and connectors are not damaged.
	Main board defective	Replace the main board.
	Display defective	Replace the display.
Images overlapped or distorted	Main board error	Replace the main board, or upgrade the main board with the upgrade software.
	Cable defective	1. Check if the cable between the display and main board and the backlight cable are correctly connected. 2. Check that the cables and connectors are not damaged.
Snows or flashing specks on the display. The display does not function.	Cable defective	1. Check that the cable between the secondary display and the monitor is correctly connected. 2. Check that the cables and connectors are not damaged.
	The connector board failed.	Replace the connector board .

Symptoms	Possible Cause	Corrective Action
	The main board failed.	Replace the main board.
Touchscreen does not respond.	Touchscreen disabled	Check if there is a  symbol displayed above the [Main Menu] quickkey. If yes, press and hold the [Main Menu] quickkey for more than 3 seconds to enable the touchscreen.
	Cable defective	1. Check that the cables between the touchscreen and touchscreen control board, and touchscreen control board and main board are properly connected. 2. Check that the cables and connectors are not loose.
	Touchscreen control board defective	Replace the touchscreen control board
	Touchscreen defective	Replace the touchscreen.
	The main board failed.	Replace the main board.
Touch position invalid	Touchscreen not calibrated	Calibrate the touchscreen.

### 6.6.3 Alarm Lamp Failures

Symptoms	Possible Cause	Corrective Action
The alarm lamp is not lit, extinguished, or the alarm lamp illuminates abnormally.	Cable defective	1. Check that the cable between the alarm lamp board and main board is correctly connected. 2. Check that the cables and connectors are not damaged.
	Alarm lamp board defective	Replace the alarm lamp board
	The main board failed.	Replace the main board.

### 6.6.4 Button and Knob Failures

Symptoms	Possible Cause	Corrective Action
Buttons do not work	Cable defective	1. Check that the cable between the keypad board and main board is correctly connected. 2. Check that the cables and connectors are not damaged.
	Keypad board failure	Replace the keypad board.
Knob does not work	Cable defective	1. Check that the cables between the knob and keypad, and keypad and main board are properly connected. 2. Check that the cables and connectors are not damaged.
	Knob failure	Replace the knob encoder.
	Keypad board failure	Replace the keypad board.

## 6.6.5 Sound Failures

Symptoms	Possible Cause	Corrective Action
No hardkey or knob sound, or hardkey or knob sound abnormal	The key volume is set to zero.	Select <b>[Main Menu]</b> → <b>[Screen Setup &gt;&gt;]</b> → <b>[Key Volume &gt;&gt;]</b> and adjust the key volume to appropriate level.
	Cable defective	1. Check that the cable between the speaker and interface board is properly connected. 2. Check that the cables and connectors are not damaged.
	Speaker defective	Replace the speaker.
	The main board failed.	Replace the main board.
	The connector board failed.	Replace the connector board.
No alarm sound or alarm sound abnormal	The alarm sound is set to zero.	Select <b>[Main Menu]</b> → <b>[Maintenance &gt;&gt;]</b> → <b>[User Maintenance &gt;&gt;]</b> → enter the required password → <b>[Alarm Setup &gt;&gt;]</b> and set the <b>[Minimum Alarm Volume]</b> to appropriate level. Select <b>[Alarm Setup]</b> on the main menu to adjust the alarm volume.
	Cable defective	1. Check that the cable between the speaker and interface board is properly connected. 2. Check that the cables and connectors are not damaged.
	Speaker defective	Replace the speaker.
	The main board failed.	Replace the main board.
	The connector board failed.	Replace the connector board.

## 6.6.6 Power Supply Failures

Symptoms	Possible Cause	Corrective Action
Different battery voltages. Battery cannot be fully charged. Battery cannot be recharged. Battery on-site detection error.	Battery defective	Replace the battery.
	Cable defective	1. Check that the cable between the battery interface board and interface board is properly connected. 2. Check that the cables and connectors are not damaged.
	Battery interface board defective	Replace the battery interface board.
	The interface board failed.	Replace the interface board.
No voltage output from the main lead or the voltage output abnormal.	Cable defective	1. Check that the cables between power board and interface board, and AC inlet and power board are properly connected. 2. Check that the cables and connectors are not damaged.
	Power board defective	Replace the power board.
No +12 V output	1. Power supply protection 2. Power board defective.	1. Turn off the patient monitor and then restart it. 2. If the problem remains, disconnect the AC mains for 5 s and reconnect it. Then restart the patient monitor.
No +5.0 V output		3. If the patient monitor cannot be restarted, replace the power board.

## NOTE

- When the battery module has a failure, it may cause problems to other components, In this case, troubleshoot the battery module per the procedure described in the table above.
- Components of the main unit are powered by the power module. In the event that a component malfunctions, check if the operating voltage is correct.

### 6.6.7 Recorder Failures

Symptoms	Possible Cause	Corrective Action
No printout	Recorder module disabled	1. Check if the recorder status indicator lights. 2. If yes, enable the module in the <b>[Factory Maintenance]</b> menu. Otherwise, check for other possible causes.
	Paper reversed	Re-install the paper roll.
	Cable defective	1. Check that the cable between the recorder and main board is correctly connected. 2. Check that the cables and connectors are not damaged.
	Recorder power supply failure.	Check if the power module outputs 5 V DC and 12 V DC correctly.
	Recorder defective	Replace the recorder.
Poor print quality or paper not feeding properly	Paper roll not properly installed	Stop the recorder and re-install the paper roll.
	Print head dirty	1. Check the thermal print head and the paper roller for foreign matter. 2. Clean the thermal print head with an appropriate clean solution.
	Print head failure	Replace the thermal print head.
	Recorder defective	Replace the recorder.

### 6.6.8 Output Interface Failure

Symptoms	Possible Cause	Corrective Action
No analog out signal	Cable defective	1. Check that the cable between the parameter board and interface board is properly connected. 2. Check that the cables and connectors are not damaged.
	The connector board failed.	Replace the connector board.
	Multi-parameter board failure	Replace the multi-parameter board
USB device does not function (assume that the peripheral devices are good) Unable to use the USB devices USB drive data transfer failure	Cable defective	1. Check that the cable between the interface board and main board is correctly connected. 2. Check that the cables and connectors are not damaged.
	The connector board failed.	Replace the connector board.
	The main board failed.	Replace the main board.
	Improper setup	Select <b>[Main Menu]</b> → <b>[Maintenance &gt;&gt;]</b> → <b>[User Maintenance &gt;&gt;]</b> → enter the required password → <b>[Others &gt;&gt;]</b> and set <b>[Data Transfer Method]</b> to <b>[USB Device]</b> .

### 6.6.9 SD Card Failure

Symptoms	Possible Cause	Corrective Action
Fails to review archived patient data	Abnormal patient admitting	Admit the patient properly.
	SD card full; unavailable for more patient data	Delete garbage patient data, remove the related alarm, and readmit the patient.
	SD card fails	Format the SD card on the patient monitor. Then restart the monitor. If the problem remains, replace the SD card.
	The main board failed.	Replace the main board.

### 6.6.10 Wired Network Related Problems

Symptoms	Possible Cause	Corrective Action
Unable to connect the wired network	Incorrect LAN cable connection	Check LAN cable connection. LAN cable shall not be longer than 50 m.
	Incorrect IP address configuration	Check for IP address conflict. If yes, reconfigure the IP address.
	Cable defective	1. Check that the cable between the interface board and main board is correctly connected. 2. Check that the cables and connectors are not damaged.
	The connector board failed.	Replace the connector board.
	The main board failed.	Replace the main board.
The monitor is frequently off line or disconnects from the network.	Incorrect LAN cable connection	Check LAN cable connection. LAN cable shall not be longer than 50 m.
The patient monitor is connected to a LAN but cannot view other patients under the View Others mode	Incorrect LAN cable connection	Check LAN cable connection. LAN cable shall not be longer than 50 m.
	Excessive requests for viewing the patient monitor at the same time	A patient monitor can only be viewed by 4 other patient monitors at the same time under the View Others mode. The excessive view requests system will be ignored.
	Incorrect IP address configuration	Check for IP address conflict. If yes, reconfigure the IP address.

### 6.6.11 Wi-Fi Related Problems

Symptoms	Possible Cause	Corrective Action
The monitor is frequently off line or disconnects from the Wi-Fi network.	The Wi-Fi signal is unstable in the operating area.	Check the signal quality of the hospital Wi-Fi network.
	The monitor's Wi-Fi antenna is detached or not properly connected to the Wi-Fi module.	Disassemble the monitor and fix the Wi-Fi antenna.
Unable to connect the Wi-Fi network.	Incorrect IP address configuration	Check for IP address conflict. If yes, reconfigure the IP address.
	The Wi-Fi signal is unstable in the operating area.	Check the signal quality of the hospital Wi-Fi network.
	The monitor's Wi-Fi antenna is detached or not connected to the Wi-Fi module.	Fix the Wi-Fi antenna.
	Main board defective	Replace the main board.

### 6.6.12 Software Upgrade Problems

Symptoms	Possible Cause	Corrective Action
Boot file upgrade fails	Power failure or unintended power off during boot file upgrade	Return the main board to factory for repair.
Program upgrade fails	Incorrect network connection	1. Check the network connector on the patient monitor. 2. Make sure that the hub or switch runs normally. Check that net twines are of the right type and have been connected correctly.
	Wrong upgrade package has been downloaded	Select package according to system requirement. Upgrade package shall be .pkg files.
	Incorrect IP address configuration	Configure a fixed IP address for the patient monitor. We recommend not to upgrade a program when the patient monitor is connected to a network with multiple PCs.
Battery abnormal after upgrading the power management program	Fails to power cycle the patient monitor after upgrading the power management program	Upgrade the power management software again and then power cycle the patient monitor.

### 6.6.13 Technical Alarm Messages

Refer to the Operator's Manual.

**FOR YOUR NOTES**



# 7 Disassembly and Repair

---

## 7.1 Tools Required

To disassemble and replace the parts and components, the following tools may be required:

- Philips screwdrivers
- Tweezers
- Sharp nose pliers
- Clamp

## 7.2 Preparations for Disassembly

Before disassembling the equipment, finish the following preparations:

- Stop patient monitoring, turn off the equipment, and disconnect all the accessories and peripheral devices.
- Disconnect the AC power source and remove the battery.



### **WARNING**

- **Before disassembling the equipment, be sure to eliminate the static charges first. When disassembling the parts labeled with static-sensitive symbols, make sure you are wearing electrostatic discharge protection such as antistatic wristband or gloves to avoid damaging the equipment.**
  - **Properly connect and route the cables and wires when reassembling the equipment to avoid short circuit.**
  - **Select appropriate screws to assemble the equipment. If unfit screws are tightened by force, the equipment may be damaged and the screws or part may fall off during use, causing unpredictable equipment damage or human injury.**
  - **Follow correct sequence to disassembly the equipment. Otherwise, the equipment may be damaged permanently.**
  - **Be sure to disconnect all the cables before disassembling any parts. Be sure not to damage any cables or connectors.**
  - **Be sure to place removed screws and disassembled parts properly, preventing them from being lost or contaminated.**
  - **Place the screws and parts from the same module together to facilitate reassembling.**
  - **To reassemble the equipment, first assemble the assemblies, and then the main unit. Carefully route the cables.**
  - **Make sure that the waterproof material is properly applied during reassembling.**
-

## 7.3 Disassembling the Main Unit

---

### NOTE

---

- The recorder can be disassembled separately.
  - To disassemble the equipment, place the equipment on a work surface free from foreign material, avoiding damaging the antiglare screen, touchscreen and the knob. Be careful not to break the two cotters on the front ends of rear housing.
  - All the operations should be performed by qualified service personnel only. Make sure to put on the insulating gloves during service operations.
  - Operations relating to optional parts may not apply to your equipment.
- 

### 7.3.1 Separating the Front and Rear Half of the Monitor

1. Stand the equipment on the work surface. Loose and unscrew the five M4×10 screws as shown below:



2. Separate the front housing assembly and rear housing assembly with caution. Disconnect the cable between the main board and keypad and then take off the front housing.

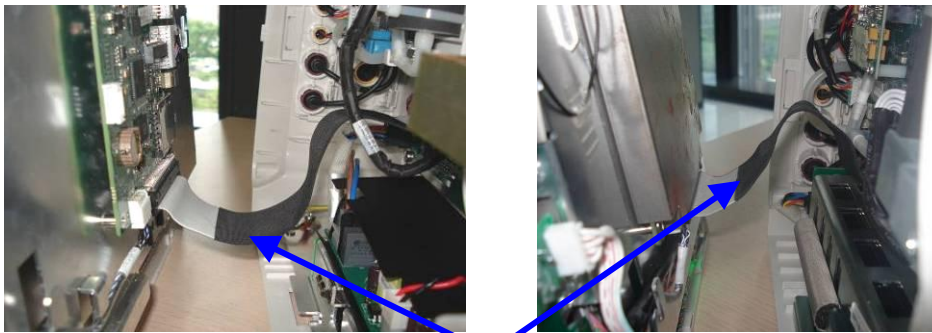

Cable between main board and interface board

(iMEC12/iMEC7/iMEC10/iMEC6)

(iMEC8/iMEC5)

---

### NOTE

---

- When reassembling iMEC12/iMEC7/iMEC10/iMEC6 patient monitors, the cable between the main board and interface board shall be placed downward; when reassembling iMEC8/iMEC5 patient monitors, the cable between main board and interface board shall be placed upward.
-

### 7.3.2 Removing the Parameter Connector Panel Assembly

1. For equipments with standard configuration, the parameter connector assembly can be disassembled separately, as shown below: Disconnect the multi-parameter signal cable, NIBP tube, and ECG signal cable, and then take out the parameter connector assembly along the rear housing.

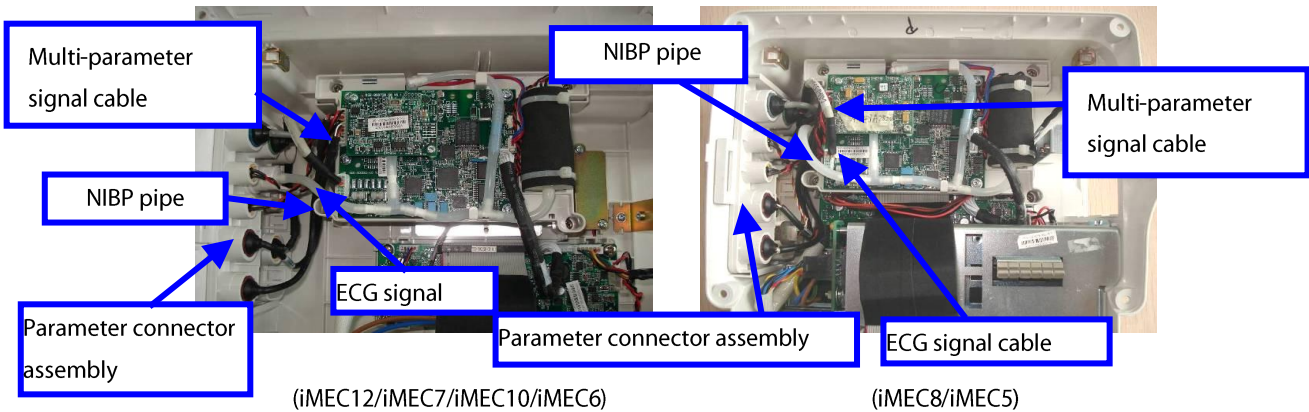

2. For equipments with optional C.O. and CO<sub>2</sub> modules, remove the parameter module assembly as described in **7.3.3 Disassembling the Parameter Module Assembly.**

### 7.3.3 Disassembling the Parameter Module Assembly

1. Lay the equipment on the work surface as shown below, and unscrew the four M4×10 screws:

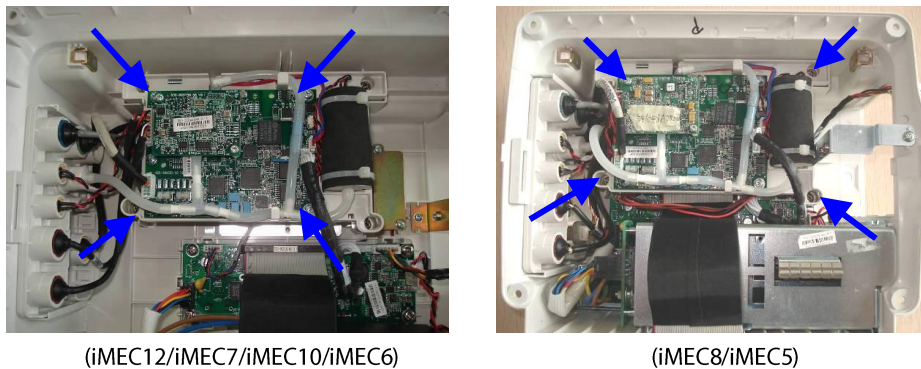

2. Disconnect the multi-parameter signal cable, NIBP pipe, ECG signal cable, the cable between the parameter board and interface board, CO<sub>2</sub> communication cable (optional), and the cable between the interface board and M03B module (optional) respectively, as shown below:

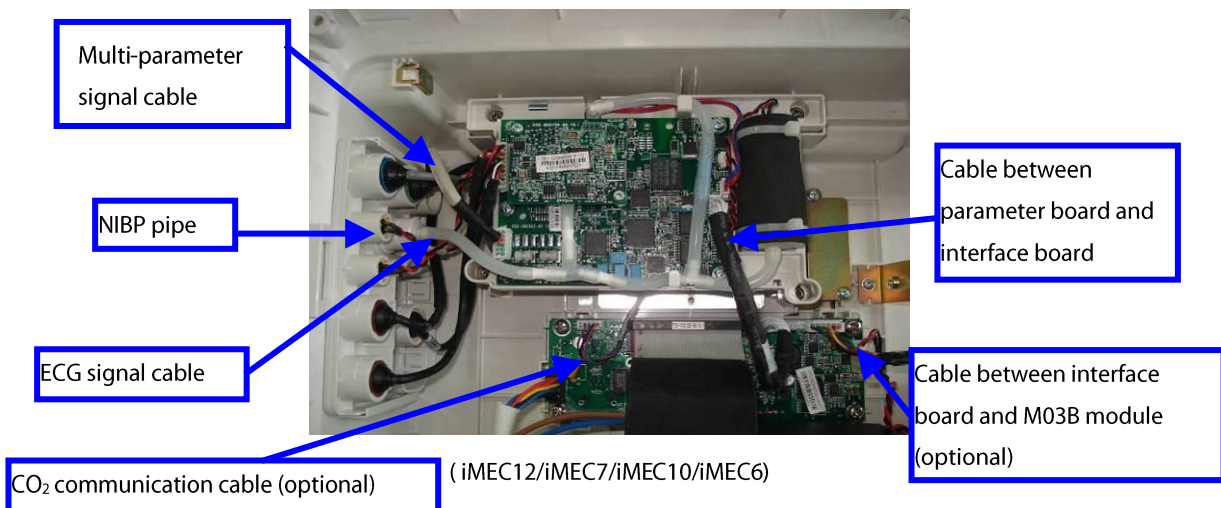

For iMEC8/iMEC5 patient monitors, the power management and interface board is located below the parameter module assembly. Therefore, the correct sequence is: take out the parameter module assembly, and disconnect the CO<sub>2</sub> communication cable (optional) and the cable between interface board M03B module (optional).

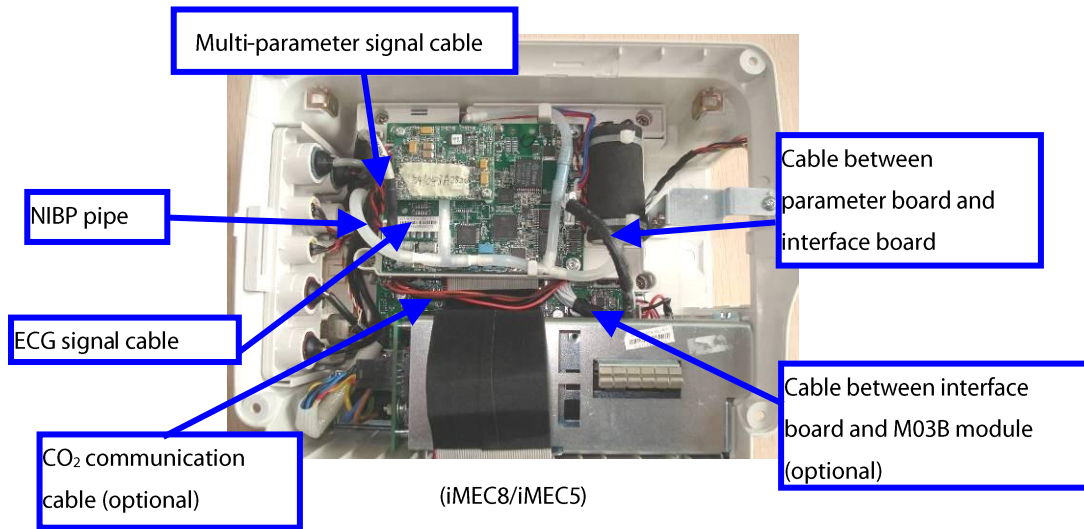

- For equipments with standard configuration, the parameter module assembly can be removed directly.

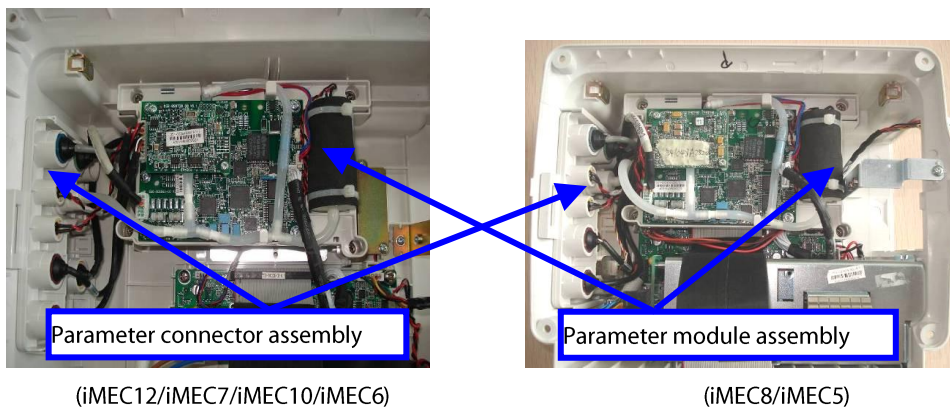

- For equipments with non-standard configurations, take the parameter connector assembly and parameter module assembly out from the rear housing and then separate the two assemblies as per the actual configuration:

**For those configured with C.O. function:** disconnect the C.O. signal cable, and then separate the parameter connector assembly and parameter module assembly, as shown below:

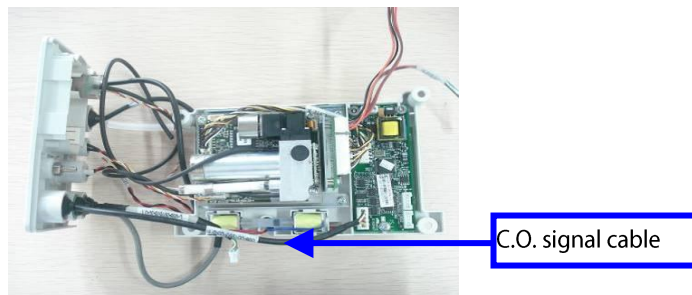

**For those configured with mainstream CO<sub>2</sub>:** disconnect the mainstream CO<sub>2</sub> signal cable, and then separate the parameter connector assembly and parameter module assembly, as shown below:

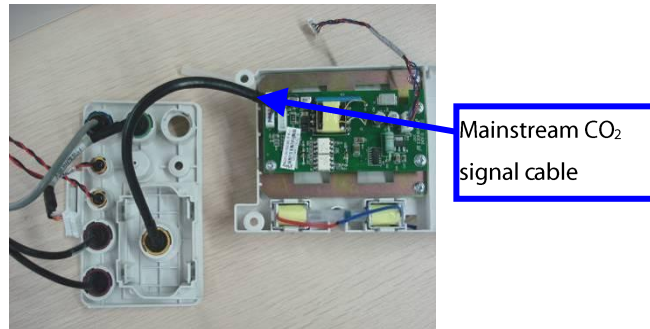

Mainstream CO<sub>2</sub>  
signal cable

**For those configured with microstream CO<sub>2</sub>:** disconnect the CO<sub>2</sub> pipe, take the microstream CO<sub>2</sub> connector assembly out from the parameter connector assembly, and then separate the parameter connector assembly and parameter module assembly, as shown below:

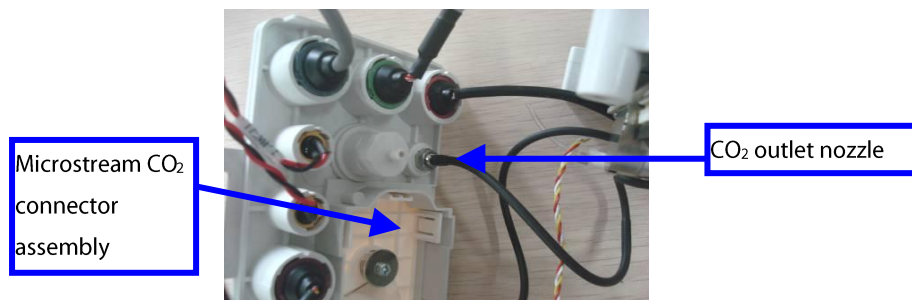

Microstream CO<sub>2</sub>  
connector  
assembly

CO<sub>2</sub> outlet nozzle

**For those configured with Mindray M02C CO<sub>2</sub>:** disconnect the CO<sub>2</sub> pipe, pipe 1, pipe 2, and the cable between the interface board and M02C module respectively, and then separate the parameter connector assembly and the parameter module assembly, as shown below:

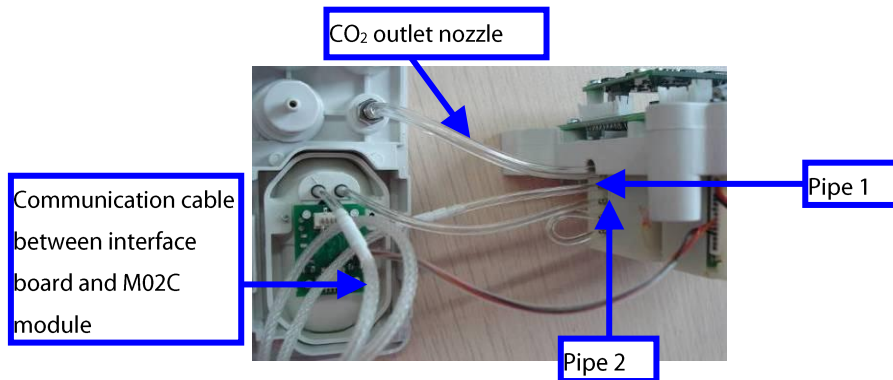

CO<sub>2</sub> outlet nozzle

Communication cable  
between interface  
board and M02C  
module

Pipe 1

Pipe 2

## NOTE

- All pipes should be assembled properly without occlusion during reassembly.
- For equipments configured with optional C.O. or CO<sub>2</sub> modules, be sure to remove the parameter connector assembly and parameter module assembly together from the rear housing and then separate the two module.
- For those with standard configuration, remove the parameter module separately.

### 7.3.4 Removing the Battery Compartment Assembly

#### iMEC12/iMEC7/iMEC10/iMEC6

Loose and unscrew the four M3×6 screws as shown below. Disconnect the cable for battery backboard and cable for AC/DC module, and then remove the battery compartment assembly.

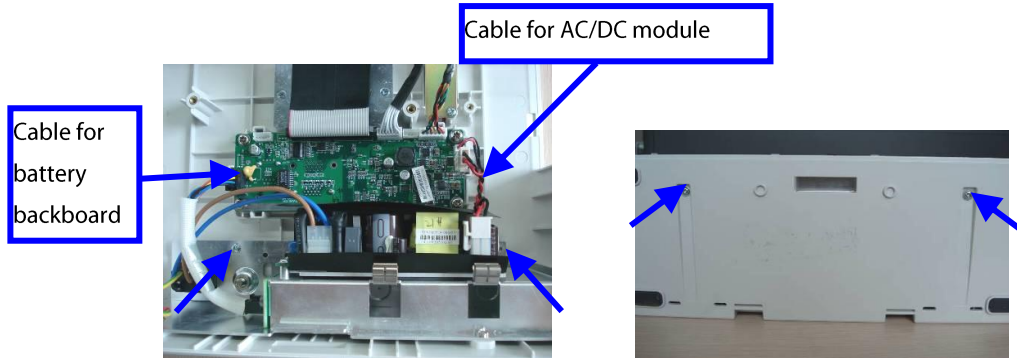

#### iMEC8/iMEC5

Loose and unscrew the M3×6 screw and then the three M3×8 screws as shown below. Disconnect the cable for battery backboard and cable for AC/DC module, and then remove the battery compartment assembly.

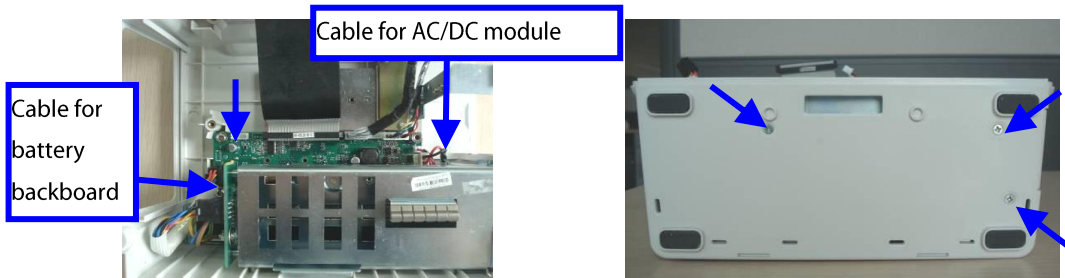

### 7.3.5 Removing the Power Management and Interface Board

#### iMEC12/iMEC7/iMEC10/iMEC6

Unscrew the four M4×10 screws indicated below and unplug the speaker cable, and then remove the power management and interface board.



## iMEC8/iMEC5

Unscrew the three M4×10 screws and then the M4×7+10-5 screw indicated below and unplug the speaker cable, and then remove the power management and interface board.

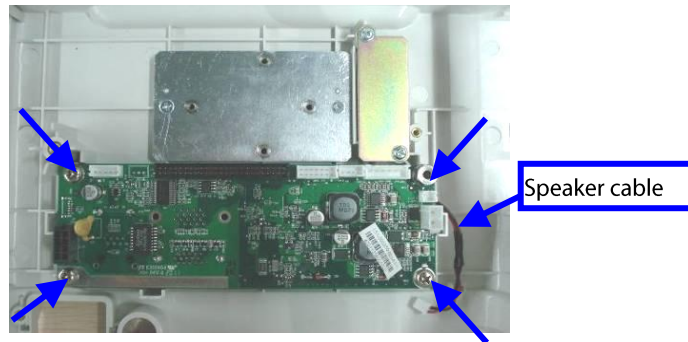

### 7.3.6 Removing the Recorder (Optional)

Unscrew the two M3×6 screws and disconnect the recorder cable to remove the recorder.



#### NOTE

- The recorder can be disassembled separately.

### 7.3.7 Checking Waterproof Strips before Reassembling

#### WARNING

- Before reassembling the equipment, make sure that the waterproof material on the rear housing assembly and power base assembly is stuck to the proper places.

1. Check that the waterproof strip is properly stuck on the battery socket.



2. Check that the white waterproof strip is properly stuck on the front housing assembly.

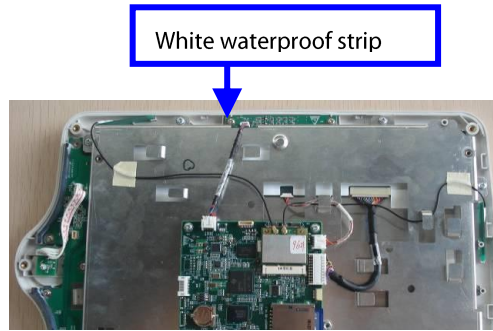

## 7.4 Disassembling the Front Housing Assembly

### NOTE

- To disassemble the equipment, place the equipment on a work surface free from foreign material, avoiding damaging the antiglare screen, touchscreen and the knob.
- Remember to install the screen support pad properly during reassembly.
- Operations relating to optional parts may not apply to your equipment.
- Position the touchscreen properly with the flexible cable facing down.

### 7.4.1 Removing Touchscreen Control Board (Optional)

Loose and unscrew the two M3x8 screws as shown below. Disconnect the touchscreen cable and cable for touchscreen control board, and then remove the touchscreen control board.

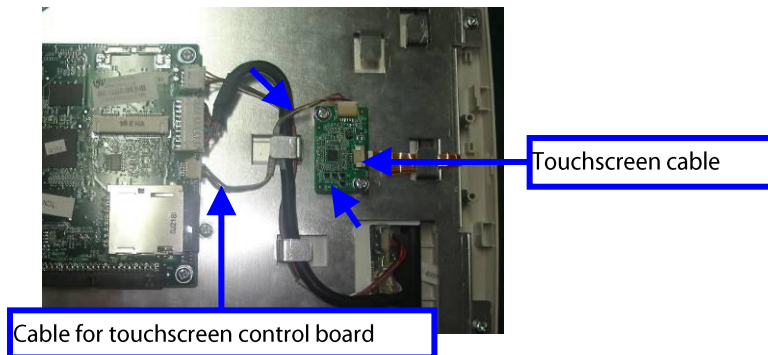



## 7.4.2 Removing Antenna (Optional)

1. Take out the two antennas on the front panel from the slots as shown below:

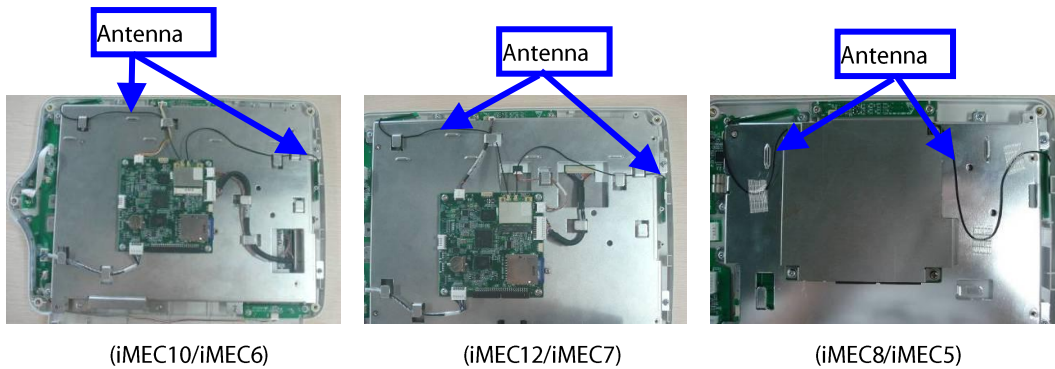

2. Remove the antennas from the Wi-Fi module PCBA.

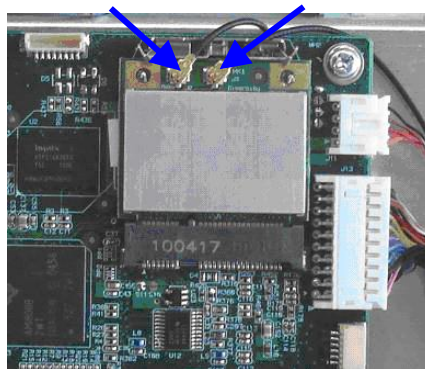

3. Push the clamps aside to remove the Wi-Fi module.

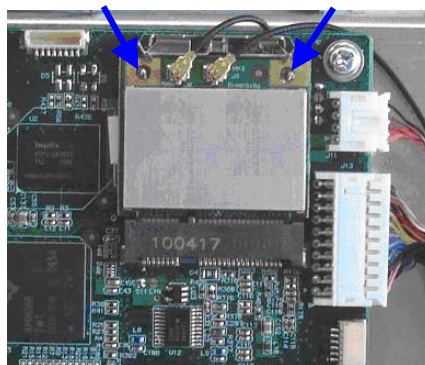

## 7.4.3 Removing SD Card (Optional)

Unscrew the M3x6 screw and press the SD card as indicated below to remove the SD card:

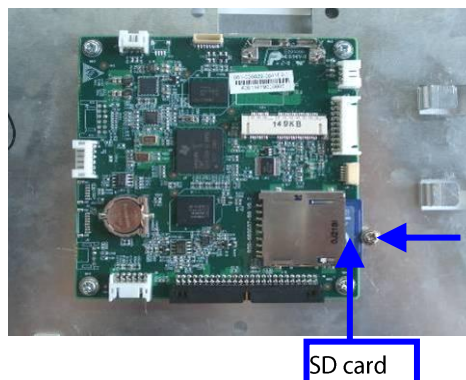

### 7.4.4 Removing the Main Board

Disconnect the alarm lamp cable, cable for display backlight, display cable, and the cable between the main control board and keypad respectively. Unscrew the four M3×8 screws and take out the main board, as shown below:

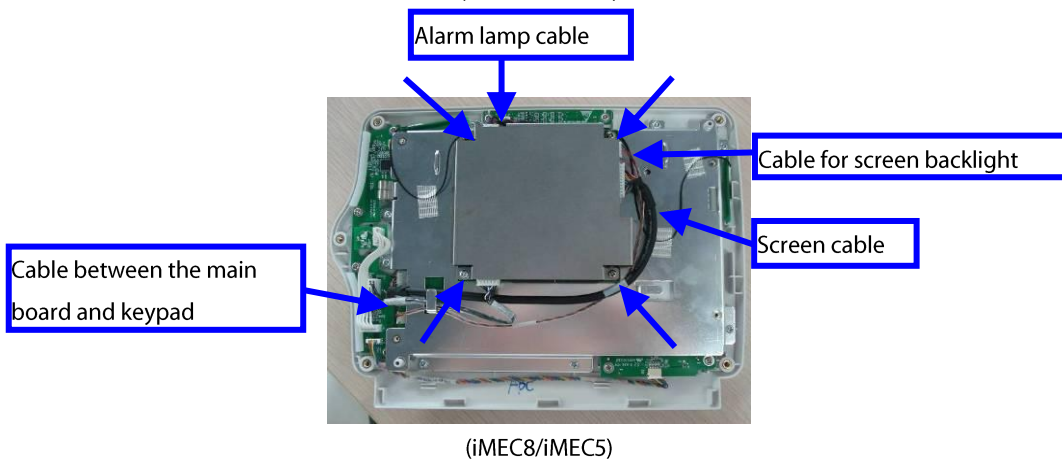
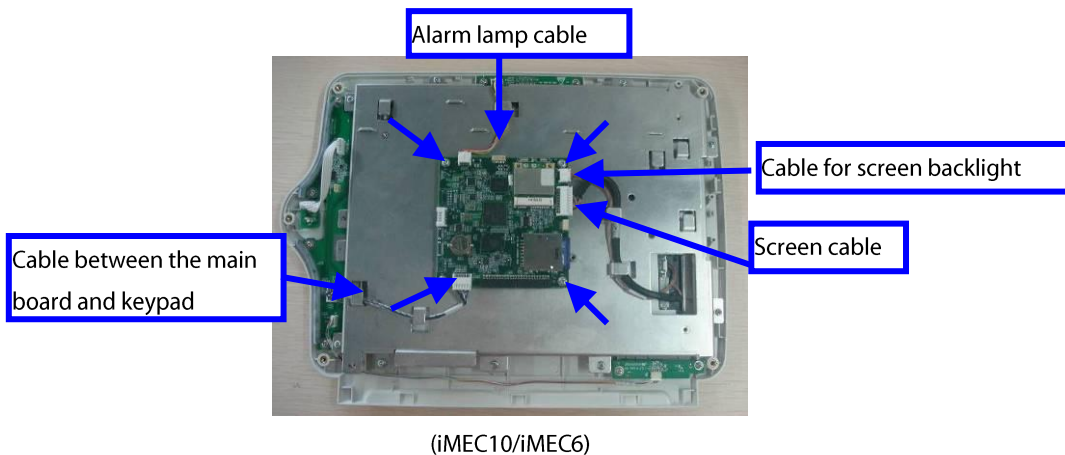
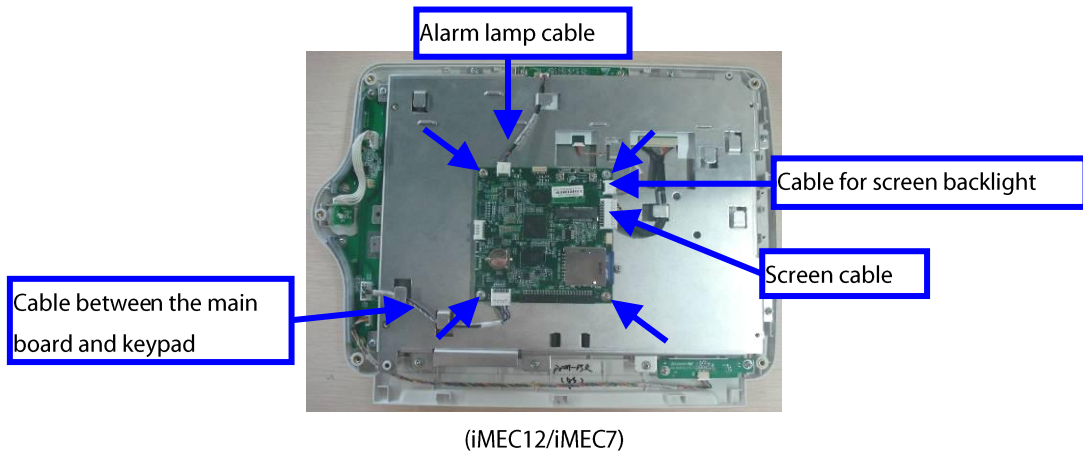

#### NOTE

- There is an additional shield cover on the front housing of iMEC8/iMEC5 patient monitors. But the disassembling method is the same with that of iMEC12/iMEC7/iMEC10/iMEC6 patient monitors.

### 7.4.5 Removing the Touchscreen (Optional)

iMEC12/iMEC7/iMEC10/iMEC6

Unscrew the ten M3x8 screws indicated below. Take out the touchscreen bracket and then the touchscreen.

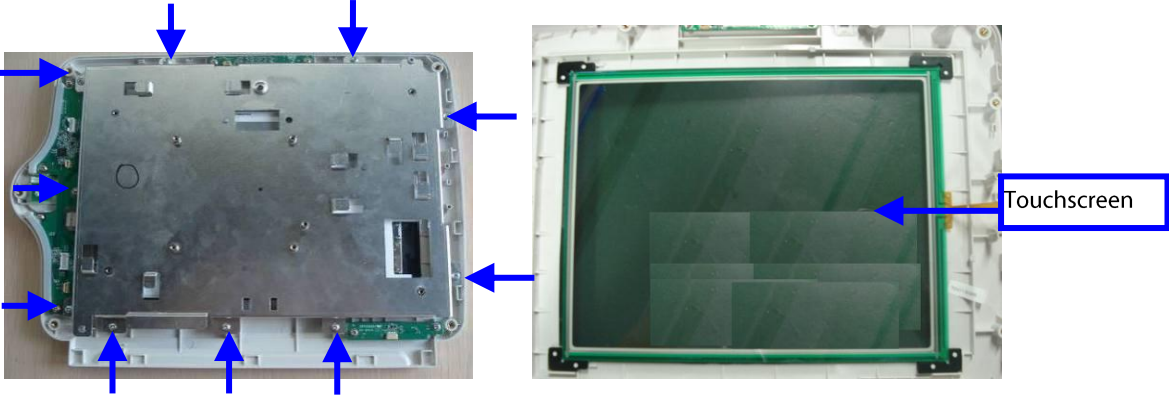

iMEC8/iMEC5

Unscrew the eight M3x8 screws indicated below. Take out the touchscreen bracket and then the touchscreen.

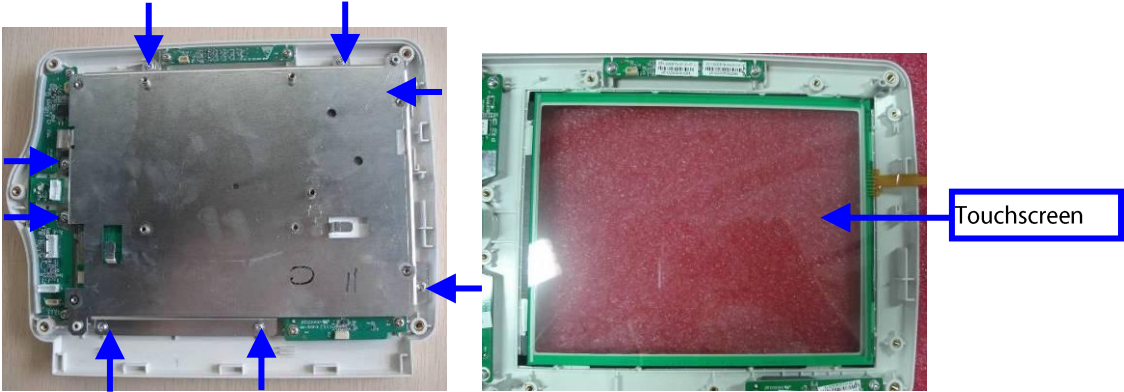

### 7.4.6 Disassembling the Screen

iMEC12/iMEC7/iMEC10/iMEC6

1. Unscrew the ten M3x8 screws indicated below. Then take out the screen bracket.

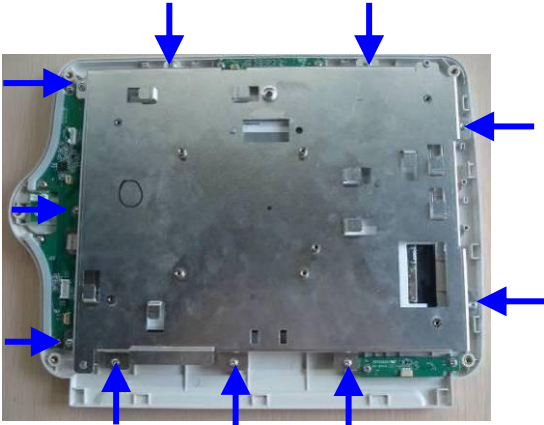

2. Unscrew the four M3×8 screws indicated below to remove the screen.



**iMEC8/iMEC5**

1. Unscrew the eight M3×8 screws indicated below. Then take out the screen bracket.

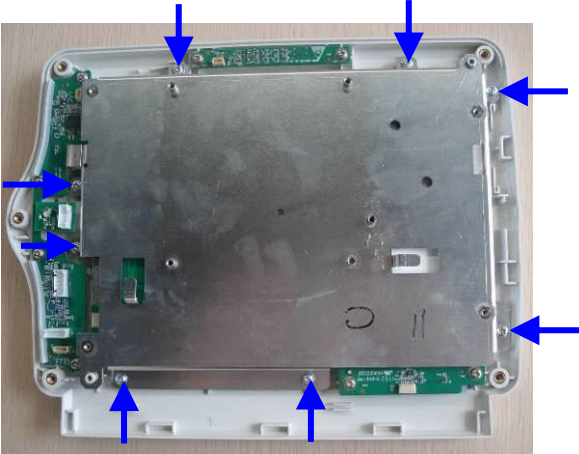

2. Unscrew the four M2.5×6 screws indicated below to remove the screen.



## 7.4.7 Removing the Keypad

iMEC12/iMEC7/iMEC10/iMEC6

Unplug the encoder cable and unscrew the five PT3×8 screws indicated below. Take out the keypad.

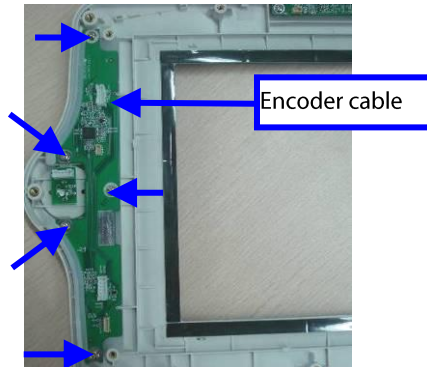

iMEC8/iMEC5

Unplug the encoder cable and unscrew the five PT3×8 screws indicated below. Take out the keypad.

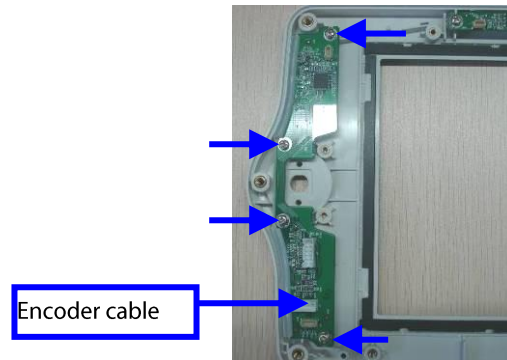

## 7.4.8 Removing the Encoder

Poke the encoder knob out from the slot and loose the nut with a sharp nose plier. Take out the encoder.



### 7.4.9 Removing the Alarm Lamp Board

Unscrew the two PT3×8 screws indicated below and take out the alarm lamp board.

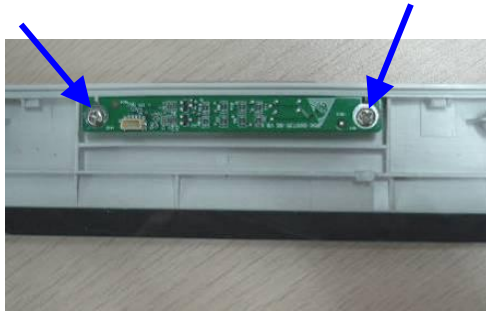

### 7.4.10 Removing the ON/OFF Key Board

Unscrew the two PT3×8 screws indicated below and take out the ON/OFF key board.

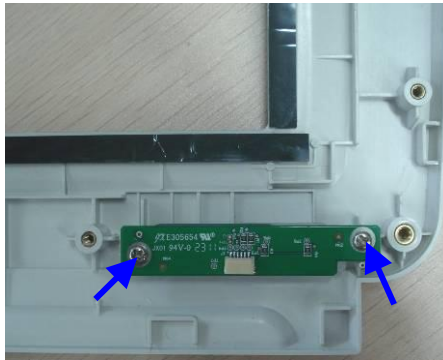

## 7.5 Disassembling the Battery Compartment Assembly

### 7.5.1 Removing the Power Board

Disconnect the cable for AC input receptacle. Remove the three M3×6 screws indicated below and remove the power board.

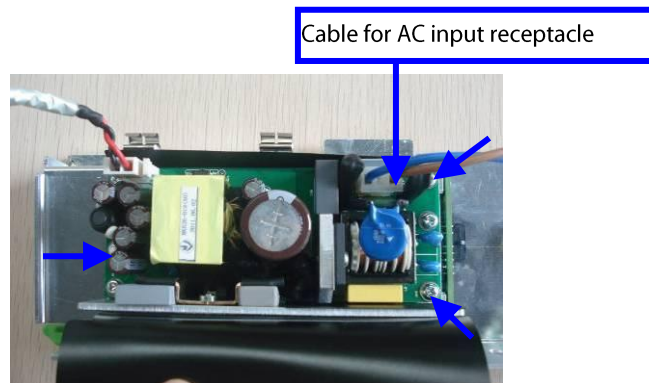

---

#### NOTE

- Follow the instructions and unscrew the correct screws.
-

## 7.5.2 Removing the Battery Interface Board Assembly

### iMEC12/iMEC7/iMEC10/iMEC6

Unscrew the two M3 nuts with a sharp nose plier and remove the battery interface board assembly.



### iMEC8/iMEC5

Unscrew the two M3x6 screws with a screwdriver and then take out the battery interface board.



## 7.6 Disassembling the Parameter Module Assembly

### NOTE

- Perform disassembly with exercise care to protect the boards on both sides of the module from damage.
- Be sure to reassemble the fast valve (red) and slow valve (blue) in correct sequence. The slow valve should be connected to the reducer-equipped end of the pipe.
- Operations relating to optional parts, like C.O. and CO<sub>2</sub>, may not apply to your equipment.

### 7.6.1 Removing the Mindray M02C CO<sub>2</sub> Module (Optional)

Unscrew the four M3x8 screws indicated below and then take out the Mindray M02C CO<sub>2</sub> module.

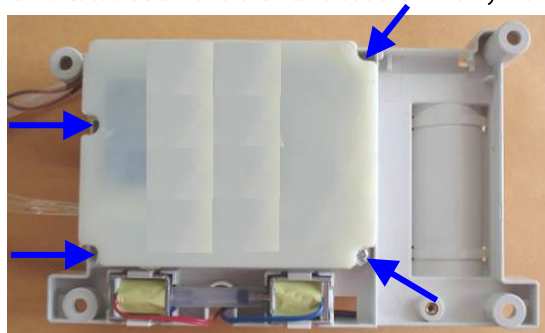

### 7.6.2 Removing the Mainstream CO<sub>2</sub> Module (Optional)

Unscrew the three M3×6 screws indicated below and then take out the mainstream CO<sub>2</sub> board.

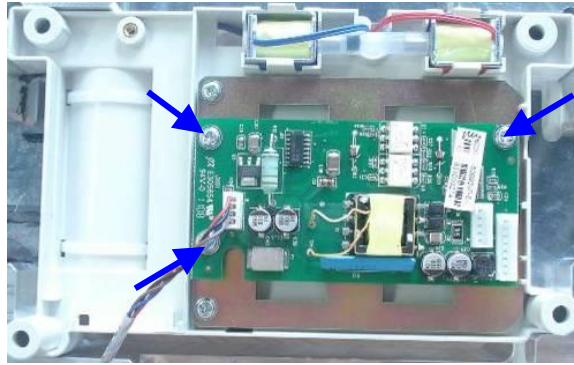

### 7.6.3 Removing the Microstream CO<sub>2</sub> module (Optional)

1. Unscrew the four M3×6 screws indicated below and then take out the microstream CO<sub>2</sub> module.

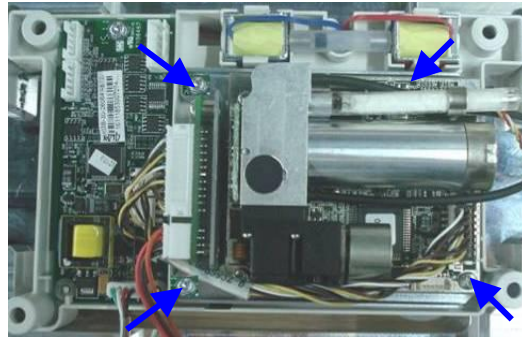

2. Then unscrew the three M3×6 screws and then take out the microstream converter, as shown below:



### 7.6.4 Removing the C.O. Module (Optional)

Unscrew the M3×6 screw indicated below and take out the C.O. module.

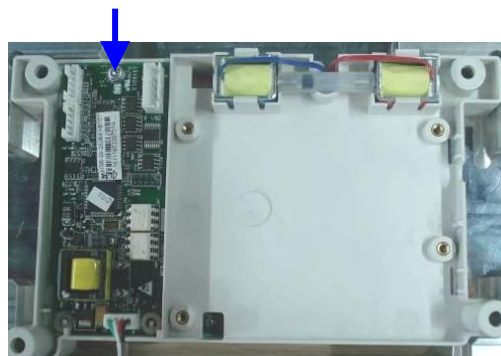



### 7.6.5 Removing the SpO<sub>2</sub> Board

Unscrew the two M3×6 screws indicated below and take out the SpO<sub>2</sub> board.



(Nellcor)



(Masimo)

### 7.6.6 Removing the Multi-parameter Module

Disconnect the pipe from the module. Then unscrew the four M3×6 screws and take out the multi-parameter module, as shown below:



### 7.6.7 Removing the Pump and Valve

1. Clip the cable holders indicated below with a clamp and take out the pump.

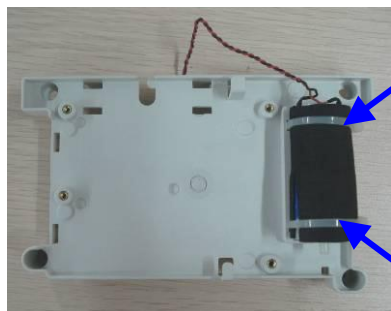

2. Push the four clamps indicated below aside and take out the valve.

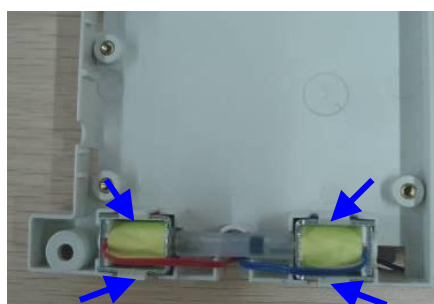

## 7.7 Removing the Parameter Connector Assembly

### 7.7.1 Removing the Mainstream CO<sub>2</sub> Signal Cable (Optional)

1. Push the four clamps aside as shown below and take out the mainstream CO<sub>2</sub> interface board.

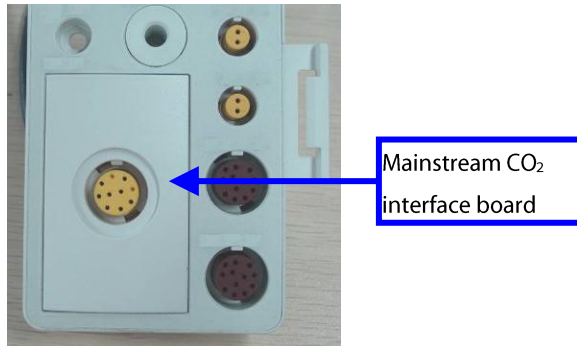

2. Screw the connector of the mainstream signal cable clockwise with a sharp nose plier. Pull the connector up to remove the mainstream signal cable.

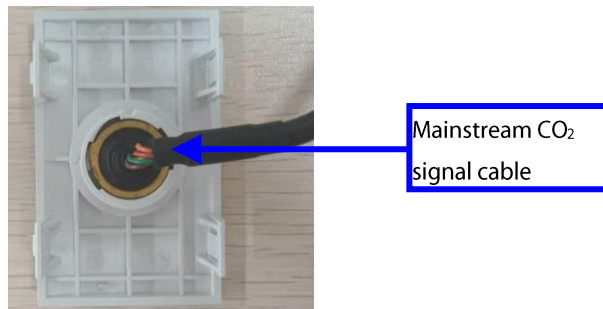

### 7.7.2 Removing the Microstream CO<sub>2</sub> Connector Assembly (Optional)

Push the four clamps aside as shown below and take out the microstream CO<sub>2</sub> interface assembly.

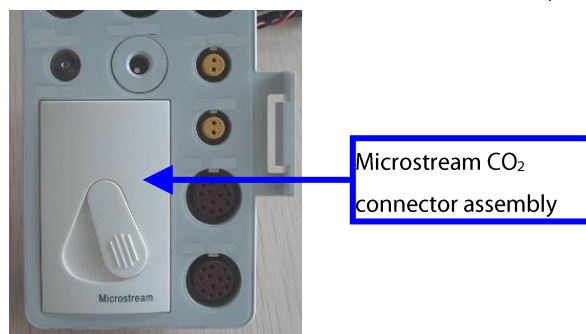

### 7.7.3 Removing the Watertrap Base Assembly (Optional)

1. Unscrew the two screws of the watertrap indicated below with a screwdriver and remove the watertrap base assembly.



Screw of the watertrap

2. Unscrew the four PT2x6 screws indicated below and take out the watertrap base bracket.



### 7.7.4 Removing the Cables from the Parameter Connector Assembly

To remove the cables, loose the connectors clockwise with a sharp nose plier; To reassemble the cables, screw the connectors counter-clockwise to the correct sockets as shown below:

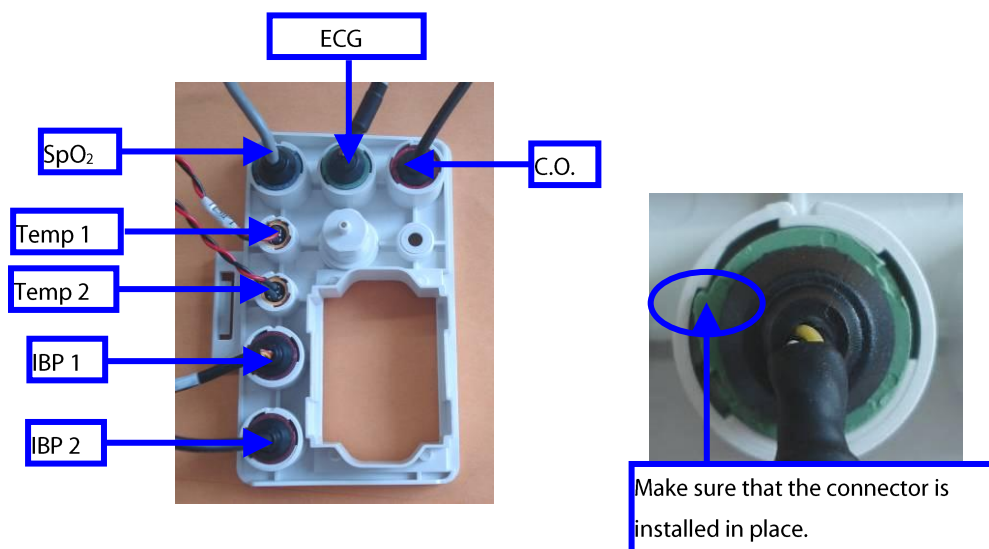

### 7.7.5 Removing the Recorder

1. Push the two clamps aside and take out the recorder drive board, as shown below:

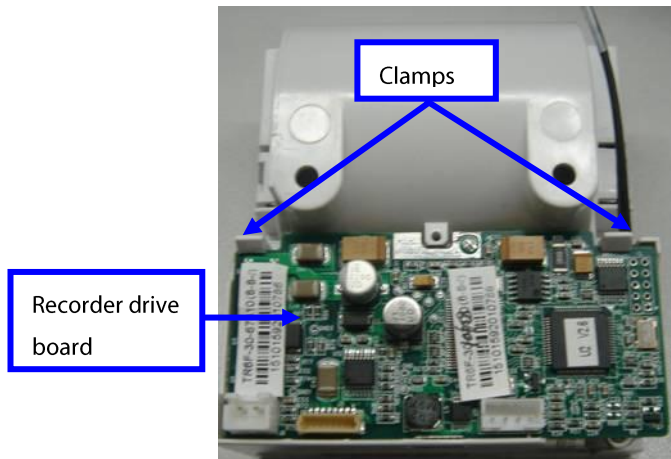

2. Unscrew the two PT2x6 screws and disconnect the cable between the recorder drive board and recorder keypad and the flexible cable, as shown below. Then remove the thermal print head and recorder drive board.

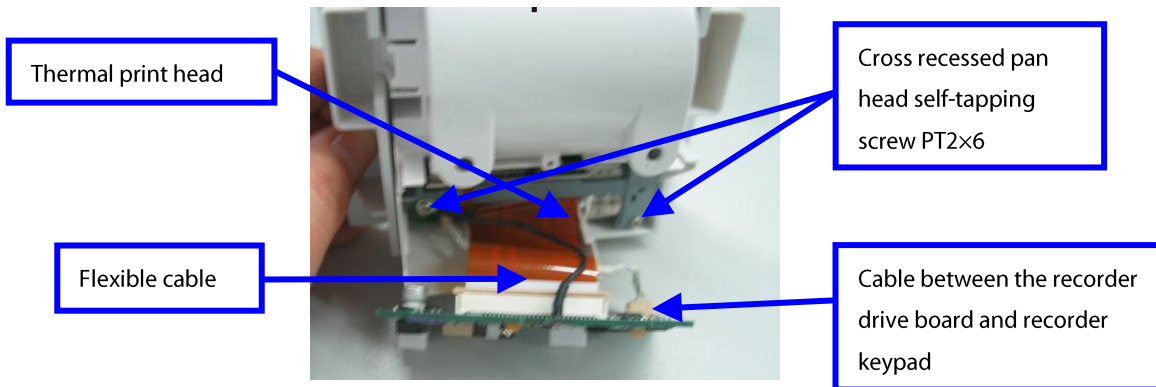

3. Unscrew the two PT2x6 screw indicated below and take out the keypad.

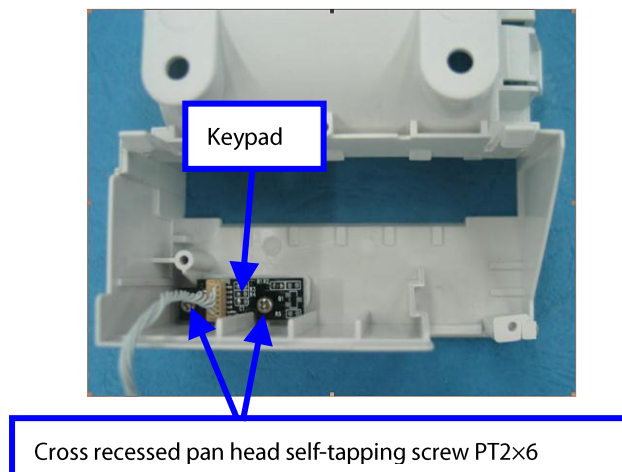

# 8 Parts

## 8.1 Introduction

This section contains the exploded views and parts lists of the main unit. It helps the engineer to identify the parts during disassembling the patient monitor and replacing the parts. This manual is based on the maximum configuration. Your equipment may not have same parts and the quantity of the screws or stacking sleeves etc. may be different with those included in the parts lists.

Hardware architecture of the main unit is shown below:

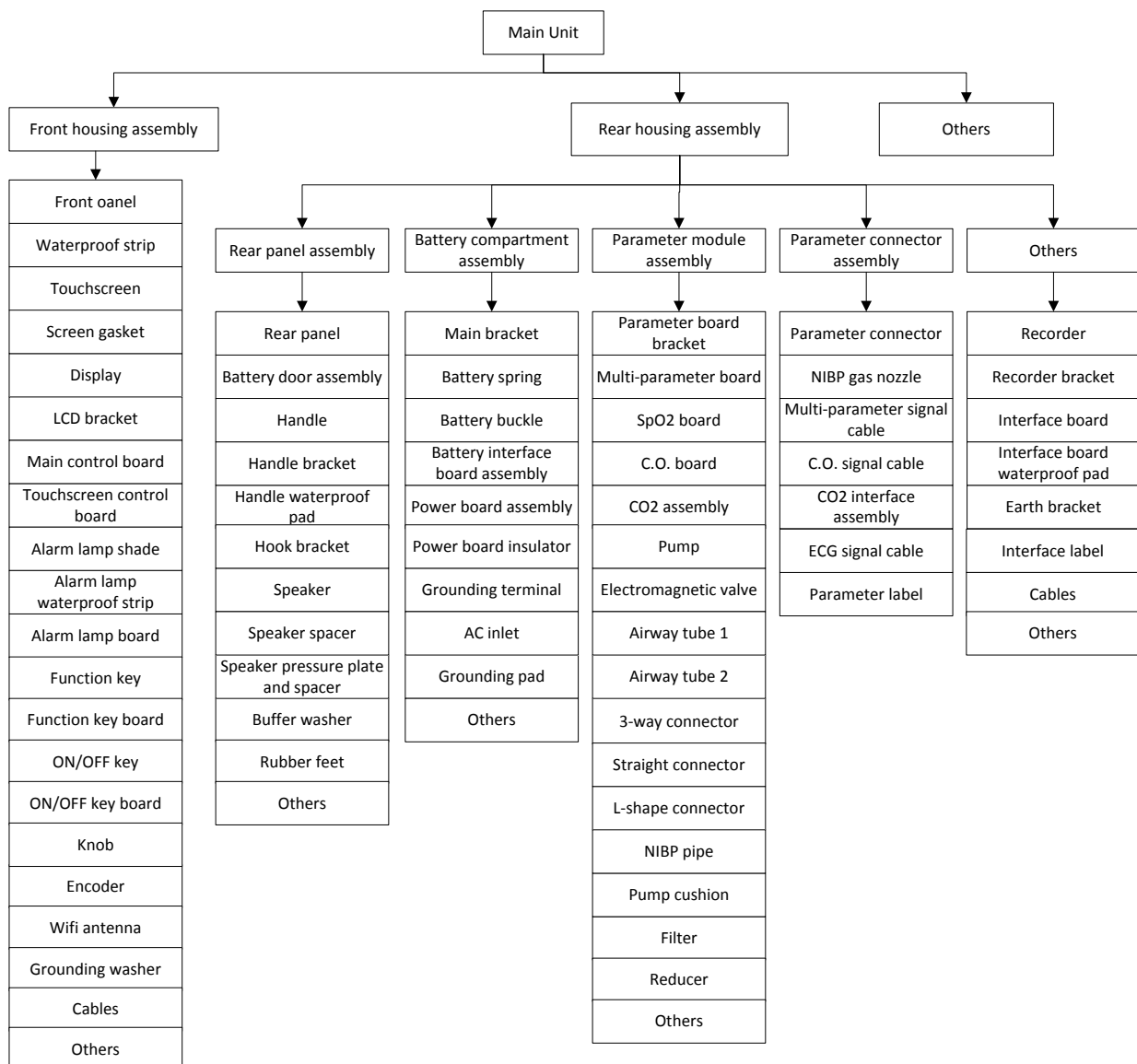

### NOTE

- The part number listed in the Parts List is only for checking the FRU part number which is also included in the Parts List. Please provide the FRU parts number if you want to purchase the spare parts.

## 8.2 iMEC8/iMEC5

### 8.2.1 Main unit

#### 8.2.1.1 Exploded View

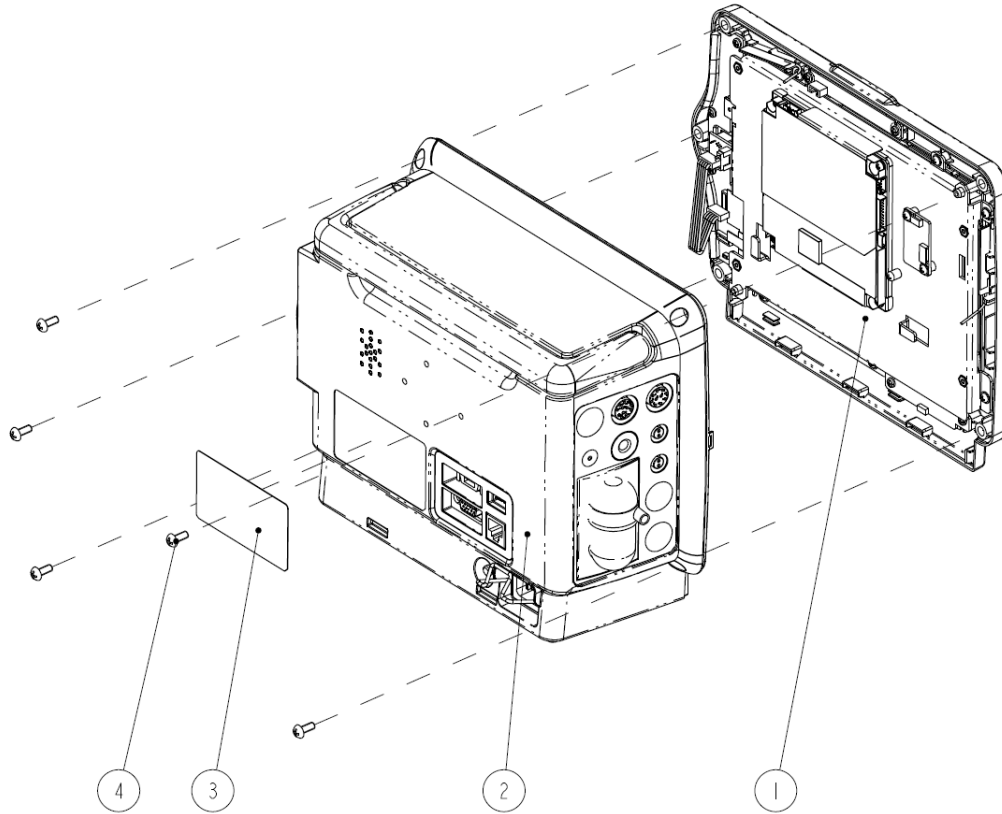

#### 8.2.1.2 Parts List

SN	PN	Description	FRU part number	Remarks
1.	/	Front panel subassembly (8 Inch/WiFi+ 1G SD card)	/	/
2.	/	Rear housing of the main unit (8 inch/Network/VGA/USB/Analog input & output)	/	/
3.	/	iMEC12 label (Chinese)	/	/
4.	/	Cross recessed pan head screw GB/T818-2000 M4×10	/	/

## 8.2.2 Front Housing Assembly (Nakescreen)

### 8.2.2.1 Exploded View

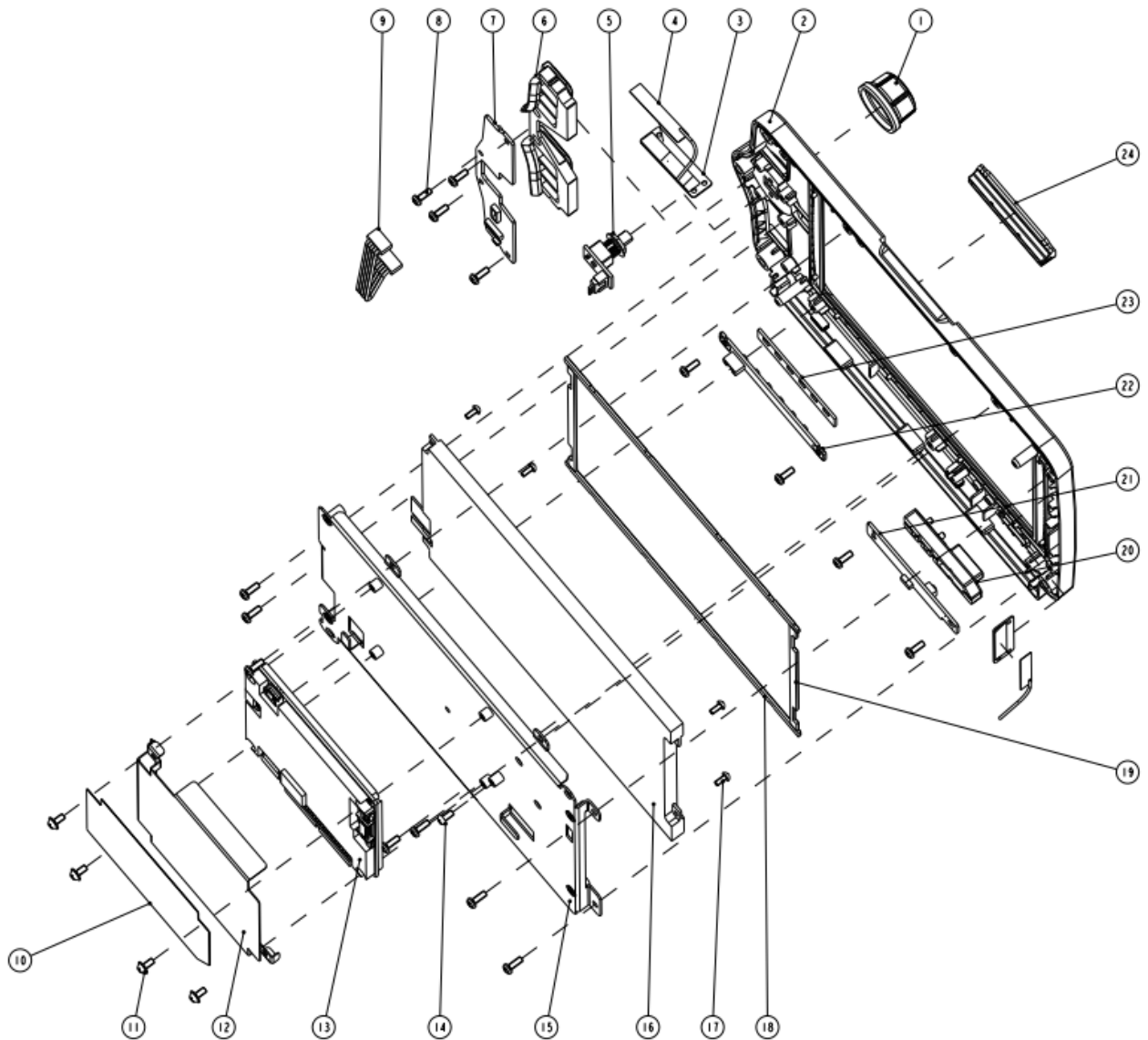

### 8.2.2.2 Parts List

SN	PN	Description	FRU part number	Remarks
1.	/	Knob	043-001790-00	/
2.	043-001965-01	Front housing (8 inch)	801-6302-00005-00	For monitors with machine screws
		Front housing (8 inch)	801-6302-00016-00	For monitors with tapping screws
3.	/	6301 Antenna attached PCB	115-010845-00	/
4.	/	Antenna, 2400-2500MHz 2.15dBI IPEX-II interface		
5.	/	Encoder	0010-30-43089	/
6.	/	Key (8 inch, Chinese)	049-000334-00	As configured

SN	PN	Description	FRU part number	Remarks
	/	Key (8 inch, English)	049-000350-00	
	/	Key (8 inch, Italian)	049-000380-00	
	/	Key (8 inch-Spanish)	049-000381-00	
	/	Key (8 inch, Portuguese)	049-000382-00	
	/	Key (8 inch, French)	049-000383-00	
	/	Key (8 inch, German)	049-000384-00	
7.	/	Keypad PCBA, 8.4 inch	051-000877-00	/
8.	/	Screw, self-tapping, PT3×8	/	/
9.	/	Encoder cable	9200-21-10460	/
10.	/	PCB shielding insulator	/	Optional
11.	/	Screw, Pan head with washer, Phillips M3×6	/	/
12.	/	PCB-shielding	/	Optional
13.	051-000829-00	6301 Main board PCBA (Full configuration )	801-6302-00001-00	As configured
	051-000964-00	6301 Main board PCBA (Standard configuration)	801-6302-00002-00	
14.	/	Screw, pan head Phillips, M3×6	/	/
15.	/	Display bracket (8 inch nakescreen)	/	/
16.	/	Truly LED display, 8.4"	021-000078-00	As configured/Not mutually compatible nor exchangeable
	/	AU LED, TFT, 8.4"	021-000060-00	
17.	/	Screw, pan head Phillips, M2.5×6	/	/
18.	/	Long gasket, 8", nakescreen	/	/
19.	/	Short gasket, 8", nakescreen	/	/
20.	/	Power button	6802-20-66691	/
21.	/	6301 On/Off key board PCBA	051-000880-00	/
22.	051-000879-01	6301 alarm board PCBA	801-6301-00005-00	/
23.	/	Alarm lamp gasket	/	/
24.	/	Alarm lamp	/	/



## 8.2.3 Front Housing Assembly (Touchscreen)

### 8.2.3.1 Exploded View

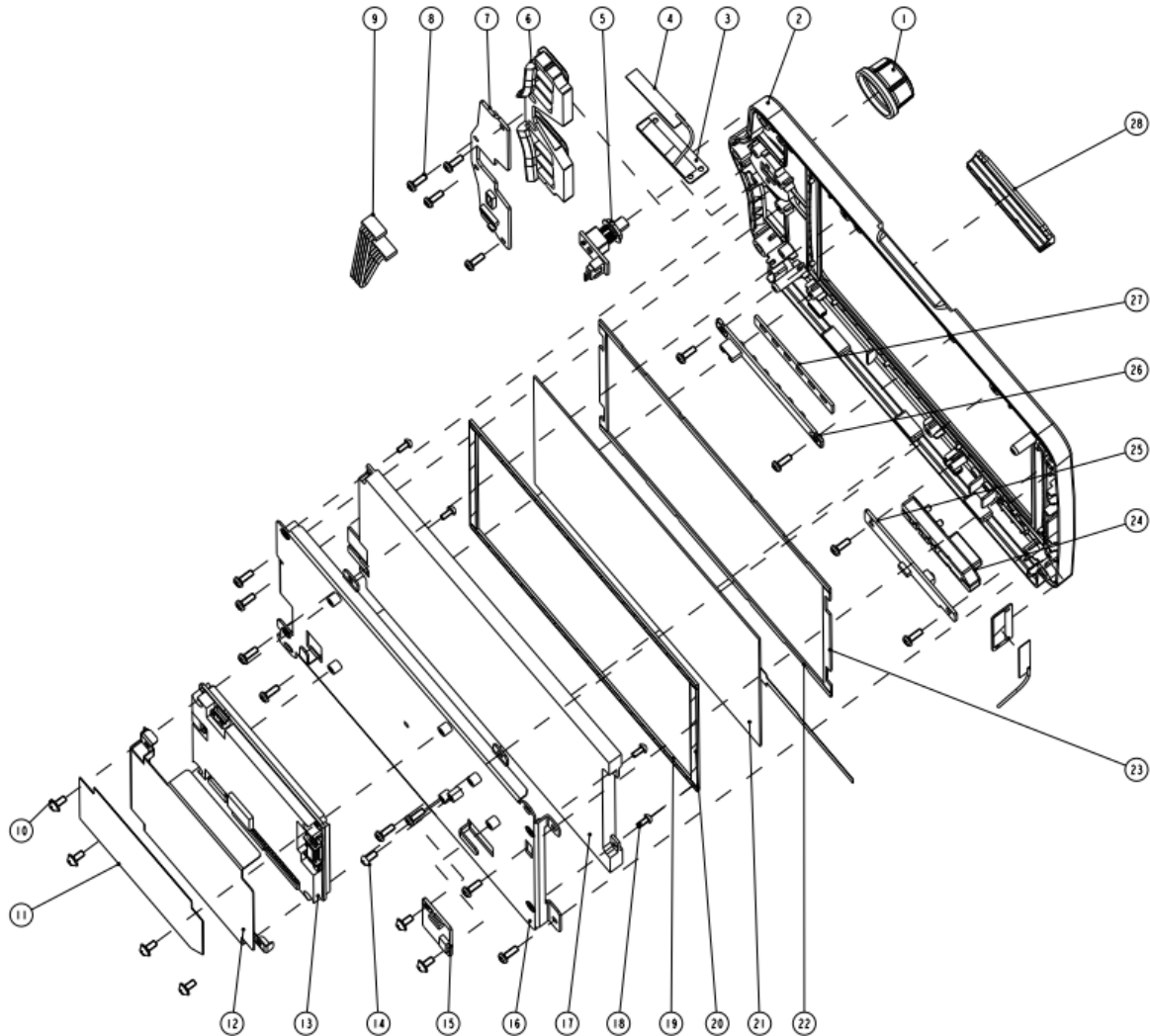

### 8.2.3.2 Parts List

SN	PN	Description	FRU part number	Remarks
1.	/	Knob	043-001790-00	/
2.	043-001965-01	Front housing (8 inch)	801-6302-00006-00	For monitors with machine screws
		Front housing (8 inch)	801-6302-00017-00	For monitors with tapping screws
3.	/	6301 Antenna attached PCB	115-010845-00	/
4.	/	Antenna		
5.	/	Knob	0010-30-43089	/
6.	/	Key (8 inch, Chinese)	049-000334-00	/
	/	Key (8 inch, English)	049-000350-00	
	/	Key (8 inch, Italian)	049-000380-00	
	/	Key (8 inch-Spanish)	049-000381-00	

SN	PN	Description	FRU part number	Remarks
	/	Key (8 inch, Portuguese)	049-000382-00	
	/	Key (8 inch, French)	049-000383-00	
	/	Key (8 inch, German)	049-000384-00	
7.	/	6301 keypad PCBA 8.4 inch	051-000877-00	/
8.	/	Screw, self-tapping, PT3×8	/	/
9.	/	Encoder cable	9200-21-10460	/
10.	/	Screw, Pan head with washer, Phillips M3×6	/	/
11.	/	PCB shielding insulator	/	Optional
12.	/	PCB-shielding	/	Optional
13.	051-000829-00	Main board PCBA	801-6302-00001-00	/
14.	/	Screw, pan head Phillips, M3×6	/	/
15.	/	Touchscreen control board PCBA	051-000881-00	/
16.	/	Screen bracket (8 inch touchscreen)	/	/
17.	021-000078-00	Truly LED display, 8.4"	801-6302-00013-00	As configured/Not mutually compatible nor exchangeable
	021-000060-00	AU LED, TFT, 8.4"	801-6302-00003-00	
18.	/	Screw, Phillips, M2.5×6	/	/
19.	/	Long pressing strip for 8 inch display bracket	/	/
20.	/	Short pressing strip for 8 inch display bracket	/	/
21.	/	Touchscreen, resistive-type, 8.4" 4-line	021-000058-00	/
22.	/	Long gasket, 8", touchscreen	/	/
23.	/	Short gasket, 8", touchscreen	/	/
24.	/	Power button	6802-20-66691-51	/
25.	/	6301 On/Off key board PCBA	051-000880-00	/
26.	051-000879-01	6301 alarm board PCBA	801-6301-00005-00	/
27.	/	Alarm lamp gasket	/	/
28.	/	Alarm lamp	/	/

## 8.2.4 Rear Housing (Network/VGA/USB/Analog Input & Output)

### 8.2.4.1 Exploded View

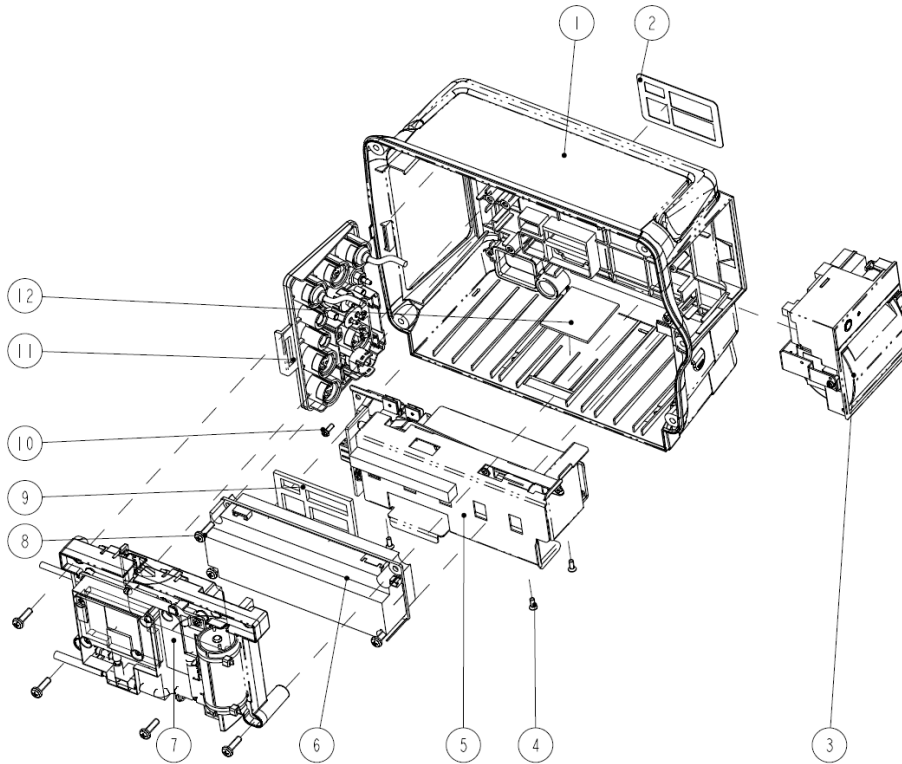

### 8.2.4.2 Parts List

SN	PN	Description	FRU part number	Remarks
1.	/	Rear Housing Assembly (8 Inch)	115-010391-00	Use with tapping screws
2.	/	IO label (all)	/	/
3.	TR6F-30-67306	TR6F recorder	801-6800-00080-00	/
	/	Recorder door	9211-20-87402	/
4.	/	Screw, M3×8,Cross recessed countersunk head, GB/T819.1-2000	/	/
5.	/	Battery Compartment Assembly (8 inch)	115-010390-00	/
6.	051-000850-00	PCBA,6301 Power management/interface board	801-6301-00001-00	As configured
	051-000965-00	6301 Power management and interface board PCBA (with standard configuration)	801-6301-00002-00	
7.	/	Parameter module assembly (ECG+Temp+NIBP+Mindray SpO <sub>2</sub> )	/	As configured
	/	Parameter module assembly (ECG+Temp+NIBP+Nellcor SpO <sub>2</sub> )	/	
	/	Parameter module assembly (ECG+Temp+NIBP+Masimo SpO <sub>2</sub> )	/	
	/	Parameter module assembly (ECG+Temp+NIBP+Mindray SpO <sub>2</sub> +IBP)	/	

SN	PN	Description	FRU part number	Remarks
	/	Parameter module assembly (ECG+Temp+NIBP+Nellcor SpO <sub>2</sub> +IBP)	/	
	/	Parameter module assembly (ECG+Temp+NIBP+Mindray SpO <sub>2</sub> , analog output)	/	
8.	/	Cross recessed pan head self-tapping screw PT 4×14	/	/
9.	/	Interface board gasket	/	/
10.	/	Cross recessed pan head self-tapping screw PT3×8	/	/
11.	/	Parameter connector panel assembly (ECG+Temp+NIBP+Mindray SpO <sub>2</sub> )	115-010355-00	As configured
	/	Parameter connector panel assembly (ECG+Temp+NIBP+Nellcor SpO <sub>2</sub> )	115-010356-00	
	/	Parameter connector panel assembly (ECG+Temp+NIBP+Masimo SpO <sub>2</sub> )	115-010357-00	
	/	Parameter connector panel assembly (ECG+Temp+NIBP+Mindray SpO <sub>2</sub> +IBP)	115-010358-00	
	/	Parameter connector panel assembly (ECG+Temp+NIBP+Nellcor SpO <sub>2</sub> +IBP)	115-010359-00	
	/	Parameter connector panel assembly (ECG+Temp+NIBP+Masimo SpO <sub>2</sub> +IBP)	115-010360-00	
12.	/	Thermal conductive gel for AC board	/	/

## 8.2.5 Rear Housing Assembly

### 8.2.5.1 Exploded View

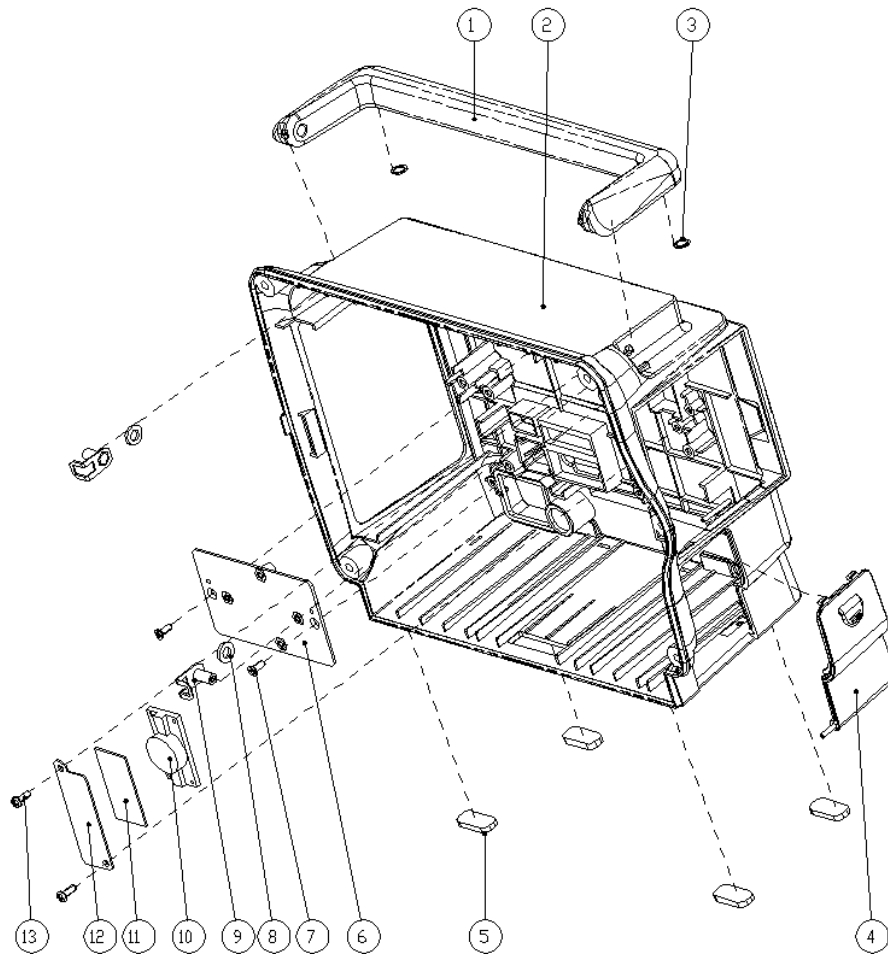

### 8.2.5.2 Parts List

SN	PN	Description	FRU part number	Remarks
1.	043-001793-00	Handle (8 inch)	801-6302-00007-00	/
2.	043-001966-01	Rear housing (8 inch)	115-010391-00	/
3.	/	Buffer cushion, Bumpon SJ5302	/	/
4.	/	Battery door subassembly (8 inch)	801-6302-00004-00	/
5.	/	Rubber feet	/	/
6.	/	Hook bracket	/	/
7.	/	Cross recessed pan head self-tapping screw PT3x8	/	/
8.	/	Handle waterproof pad	/	/
9.	/	Handle bracket	/	/
10.	/	Speaker, 2W, 4ohm, 60mm	020-000015-00	/
11.	/	Gasket, speaker pressure plate and spacer	/	/
12.	/	Gasket, speaker spacer	/	/
13.	/	Cross recessed pan head self-tapping screw PT3x8	/	/

## 8.2.6 Battery Compartment Assembly

### 8.2.6.1 Exploded View

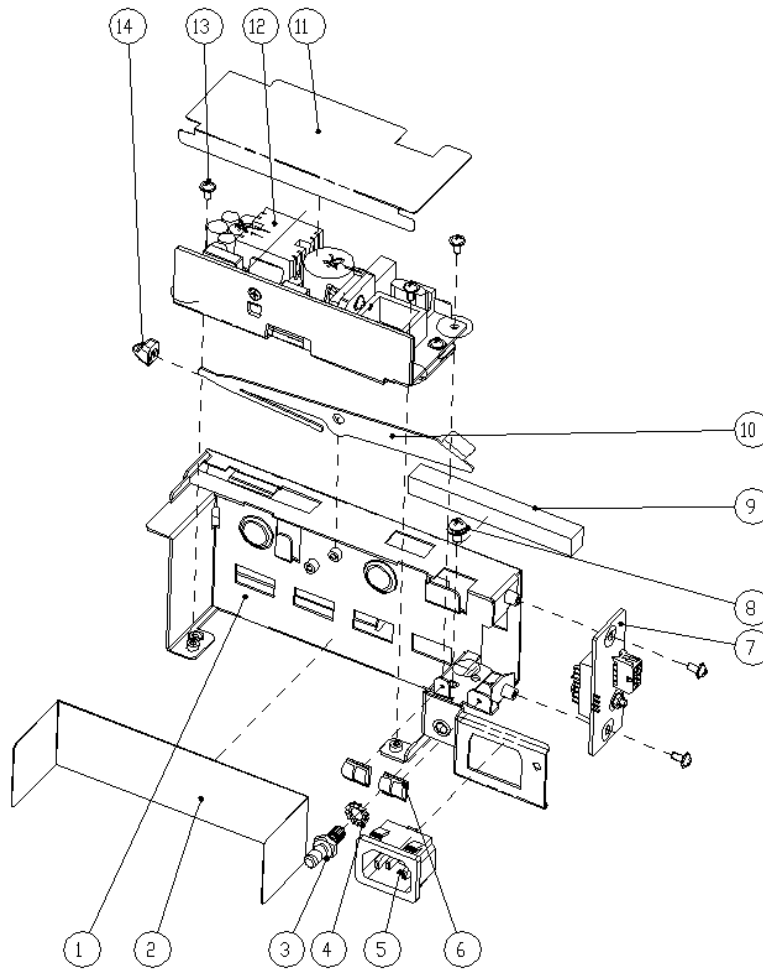

### 8.2.6.2 Parts List

SN	PN	Description	FRU part number	Remarks
1.	/	Main bracket (8 inch)	/	/
2.	/	Bracket insulator	/	/
3.	/	Grounding terminal	/	/
4.	/	Serrated lock washers external teeth 6	/	/
5.	/	Cable for AC input receptacle	009-002107-00	/
6.	/	Battery interface board	051-000891-00	/
7.	/	M4x8 combined screw	/	/
8.	/	Screen sponge, D-shape, 12.7x9.5mm	/	/
9.	/	Spring, EMI	/	/
10.	/	Battery Spring (8 inch)	/	/
11.	/	Power board insulator	/	/
12.	/	6301 AC/DC power PCBA	051-001064-00	/
13.	/	Screw, Phillips M3x6, with washer	/	/
14.	/	Knob, battery latch	/	/

## 8.2.7 Parameter module assembly

### 8.2.7.1 Exploded View

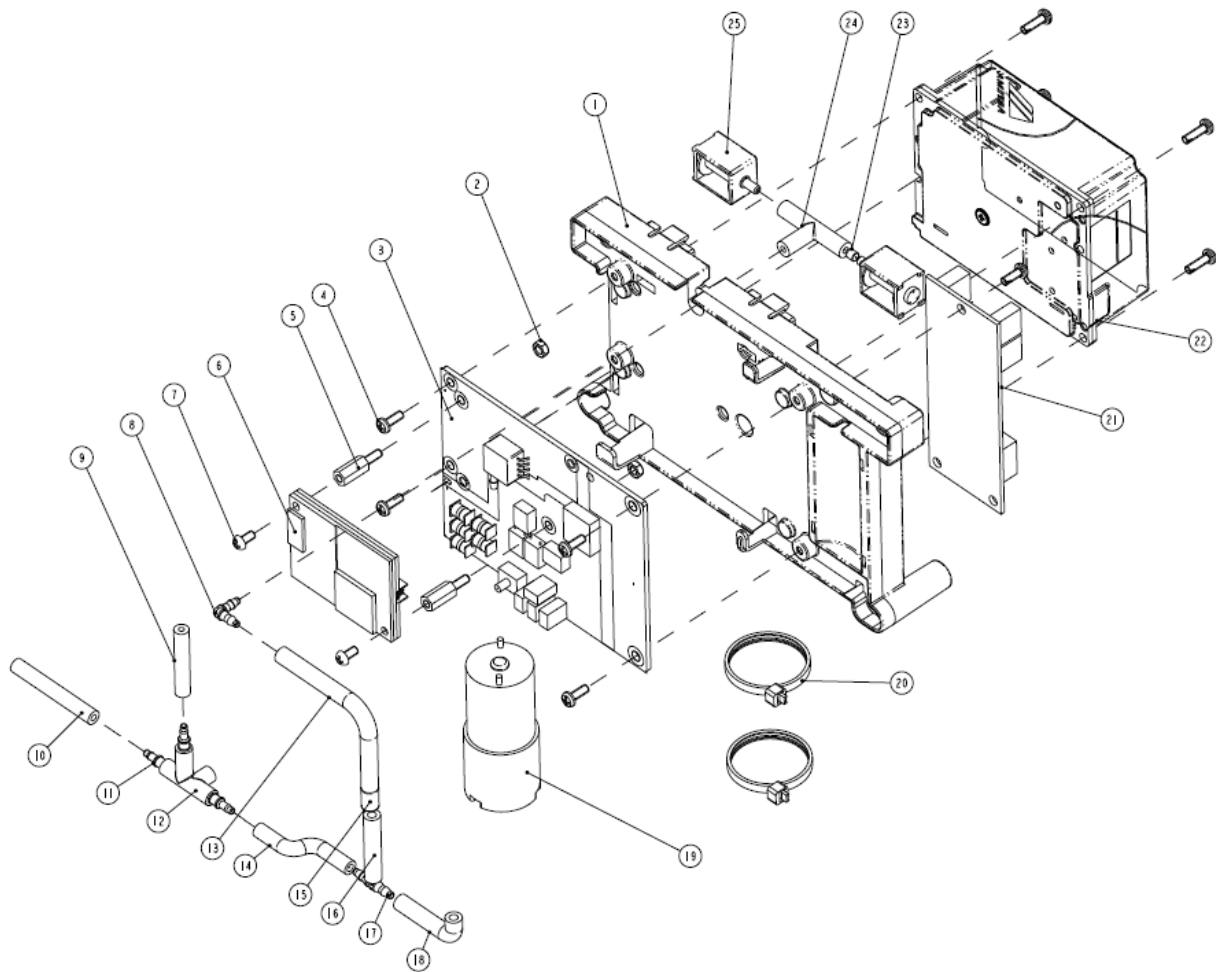

### 8.2.7.2 Parts List

SN	PN	Description	FRU part number	Remarks
1.	/	Parameter PCBA bracket	/	/
2.	/	Hexagon plastic nut, M3×0.5P, PC	/	/
3.	/	MEC Multi-parameter board PCBA (complete)	051-000950-00	As configured (international)
	/	MEC Multi-parameter board PCBA (standard)	051-000949-00	
	051-000950-00	MEC Multi-parameter PCBA (China)	801-6301-00006-00	As configured (China)
	051-000949-00	MEC Multi-parameter PCBA (China)	801-6301-00007-00	
4.	/	Screw, self-tapping, PT3×8	/	/
5.	/	Hexagonal plate isolator	/	/
6.	/	Nellcor SpO <sub>2</sub> board	0671-00-0102-01	/
	/	Masimo MS-2013 SpO <sub>2</sub> board (For Shenzhen Mindray only)	040-001149-00	/
	/	9008 V2.0 SpO <sub>2</sub> board PCBA	051-000943-00	/
7.	/	Screw, pan head Phillips, M3×6	/	/
8.	/	Connector, Elbow, 200Barb, 3/32"ID, White Nylon	/	/
9.	/	NIBP pipe 2	/	/

SN	PN	Description	FRU part number	Remarks
10.	/	NIBP pipe 7	/	/
11.	/	Plastic connector	/	/
12.	/	Airway tube 2	/	/
13.	/	NIBP pipe 5	/	/
14.	/	NIBP pipe 3	/	/
15.	/	Filter, inline filter 43um 1/8" I.D.Tubing	/	/
16.	/	NIBP pipe 6	/	/
17.	/	Connector, Tee, 200Barb, 3/32"ID, White Nylon	/	/
18.	/	NIBP pipe 4	/	/
19.	/	Pump, 12V DC, with 120 mm wire and connector	082-000862-00	/
20.	/	Cable holder, CHS-4x150mm, Nylon	/	/
21.	/	C.O./IBP (M03B) module	M03B-30-26064	Optional
22.	/	Mindray sidestream CO <sub>2</sub> module kit	/	As configured
	/	Capnostat Mainstream CO <sub>2</sub> module kit	/	
	/	Ordion Microstream CO <sub>2</sub> module kit	/	
23.	/	630F reducer	/	/
24.	/	Airway tube	/	/
25.	/	Gas valve, fast, 12VDC 300mmHg	082-000861-00	/



### 8.2.8 Parameter connector panel assembly

#### 8.2.8.1 Exploded View

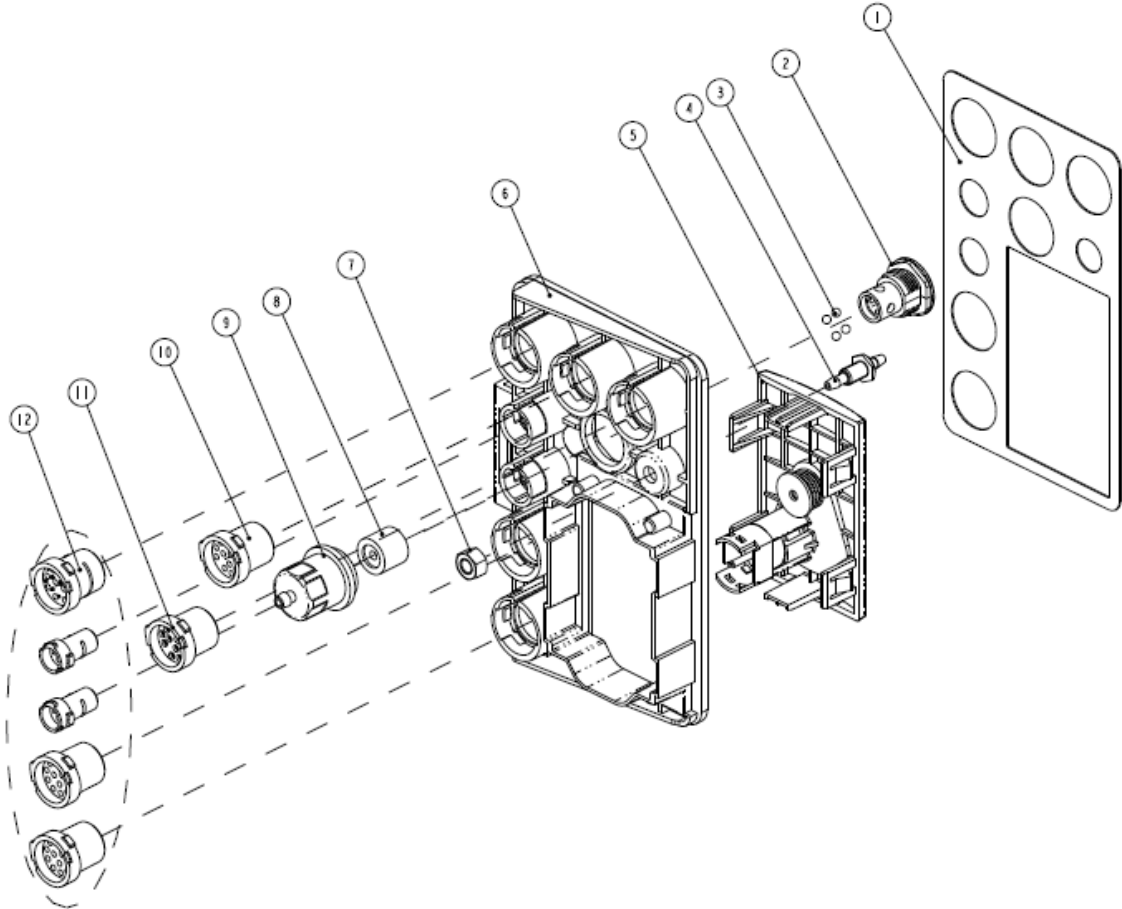

#### 8.2.8.2 Parts List

SN	PN	Description	FRU part number	Remarks
1.	/	Parameter label (standard)	047-005546-00	As configured
	/	Label (standard+IBP+C.O.+sidestream/microstream CO <sub>2</sub> )	047-005695-00	
	/	Label (standard+IBP)	047-005756-00	
	/	Label (standard+C.O.)	047-005757-00	
	/	Label (standard+C.O.+sidestream/microstream CO <sub>2</sub> )	047-005758-00	
	/	Label (standard+mainstream CO <sub>2</sub> )	047-005759-00	
	/	Label (standard+C.O.+sidestream/microstream CO <sub>2</sub> )	047-005760-00	
	/	Label (standard+C.O.+mainstream CO <sub>2</sub> )	047-005761-00	
	/	Label (standard+IBP+C.O.)	047-005762-00	
	/	Label (standard+IBP+sidestream/microstream CO <sub>2</sub> )	047-005763-00	
	/	Label (standard+IBP+mainstream CO <sub>2</sub> )	047-005764-00	
	/	Label (standard+IBP+C.O.+mainstream CO <sub>2</sub> )	047-005765-00	
2.	/	NIBP pedestal (hexagon)	/	/

SN	PN	Description	FRU part number	Remarks
3.	/	Steal ball, φ2.5	/	/
4.	/	Gas outlet	/	/
5.	/	Microstream CO <sub>2</sub> connector assembly	9201-30-35923	As configured
	/	Watertrap pedestal assembly (M02C)	115-010540-00	
	/	Mainstream CO <sub>2</sub> interface board	/	
6.	/	Parameter panel	/	/
7.	/	Nut, Stainless Steel M5 GB6170	/	/
8.	/	Silicon jacket	/	/
9.	/	NIBP external pedestal	/	/
10.	/	ECG signal cable	009-001678-00	/
11.	/	C.O. signal cable	009-001993-00	Optional
12.	/	Multi-parameter signal cable, with IBP, Mindray	009-001679-00	As configured
	/	Multi-parameter signal cable (Nellcor SpO <sub>2</sub> +Temp+IBP)	009-001680-00	
	/	Multi-parameter signal cable (Masimo SpO <sub>2</sub> +Temp+IBP)	009-001681-00	
	/	Multi-parameter signal cable (Mindray SpO <sub>2</sub> +Temp)	009-002123-00	
	/	Multi-parameter signal cable (Nellcor SpO <sub>2</sub> +Temp)	009-002124-00	
	/	Multi-parameter signal cable (Masimo SpO <sub>2</sub> +Temp)	009-002125-00	

## 8.2.9 Mindray Sidestream CO<sub>2</sub> Module Kit

### 8.2.9.1 Exploded View

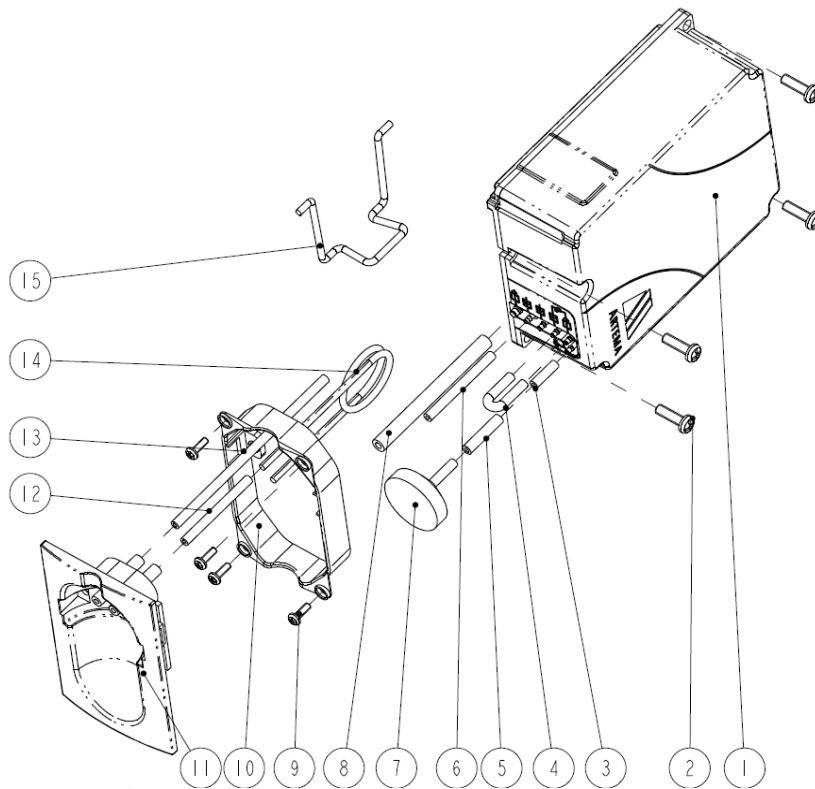

### 8.2.9.2 Parts List

SN	PN	Description	FRU part number	Remarks
1.	/	CO <sub>2</sub> module unit (M02C)	115-010077-00	/
2.	/	Cross recessed pan head self-tapping screw PT3×10, stainless steel	/	/
3.	/	AG airway sampling line (T=10)	/	/
4.	/	AG airway sampling line (T=50, U-type)	/	/
5.	/	Silicon tube (T=15)	/	/
6.	/	AG airway sampling line (T=50)	/	/
7.	/	Air filter GB8368-98	/	/
8.	/	AG airway sampling line (T=90)	/	/
9.	/	Cross recessed pan head self-tapping screw PT2.0×6	/	/
10.	/	AG watertrap bracket	/	/
11.	/	AG watertrap receptacle	115-010540-00	/
12.	/	AG airway sampling line (T=30)	/	/
13.	/	AG airway sampling line (T=110)	/	/
14.	/	Moisture exchanger (Nafion Tube for Mindray CO <sub>2</sub> )	/	/
15.	/	AC Inlet Hook	9211-20-87369	/

### 8.2.10 Ordion Microstream CO<sub>2</sub> Module Kit

#### 8.2.10.1 Exploded View

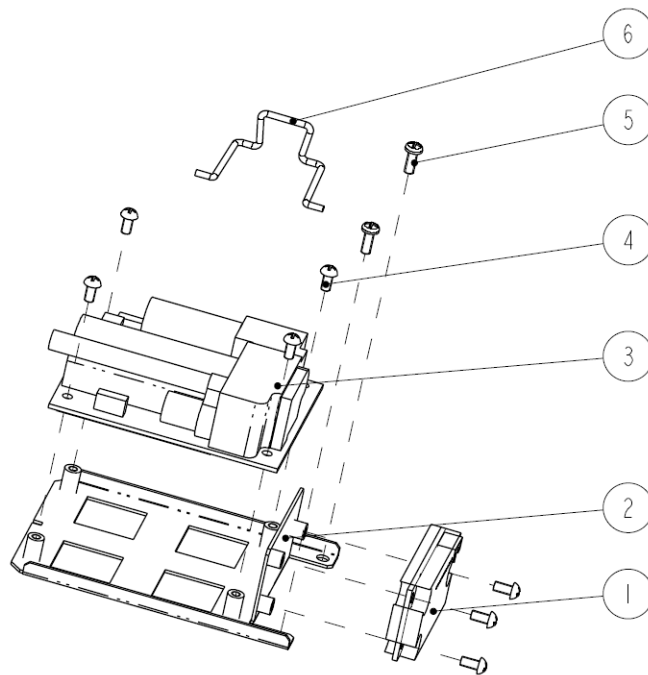

### 8.2.10.2 Parts List

SN	PN	Description	FRU part number	Remarks
1.	/	6301 Microstream converter PCBA	051-000892-00	/
2.	/	Microstream CO <sub>2</sub> bracket	/	/
3.	/	Microstream CO <sub>2</sub> module, MiniMediCO2-9	0010-10-42559	/
4.	/	Cross recessed pan head screw GB/T818-2000 M3×6	/	/
5.	/	Cross recessed pan head self-tapping screw PT3×8	/	/
6.	/	AC Inlet Hook	9211-20-87369	/

### 8.2.11 Capnostat Mainstream CO<sub>2</sub> module kit

#### 8.2.11.1 Exploded View

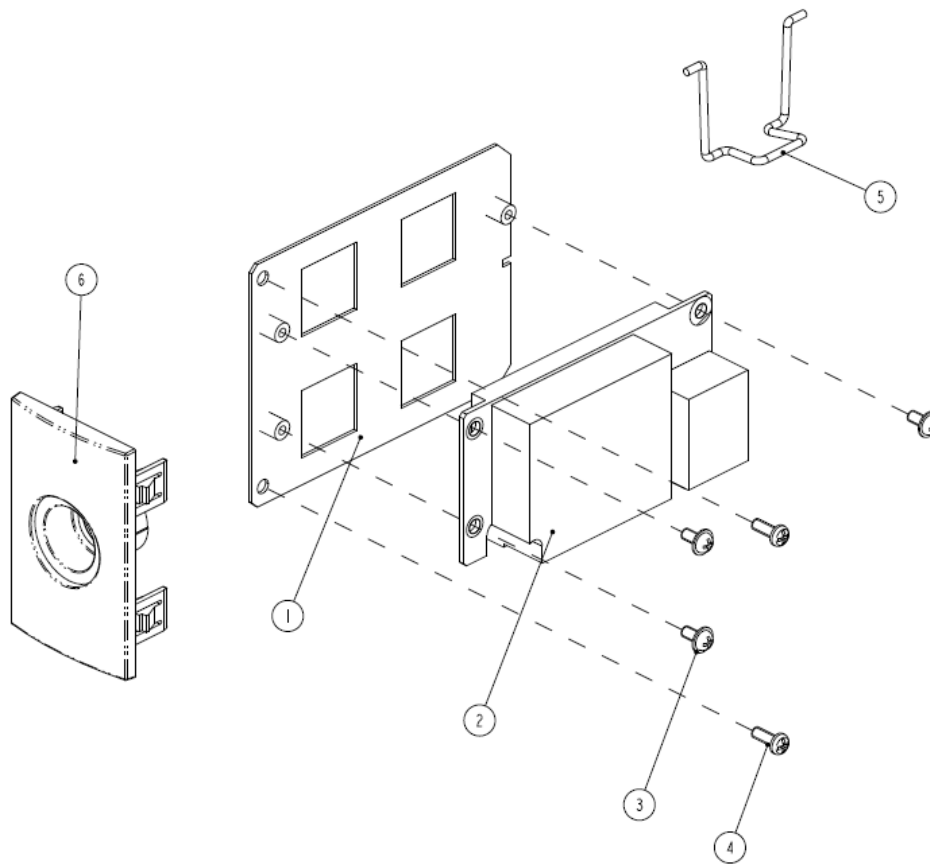

#### 8.2.11.2 Parts List

SN	PN	Description	FRU part number	Remarks
1.	/	Mainstream CO <sub>2</sub> bracket	/	/
2.	/	Power isolation board PCBA of 6301 mainstream CO <sub>2</sub>	051-001038-00	/
3.	/	Screw, Pan head with washer, Phillips M3×6	/	/
4.	/	Screw, self-tapping, PT3×8	/	/
5.	/	AC Inlet Hook	9211-20-87369	/
6.	/	Mainstream CO <sub>2</sub> interface board	/	/

**8.2.12 TR6F Recorder Kit**

**8.2.12.1 Exploded View**

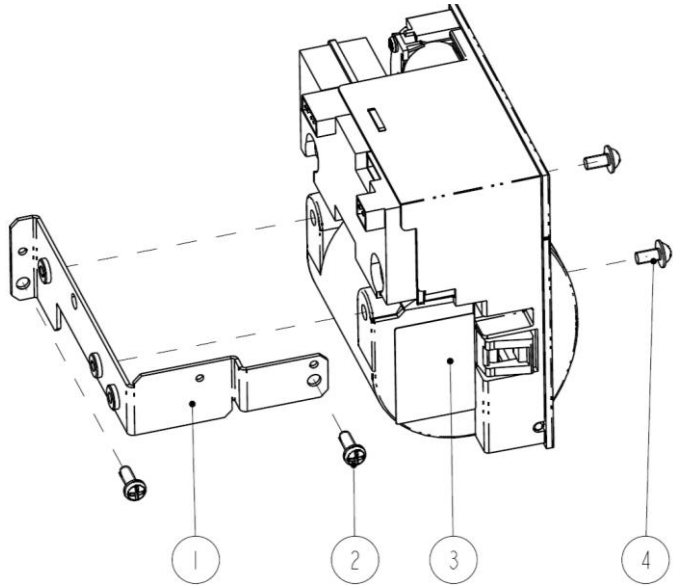

**8.2.12.2 Parts List**

SN	PN	Description	FRU part number	Remarks
1.	/	Recorder bracket	/	/
2.	/	Cross recessed pan head self-tapping screw PT3x8	/	/
3.	TR6F-30-67306	TR6F recorder	801-6800-00080-00	/
4.	/	Screw, Phillips M3x6, with washer	/	/

**8.2.13 Battery charge board assembly (12 inch)**

**8.2.13.1 Exploded View**

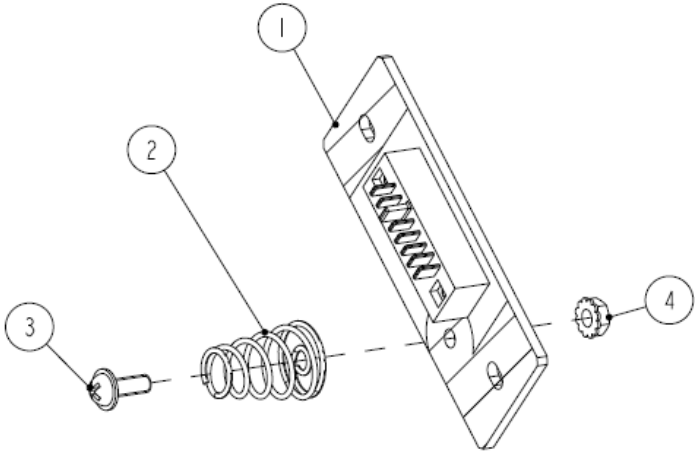

### 8.2.13.2 Parts List

SN	PN	Description	FRU part number	Remarks
1.	/	6301 battery interface PCBA	051-000891-00	/
2.	/	Battery spring	/	/
3.	/	Screw, Pan head with washer, Phillips M3×8	/	/
4.	/	M3 nut with spring washer	/	/

## 8.3 iMEC10/iMEC6

### 8.3.1 Main unit

#### 8.3.1.1 Exploded View

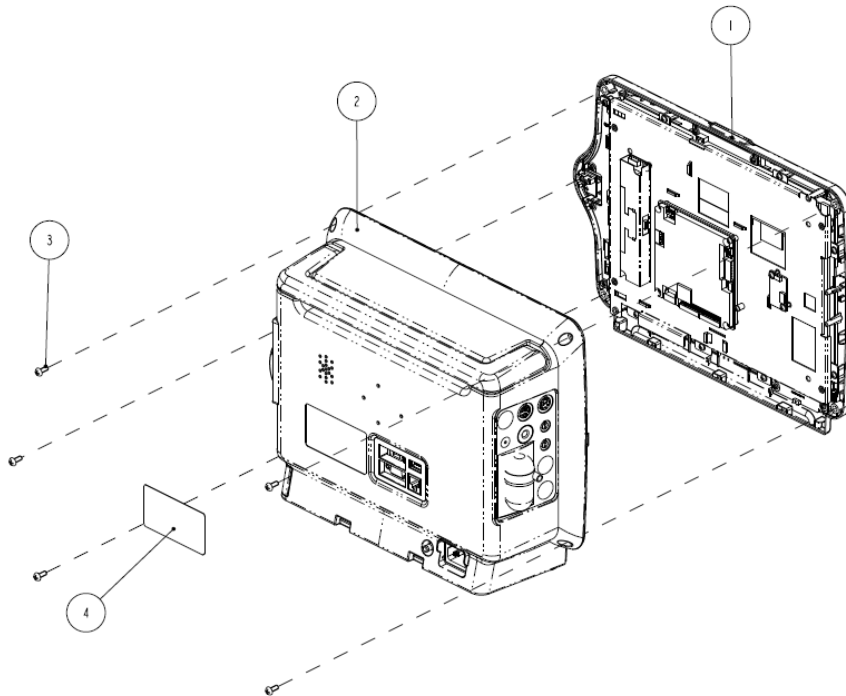

#### 8.3.1.2 Parts List

SN	PN	Description	FRU part number	Remarks
1.	/	Front panel assembly (12 Inch)	/	As configured
		Front panel assembly (10 Inch)	/	
2.	/	Rear housing assembly (12 inch)	/	Use with tapping screws
3.	/	Screw, pan head Phillips, M4×10	/	/
4.	/	Main unit label	/	/

### 8.3.2 Front Panel Assembly (10 Inch/touchscreen/Wi-Fi+ 1G SD card)

#### 8.3.2.1 Exploded View

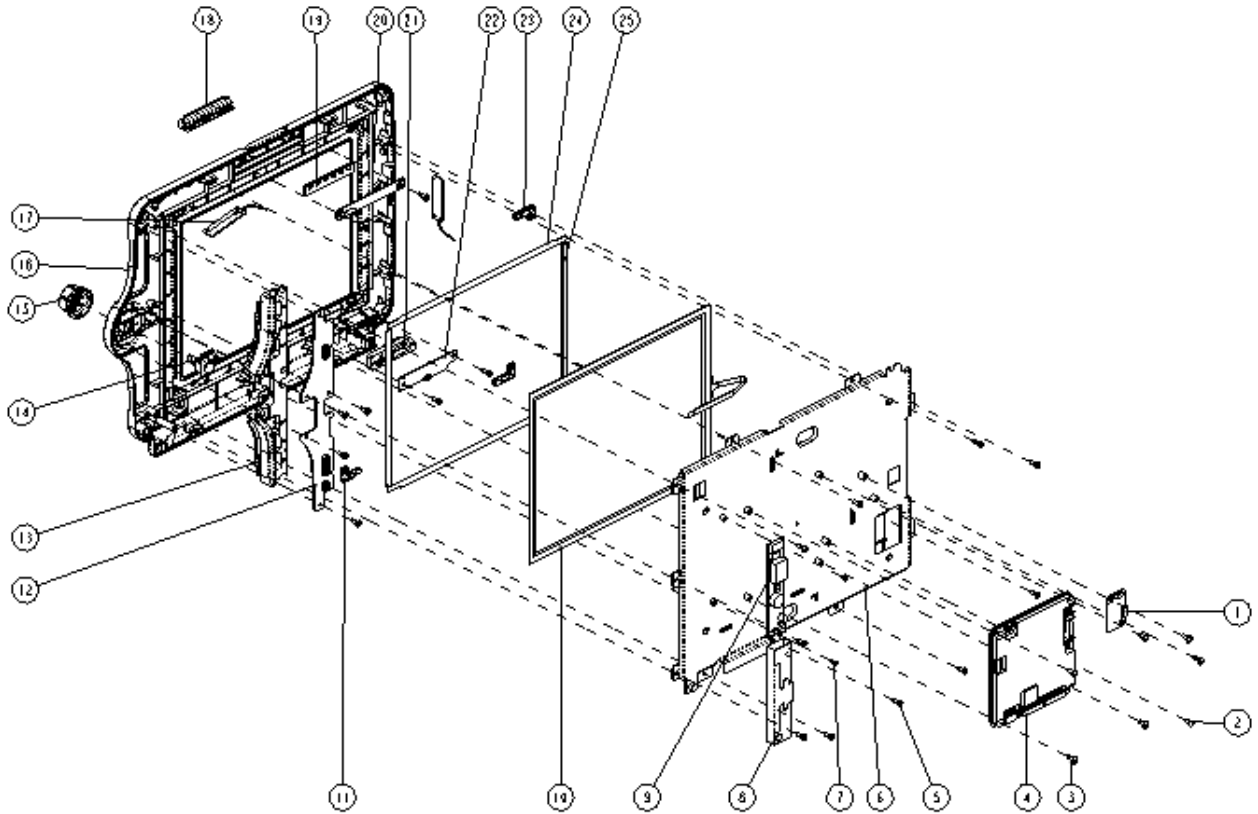

#### 8.3.2.2 Parts List

SN	PN	Description	FRU part number	Remarks
1.	/	Touchscreen control board PCBA	051-000881-00	/
2.	/	Screw, pan head Phillips, M3×6	/	/
3.	/	Screw, Pan head with washer, Phillips M3×8	/	/
4.	051-000829-00	Main board PCBA	801-6303-00001-00	/
5.	/	Screw, self-tapping, PT3×8	/	/
6.	/	Fujitsu touch screen kit (10 Inch LCD)	/	/
7.	/	Screw, pan head Phillips, M2×6	/	/
8.	/	Backlight board insulator	/	/
9.	/	Inverter, 12VDC/500Vrms 6mA signal output	022-000070-00	/
10.	/	Touch panel, resistive-type, 10.4" 4-line	021-000005-00	/
11.	/	DMC touchscreen position pad	/	/
12.	/	6301 keypad PCBA 12.1 inch	051-000878-00	/
13.	/	Key (12 inch, Chinese)	049-000335-00	As configured
	/	Key (12 inch, English)	049-000351-00	
	/	Key (12 inch, Italian)	049-000385-00	
	/	Key (12 inch, Spanish)	049-000386-00	

SN	PN	Description	FRU part number	Remarks
	/	Key (12 inch, Portuguese)	049-000387-00	
	/	Key (12 inch, French)	049-000388-00	
	/	Key (12 inch, German)	049-000389-00	
14.	/	Encoder board	0010-30-43089	/
15.	/	Knob	043-001790-00	/
16.	043-001973-01	Front housing (10 inch)	801-6303-00005-00	For monitors with machine screws
		Front housing (10 inch)	801-6303-00012-00	For monitors with tapping screws
17.	/	Antenna and cable assembly	115-010845-00	/
18.	/	Alarm lamp shade	/	/
19.	/	Alarm lamp gasket	/	/
20.	051-000879-01	Alarm lamp board PCBA	801-6301-00005-00	/
21.	/	Power button	6802-20-66691-51	/
22.	/	6301 On/Off key board PCBA	051-000880-00	/
23.	/	FUJI touchscreen position pad (10 inch)	/	/
24.	/	10 inch touchscreen long gasket	/	/
25.	/	10 inch touchscreen short gasket	/	/

### 8.3.3 Fujitsu Touchscreen Kit (10 Inch LCD)

#### 8.3.3.1 Exploded View

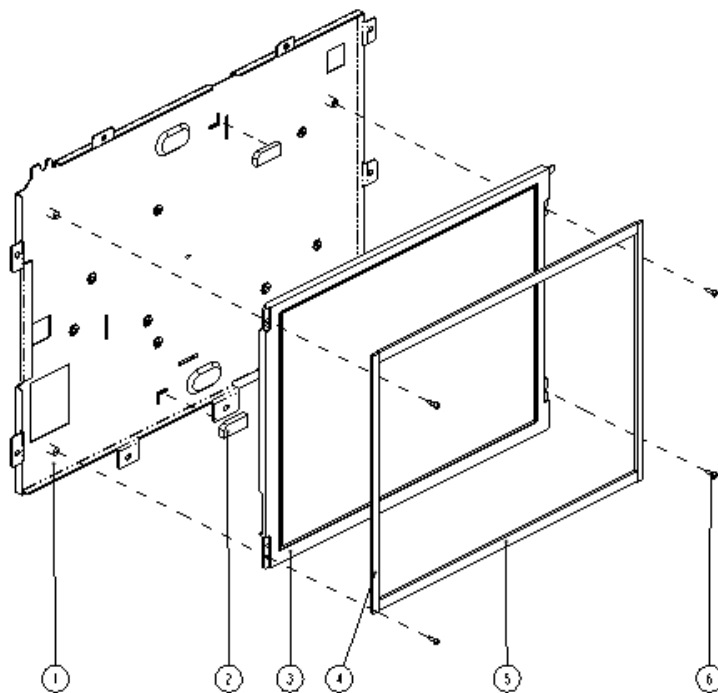



### 8.3.3.2 Parts List

SN	PN	Description	FRU part number	Remarks	
1.	/	Screen bracket 2 (10 inch touchscreen)	/	/	
2.	/	10 inch display buffer cushion (nakescreen)	/	/	
3.	021-000014-00	LCD, TFT10.4", 800×600	801-6303-00010-00	Main	As configured/Not mutually compatible nor exchangeable
	021-000062-00	LCD, TFT, 10.4", 800*600, LED-BackLight	801-6303-00003-00	Backup	
4.	/	Touchscreen pressing strip 4 (10 inch)	/	/	
5.	/	Touchscreen pressing strip 3 (10 inch)	/	/	
6.	/	Screw, pan head Phillips, M2×6	/	/	

### 8.3.4 Front Housing Assembly (10 Inch)

#### 8.3.4.1 Exploded View

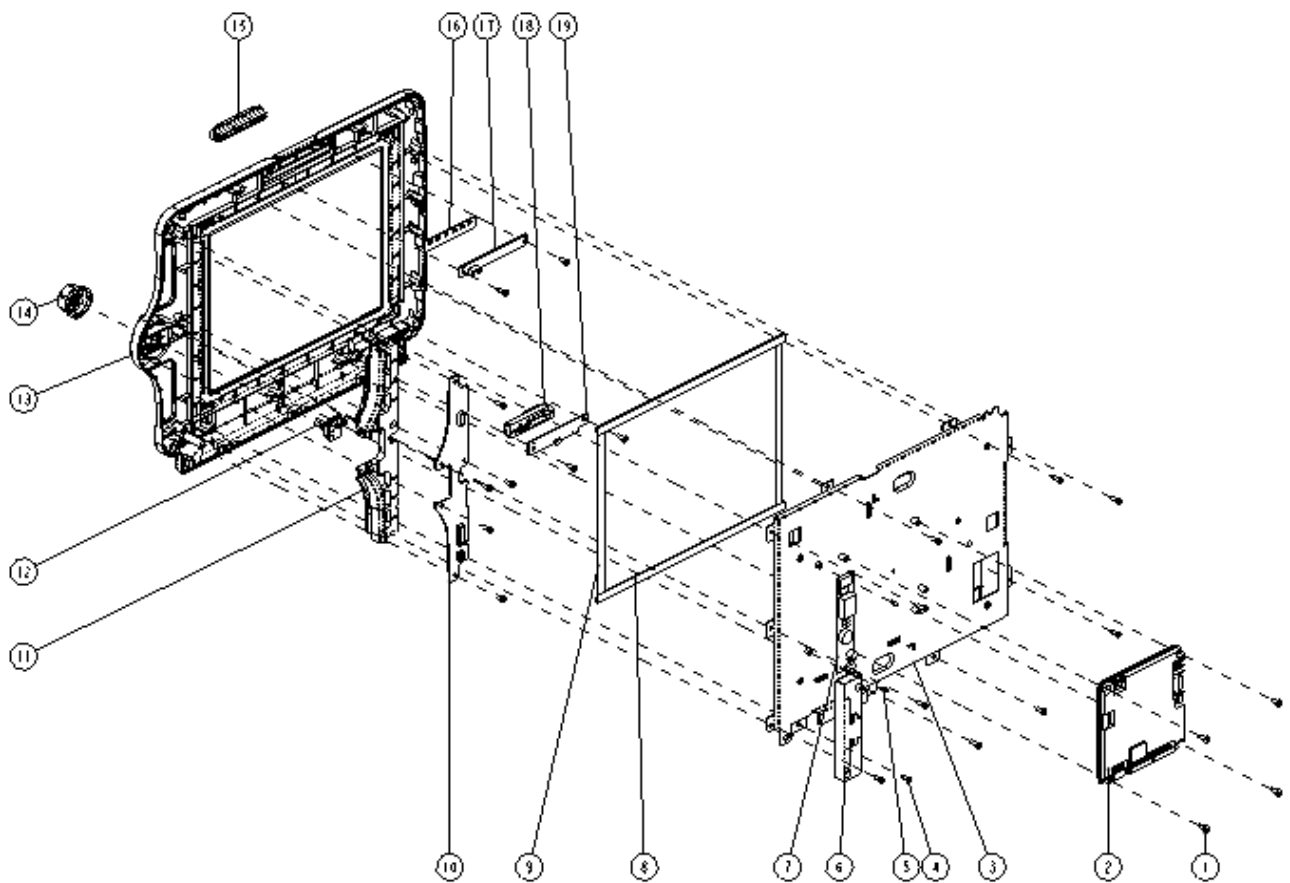

### 8.3.4.2 Parts List

SN	PN	Description	FRU part number	Remarks
1.	/	Screw, Pan head with washer, Phillips M3×8	/	/
2.	051-000964-00	6301 Main board PCBA (Standard configuration)	801-6303-00002-00	/
3.	/	Tianma LCD display kit (10 inch)	/	/
4.	/	Screw, self-tapping, PT3×8	/	/
5.	/	Screw, pan head Phillips, M2×6	/	/
6.	/	Backlight board insulator	/	/
7.	/	Inverter, 12VDC/500Vrms 6mA signal output	022-000070-00	/
8.	/	10 inch nakescreen long gasket	/	/
9.	/	10 inch nakescreen short gasket	/	/
10.	/	6301 keypad PCBA 12.1 inch	051-000878-00	/
11.	/	Key (12 inch, Chinese)	049-000335-00	As configured
	/	Key (12 inch, English)	049-000351-00	
	/	Key (12 inch, Italian)	049-000385-00	
	/	Key (12 inch, Spanish)	049-000386-00	
	/	Key (12 inch, Portuguese)	049-000387-00	
	/	Key (12 inch, French)	049-000388-00	
	/	Key (12 inch, German)	049-000389-00	
12.	/	Encoder board	0010-30-43089	/
13.	043-001973-01	Front housing (10 inch)	801-6303-00004-00	For monitors with machine screws
		Front housing (10 inch)	801-6303-00011-00	For monitors with tapping screws
14.	/	Knob	043-001790-00	/
15.	/	Alarm lamp shade	/	/
16.	/	Alarm lamp gasket	/	/
17.	051-000879-01	Alarm lamp board PCBA	801-6301-00005-00	/
18.		Power button	6802-20-66691-51	/
19.		6301 On/Off key board PCBA	051-000880-00	/

### 8.3.5 Tianma LCD display kit (10 inch)

#### 8.3.5.1 Exploded View

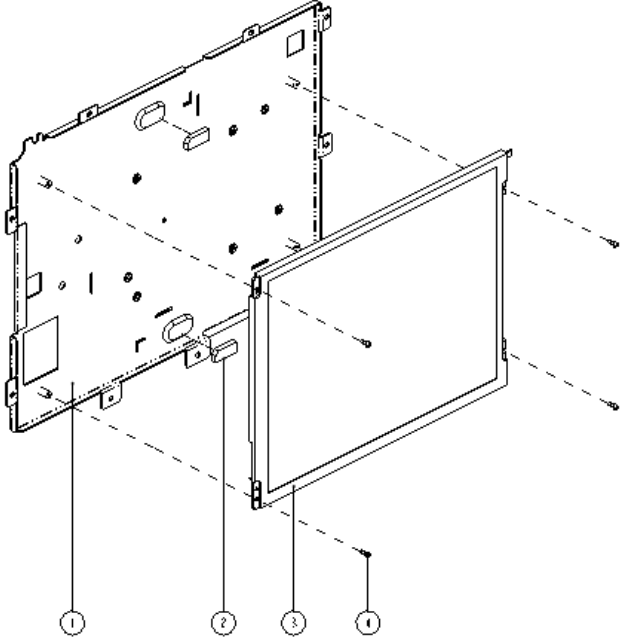

#### 8.3.5.2 Parts List

SN	PN	Description	FRU part number	Remarks
1.	/	LCD display bracket 1 (10 inch touchscreen)	/	/
2.	/	10 inch display buffer cushion (nakescreen)	/	/
3.	021-000014-00	LCD, TFT10.4", 800×600 (Tianma)	801-6303-00013-00	As configured/Not mutually compatible nor exchangeable
	/	LCD, TFT 10.4", 800×600 (AU)	021-000062-00	
4.	/	Screw, pan head Phillips, M2×6	/	/

### 8.3.6 Rear Housing Assembly

#### 8.3.6.1 Exploded View

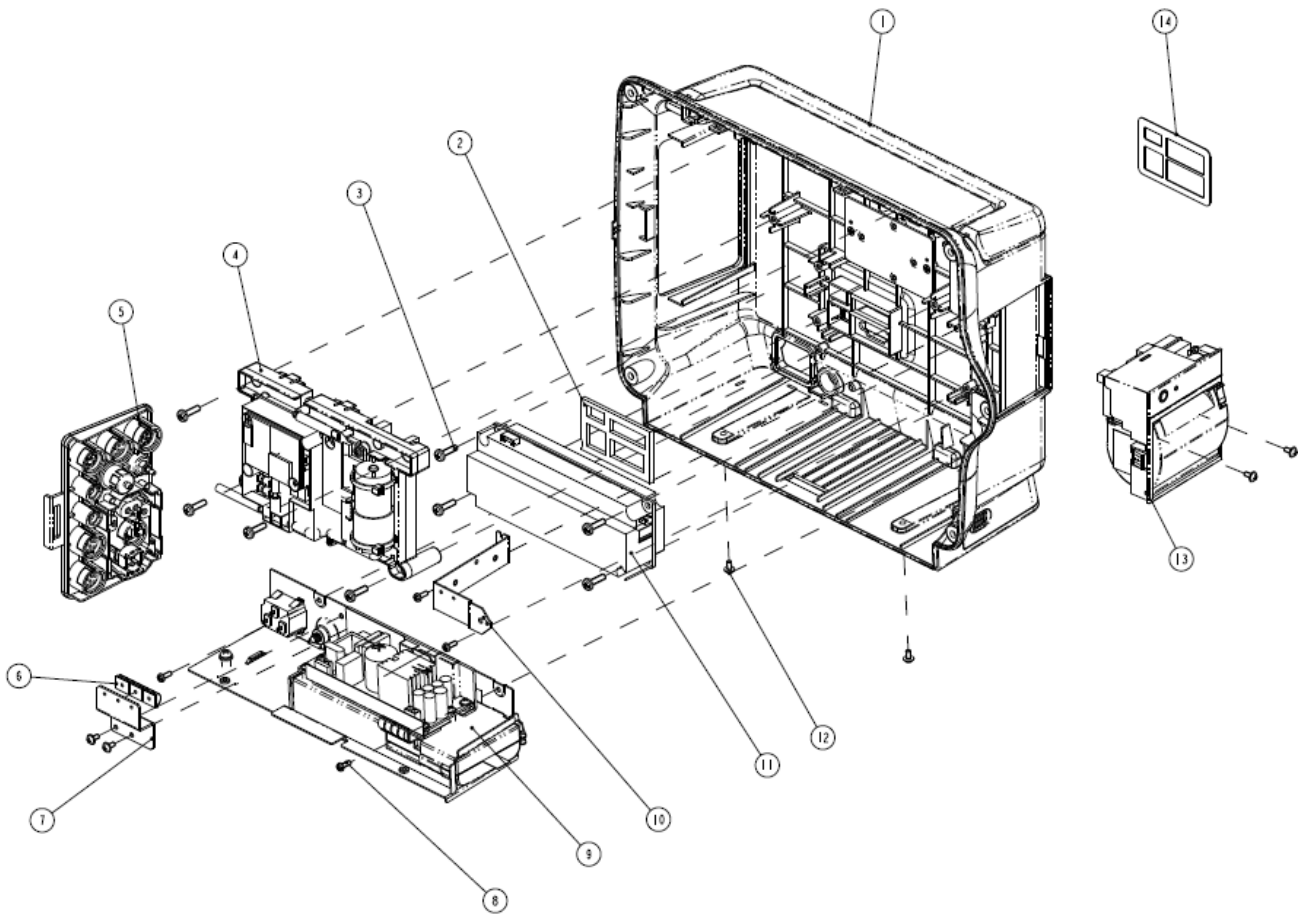

#### 8.3.6.2 Parts List

SN	PN	Description	FRU part number	Remarks
1.	/	Rear Housing Assembly (12 Inch)	115-010374-00	Use with tapping screws
2.	/	Interface board gasket	/	/
3.	/	Screw, self-tapping, PT4x14	/	/
4.	/	Parameter module assembly (ECG+Temp+NIBP+Mindray SpO <sub>2</sub> )	/	As configured
	/	Parameter module assembly (ECG+Temp+NIBP+Nellcor SpO <sub>2</sub> )	/	
	/	Parameter module assembly (ECG+Temp+NIBP+Masimo SpO <sub>2</sub> )	/	
	/	Parameter module assembly (ECG+Temp+NIBP+Mindray SpO <sub>2</sub> +IBP)	/	
	/	Parameter module assembly (ECG+Temp+NIBP+Nellcor SpO <sub>2</sub> +IBP)	/	

SN	PN	Description	FRU part number	Remarks
	/	Parameter module assembly (ECG+Temp+NIBP+Mindray SpO <sub>2</sub> +analog output)	/	
5.	/	Parameter connector assembly (ECG+Temp+NIBP+Mindray SpO <sub>2</sub> )	115-010355-00	As configured
	/	Parameter connector assembly (ECG+Temp+NIBP+Nellcor SpO <sub>2</sub> )	115-010356-00	
	/	Parameter connector assembly (ECG+Temp+NIBP+Masimo SpO <sub>2</sub> )	115-010357-00	
	/	Parameter connector assembly (ECG+Temp+NIBP+Mindray SpO <sub>2</sub> +IBP)	115-010358-00	
	/	Parameter connector assembly (ECG+Temp+NIBP+Nellcor SpO <sub>2</sub> +IBP)	115-010359-00	
	/	Parameter connector panel assembly (ECG+Temp+NIBP+Masimo SpO <sub>2</sub> +IBP)	115-010360-00	
6.	/	Spring, EMI	/	/
7.	/	Earth bracket	/	Optional
8.	/	Screw, self-tapping, PT3×8	/	/
9.	/	Battery compartment subassembly (12 inch)	115-010373-00	/
10.	/	Recorder bracket (12 inch)	/	/
11.	051-000850-00	PCBA,6301 Power management/interface board	801-6303-00001-00	As configured
	051-000965-00	6301 Interface board PCBA (STD)	801-6303-00002-00	
12.	/	Screw, Pan head with washer, Phillips M3×6	/	/
13.	TR6F-30-67306	TR6F recorder	801-6800-00080-00	/
	/	Recorder door	9211-20-87402	/
14.	/	IO label (all)	/	As configured
		IO label	/	

### 8.3.7 Rear Housing Assembly

#### 8.3.7.1 Exploded View

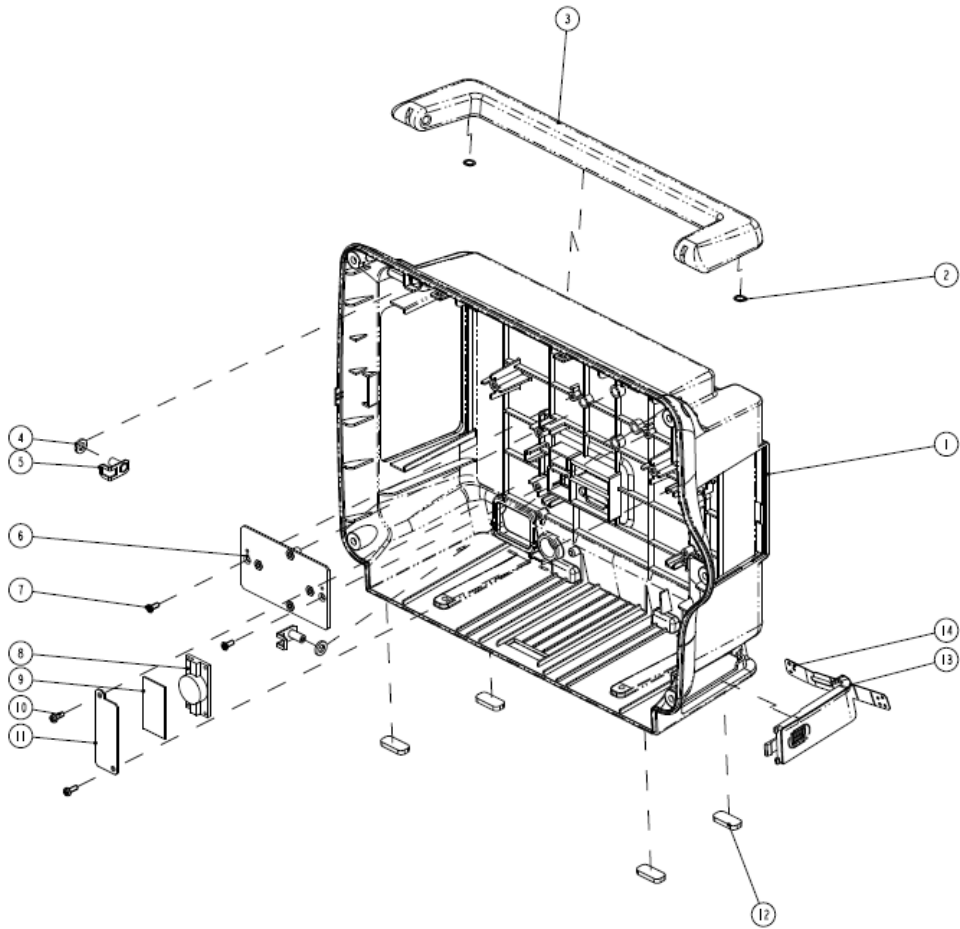

#### 8.3.7.2 Parts List

SN	PN	Description	FRU part number	Remarks
1.	043-001970-01	Rear housing (12 inch)	115-010374-00	/
2.	/	Buffer washer, Bumpon SJ5302 white and transparent	/	/
3.	043-001800-00	Handle (12 inch)	801-6301-00011-00	/
4.	/	Handle waterproof pad	/	/
5.	/	Handle bracket	/	/
6.	/	Hook bracket	/	/
7.	/	Screw, FT3x8, self-tapping	/	/
8.	/	Speaker, 2W, 4ohm, 60mm	020-000015-00	/
9.	/	Gasket, speaker pressure plate and spacer	/	/
10.	/	Screw, self-tapping, PT3x8	/	/
11.	/	Gasket, speaker spacer	/	/
12.	/	Rubber feet	/	/
13.	/	Battery door (12 inch)	115-010376-00	/
14.	/	Battery door belt		

## 8.3.8 Battery Compartment Assembly

### 8.3.8.1 Exploded View

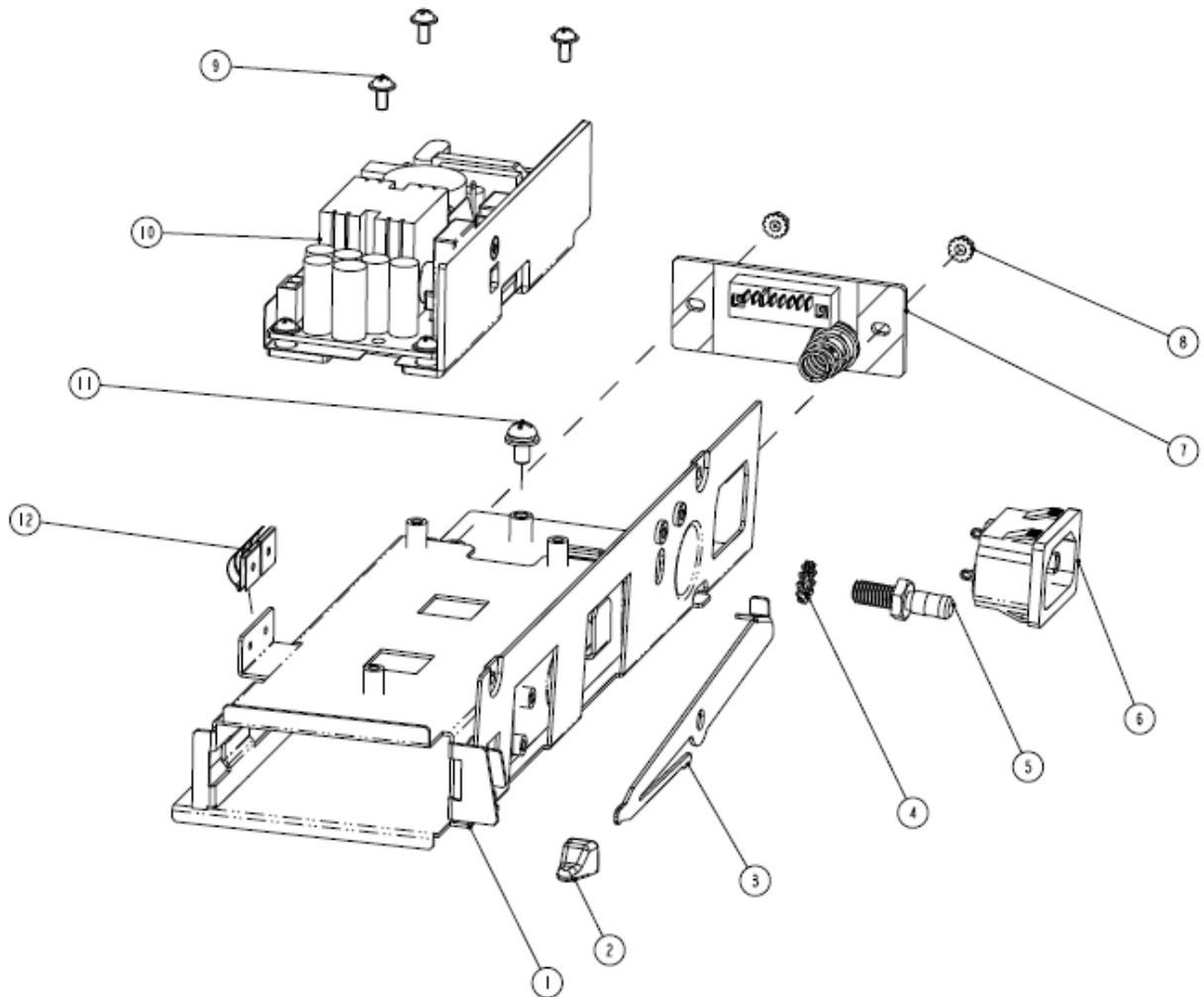

### 8.3.8.2 Parts List

SN	PN	Description	FRU part number	Remarks
1.	/	Main bracket (12 inch)	/	/
2.	/	Knob, battery latch	/	/
3.	/	Battery spring washer	/	/
4.	/	Serrated lock washers external teeth 6	/	/
5.	/	Grounding terminal	/	/
6.	/	Cable for AC input receptacle	009-002107-00	/
7.	/	Battery interface board	051-000891-00	/
8.	/	M3 nut with spring washer	/	/
9.	/	Screw, Pan head with washer, Phillips M3x6	/	/
10.	/	6301 AC/DC power PCBA	051-001064-00	/
11.	/	M4x8 combined screw	/	/
12.	/	Spring, EMI	/	/

### **8.3.9 Parameter Module Assembly**

For the exploded view and parts list of the parameter module assembly, refer to Section **8.2.7 Parameter module assembly**.

### **8.3.10 Parameter Connector Assembly**

For the exploded view and parts list of the parameter connector assembly, refer to Section **8.2.8 Parameter connector panel assembly**.

### **8.3.11 Mindray Sidestream CO<sub>2</sub> Module Kit**

For the exploded view and parts list of Mindray sidestream CO<sub>2</sub> module assembly, refer to Section **8.2.9 Mindray Sidestream CO<sub>2</sub> Module Kit**.

### **8.3.12 Oridion Microstream CO<sub>2</sub> Module Kit**

For the exploded view and parts list of Oridion microstream CO<sub>2</sub> module assembly, refer to Section **8.2.10 Oridion Microstream CO<sub>2</sub> Module Kit**.

### **8.3.13 Capnostat Mainstream CO<sub>2</sub> Module Kit**

For the exploded view and parts list of Capnostat mainstream CO<sub>2</sub> module assembly, refer to Section **8.2.11 Capnostat Mainstream CO<sub>2</sub> module kit**.

### **8.3.14 TR6F Recorder Kit**

For the exploded view and parts list of the TR6F recorder kit, refer to Section **8.2.12 TR6F Recorder Kit**.

### **8.3.15 Battery Interface Board Assembly**

For the exploded view and parts list of the battery interface board assembly, refer to Section **8.2.13 Battery charge board assembly (12 inch)**.

## **8.4 iMEC12/iMEC7**

### **8.4.1 Main Unit**

For the exploded view and parts list of the main unit, refer to Section **8.3.1 Main unit**.



## 8.4.2 Front Panel Assembly (12 Inch/touchscreen/Wi-Fi+ 1G SD card)

### 8.4.2.1 Exploded View

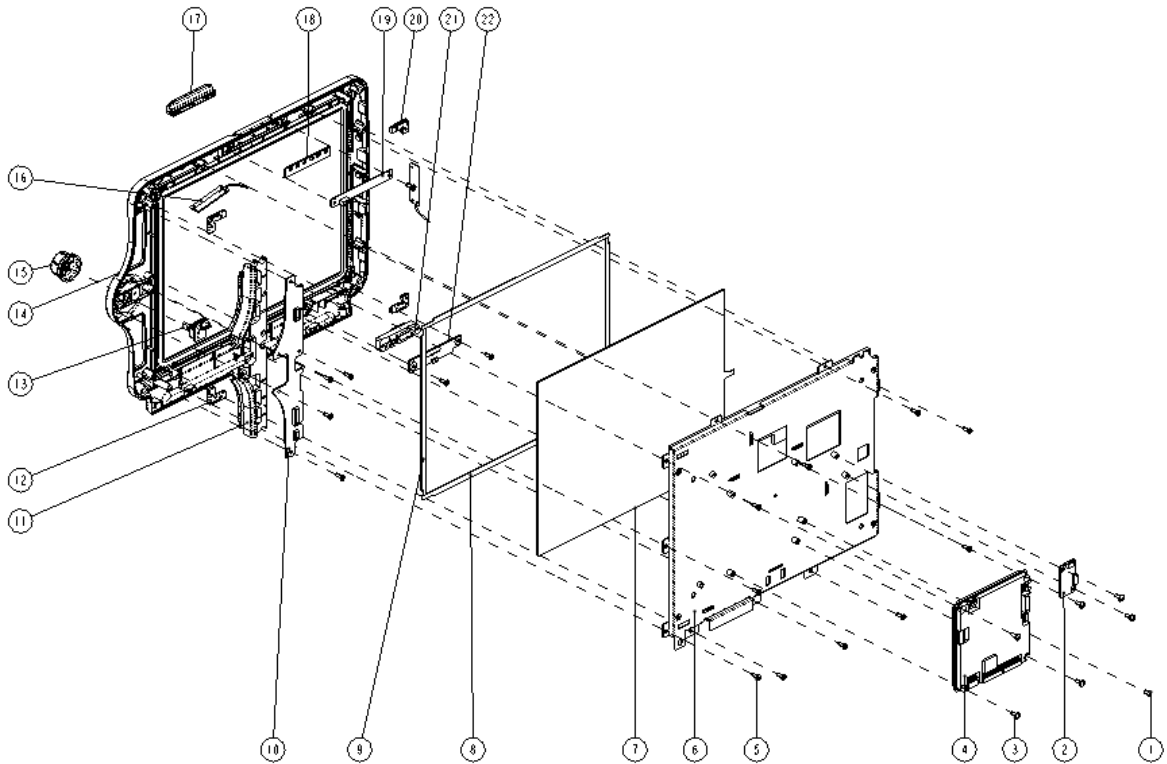

### 8.4.2.2 Parts List

SN	PN	Description	FRU part number	Remarks
1.	/	Screw, pan head Phillips, M3×6	/	/
2.	/	Touchscreen control board PCBA	051-000881-00	/
3.	/	Screw, Pan head with washer, Phillips M3×8	/	/
4.	051-000829-00	Main board PCBA	801-6302-00001-00	/
5.	/	Screw, self-tapping, PT3×8	/	/
6.	/	Fujitsu touchscreen kit (12 Inch)	/	/
7.	/	Touchscreen, resistive-type, 12.1" 4-line	021-000059-00	/
8.	/	12 inch touchscreen long gasket	/	/
9.	/	12 inch touchscreen short gasket	/	/
10.	/	6301 keypad PCBA 12.1 inch	051-000878-00	/
11.	/	Key (12 inch, Chinese)	049-000335-00	As configured
	/	Key (12 inch, English)	049-000351-00	
	/	Key (12 inch, Italian)	049-000385-00	
	/	Key (12 inch, Spanish)	049-000386-00	
	/	Key (12 inch, Portuguese)	049-000387-00	
	/	Key (12 inch, French)	049-000388-00	
	/	Key (12 inch, German)	049-000389-00	

SN	PN	Description	FRU part number	Remarks
12.	/	FUJI 12 Touchscreen long position pad	/	/
13.	/	Encoder board	0010-30-43089	/
14.	043-001969-01	Front housing (12 inch)	801-6301-00010-00	For monitors with machine screws
		Front housing (12 inch)	801-6301-00030-00	For monitors with tapping screws
15.	/	Knob	043-001790-00	/
16.	/	Antenna and cable assembly	115-010845-00	/
17.	/	Alarm lamp shade	/	/
18.	/	Alarm lamp gasket	/	/
19.	051-000879-01	Alarm lamp board PCBA	801-6301-00005-00	/
20.	/	FUJI 12" Touchscreen long position pad	/	/
21.	/	Power button	6802-20-66691-51	/
22.	/	6301 On/Off key board PCBA	051-000880-00	/

### 8.4.3 Fujitsu touchscreen kit (12 Inch)

#### 8.4.3.1 Exploded View

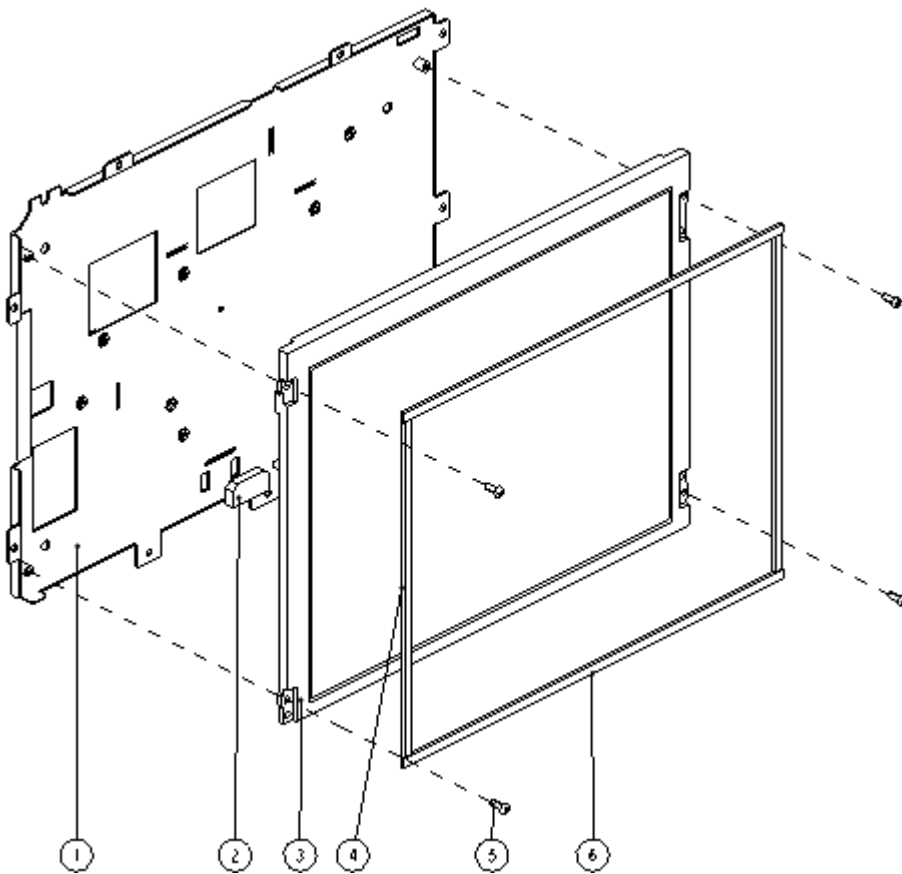

### 8.4.3.2 Parts List

SN	PN	Description	FRU part number	Remarks	
1.	/	Screen bracket (12 inch touchscreen)	/	/	
2.	/	12 inch AU display buffer cushion (touchscreen)	/	/	
3.	021-000083-00	LCD, TFT, 12.1", 800×600, 3.3V, LED-BackLight	801-6301-00025-00 (Tianma)	Main	As configured/Not mutually compatible nor exchangeable
	0010-10-42633	LCD, TFT, 12.1", 800×600, 3.3 V, LED-BackLight	801-6301-00024-00 (AU)	Backup	
	021-000061-00	LCD, TFT, 12.1", 800*600, LED-BackLight	801-6301-00008-00 (AU)	Backup	
4.	/	Short pressing strip 4 for 12 inch display bracket	/	/	
5.	/	Screw, pan head Phillips, M3×8	/	/	
6.	/	Short pressing strip 3 for 12 inch display bracket	/	/	

### 8.4.4 Front Housing Assembly (12 Inch)

#### 8.4.4.1 Exploded View

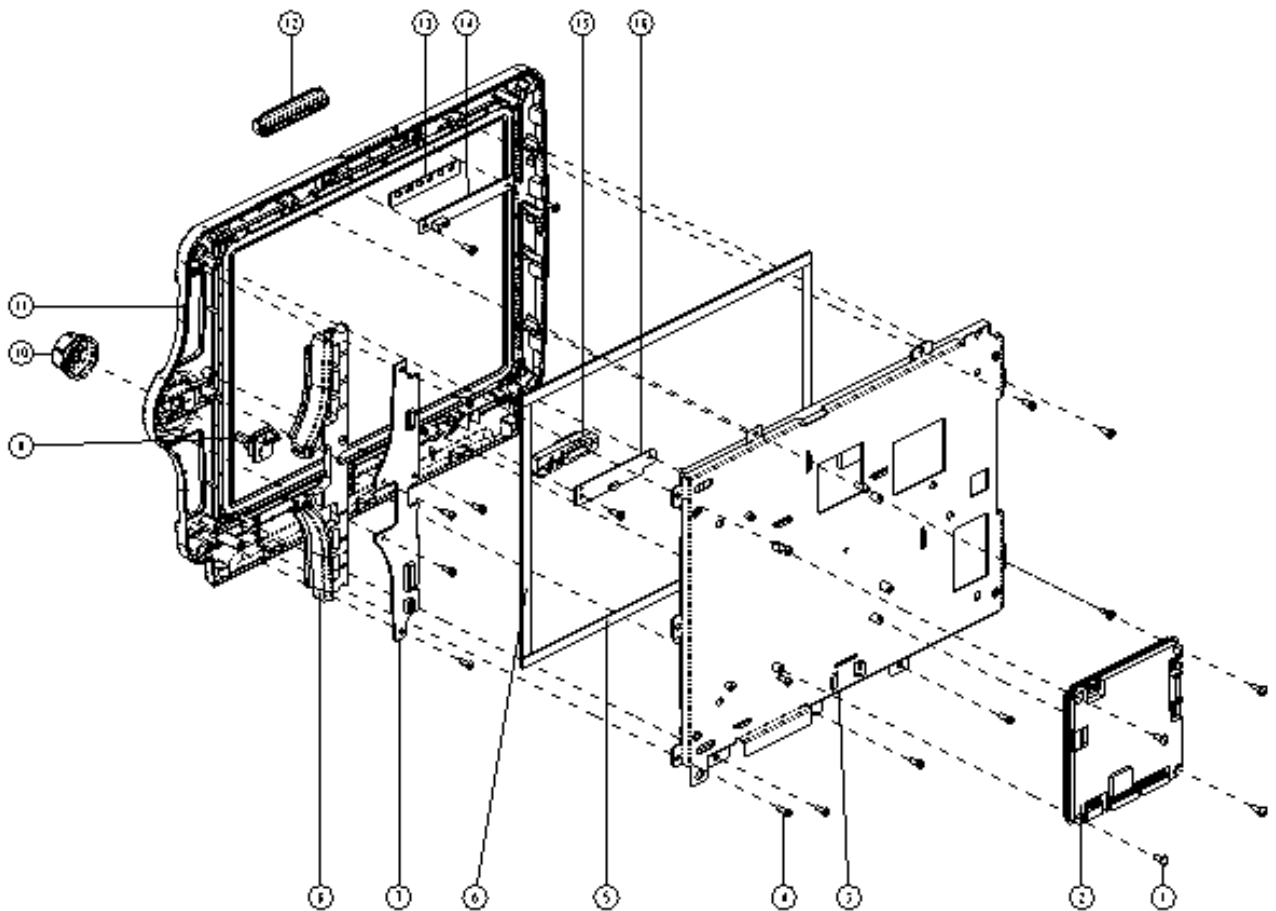

#### 8.4.4.2 Parts List

SN	PN	Description	FRU part number	Remarks
1.	/	Screw, Pan head with washer, Phillips M3×8	/	/
2.	051-000964-00	6301 Main board PCBA (Standard configuration)	801-6301-00004-00	/
3.	/	Tianma LCD display kit (12 inch)	/	/
4.	/	Screw, self-tapping, PT3×8	/	/
5.	/	12 inch nakescreen long gasket	/	/
6.	/	12 inch nakescreen short gasket	/	/
7.	/	6301 keypad PCBA 12.1 inch	051-000878-00	/
8.	/	Key (12 inch, Chinese)	049-000335-00	As configured
	/	Key (12 inch, English)	049-000351-00	
	/	Key (12 inch, Italian)	049-000385-00	
	/	Key (12 inch, Spanish)	049-000386-00	
	/	Key (12 inch, Portuguese)	049-000387-00	
	/	Key (12 inch, French)	049-000388-00	
	/	Key (12 inch, German)	049-000389-00	
9.	/	Encoder board	0010-30-43089	/
10.	/	Knob	043-001790-00	/
11.	043-001969-01	Front housing (12 inch)	801-6301-00009-00	For monitors with machine screws
		Front housing (12 inch)	801-6301-00029-00	For monitors with tapping screws
12.	/	Alarm lamp shade	/	/
13.	/	Alarm lamp gasket	/	/
14.	051-000879-01	Alarm lamp board PCBA	801-6301-00005-00	/
15.	/	Power button	6802-20-66691-51	/
16.	/	6301 On/Off key board PCBA	051-000880-00	/

## 8.4.5 Tianma LCD Display Kit (12 Inch)

### 8.4.5.1 Exploded View

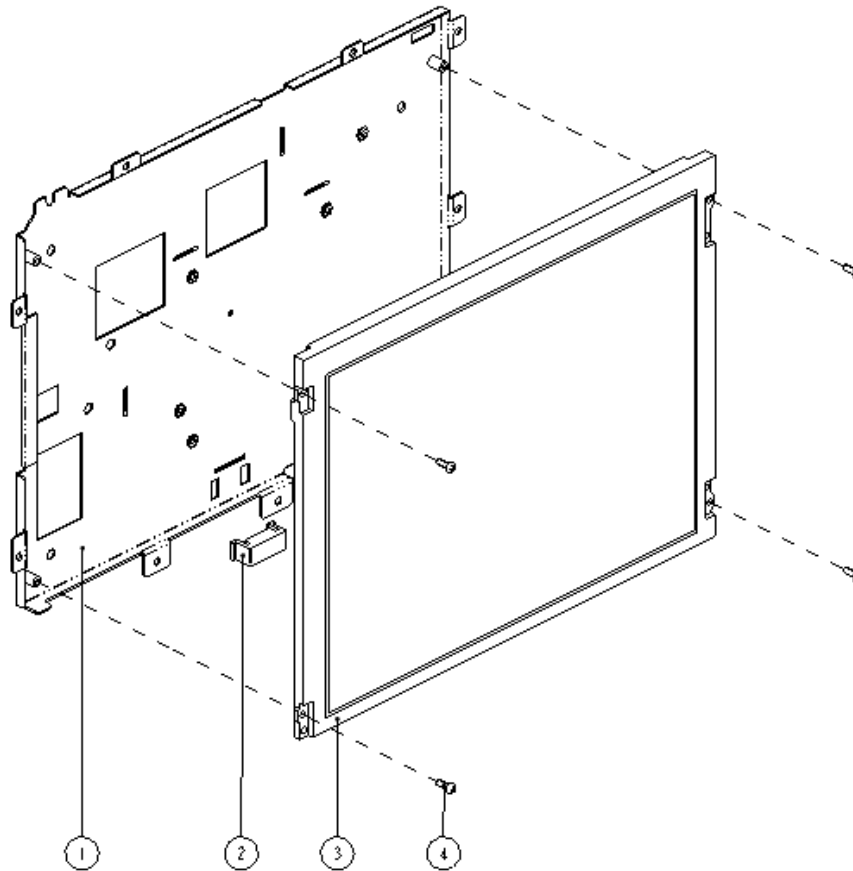

### 8.4.5.2 Parts List

SN	PN	Description	FRU part number	Remarks	
1.	/	Display bracket (12 inch nakescreen)	/	/	
2.	/	Nakescreen supporter	/	/	
3.		LCD, TFT, 12.1", 800×600, 3.3V, LED-BackLight	021-000083-00	Main	As configured/Not mutually compatible nor exchangeable
		LCD, TFT, 12.1", 800×600, 3.3 V, LED-BackLight	0010-10-42633	Backup	
		LCD, TFT, 12.1", 800*600, LED-BackLight	021-000061-00	Backup	
4.	/	Screw, pan head Phillips, M3×8	/	/	

### 8.4.6 Rear Housing Assembly

For the exploded view and parts list of the rear housing assembly, refer to Section **8.4.6 Rear Housing Assembly**.

### 8.4.7 Rear Housing Subassembly

For the exploded view and parts list of the rear housing subassembly, refer to Section **8.3.7 Rear Housing Assembly**.

#### **8.4.8 Battery Compartment Assembly**

For the exploded view and parts list of the battery compartment assembly, refer to Section **8.3.8 Battery Compartment Assembly**.

#### **8.4.9 Parameter Module Assembly**

For the exploded view and parts list of the parameter module assembly, refer to Section **8.2.7 Parameter module assembly**.

#### **8.4.10 Parameter Connector Assembly**

For the exploded view and parts list of the parameter connector assembly, refer to Section **8.2.8 Parameter connector panel assembly**.

#### **8.4.11 Mindray Sidestream CO<sub>2</sub> Module Kit**

For the exploded view and parts list of Mindray sidestream CO<sub>2</sub> module assembly, refer to Section **8.2.9 Mindray Sidestream CO<sub>2</sub> Module Kit**.

#### **8.4.12 Oridion Microstream CO<sub>2</sub> Module Kit**

For the exploded view and parts list of Oridion microstream CO<sub>2</sub> module assembly, refer to Section **8.2.10 Oridion Microstream CO<sub>2</sub> Module Kit**.

#### **8.4.13 Capnostat Mainstream CO<sub>2</sub> Module Kit**

For the exploded view and parts list of Capnostat mainstream CO<sub>2</sub> module assembly, refer to Section **8.2.11 Capnostat Mainstream CO<sub>2</sub> module kit**.

#### **8.4.14 TR6F Recorder Kit**

For the exploded view and parts list of the TR6F recorder kit, refer to Section **8.2.12 TR6F Recorder Kit**.

#### **8.4.15 Battery Interface Board Assembly**

For the exploded view and parts list of the battery interface board assembly, refer to Section **8.2.13 Battery charge board assembly (12 inch)**.

## 8.5 iMEC15/iMEC15S

### 8.5.1 Front Panel Assembly

#### 8.5.1.1 Exploded View

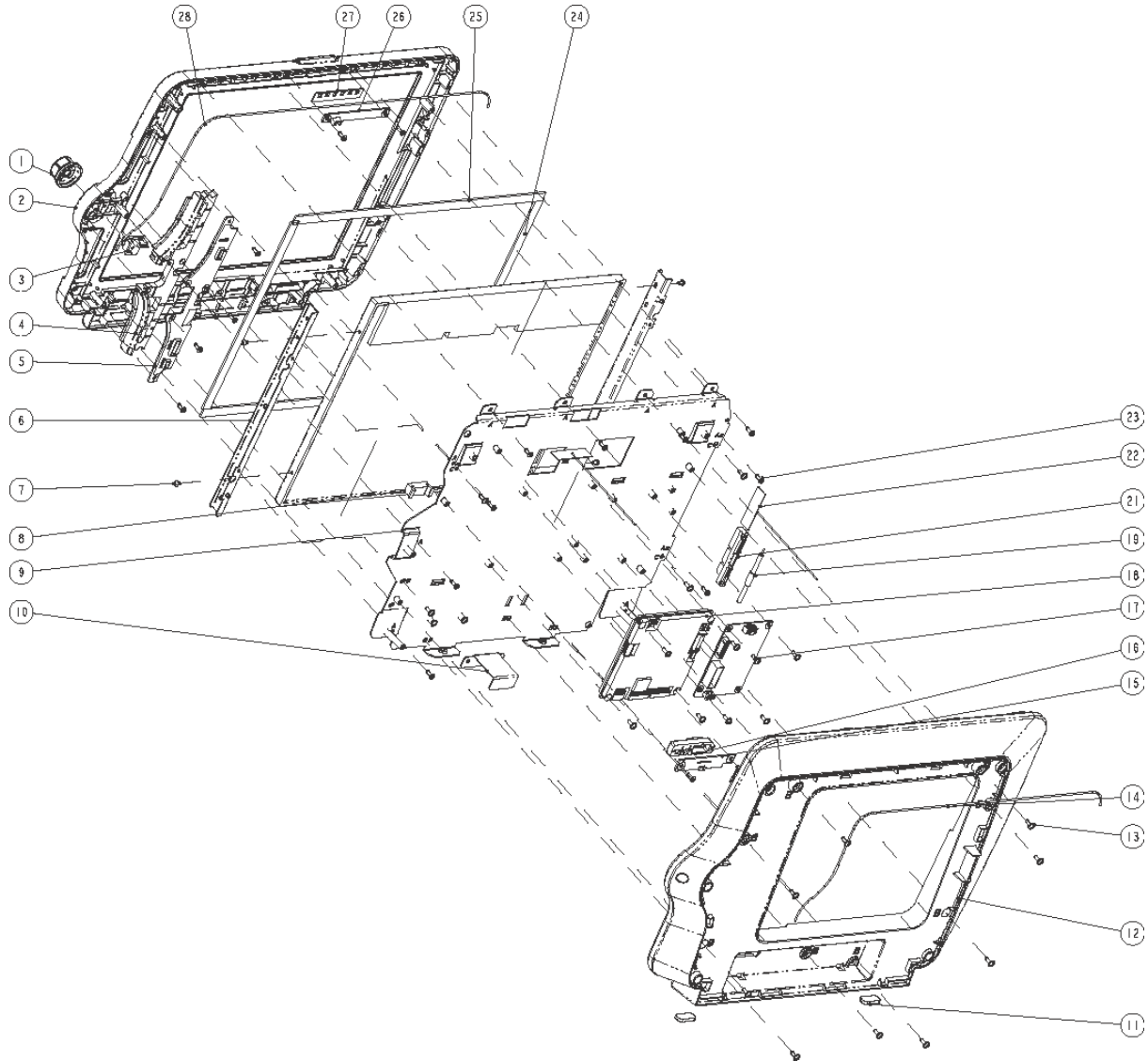

#### 8.5.1.2 Parts List

SN	PN	Description	FRU part number	Remarks
1.	/	Knob	043-001790-00	/
2.	/	iMEC15 front cover screen silk	043-006506-00	/
3.	/	Encoder board	0010-30-43089	/
4.	/	Key (12 inch)	049-000314-00	/
5.	/	6301 keyboard(12.1 inch) PCBA	051-000878-00	/
6.	/	Exposed screen frame side, iMEC15	042-014766-00	/
7.	/	Screw M3X4	M04-051001-01	/
8.	/	Nake screen lip block	049-000336-00	/

SN	PN	Description	FRU part number	Remarks
9.	/	Screen frame, iMEC15	042-014764-00	/
10.	/	ESD metal sheet, iMEC15	042-014767-00	/
11.	/	Rubber feet,T8	6800-20-50233	/
12.	/	Middle housing, iMEC15	043-006252-00	/
13.	/	Cross pan head screw	M04-004015---	/
14.	/	Silica gel piping	M6G-020015-450	/
15.	/	Power button and indicator board	6802-30-66680	/
16.	/	Power button, T5	6802-20-66691	/
17.	/	iMEC Display extended board PCBA	051-002157-00	/
18.	/	6308 main board PCBA	051-033015-00	/
19.	/	Wifi antenna 2.4 GHz/5 GHz	024-000717-00	/
20.	/	LCD TFT 15" 1024*768 3.3v led-bl	021-000162-00	/
21.	/	Antenna holder	049-001020-00	/
22.	/	Antenna cable	0012-00-1730-01	/
23.	/	Screw, Self-Tapping PT3X8	M04-003105---	/
24.	/	Screen gasket short, iMEC15	047-015086-00	/
25.	/	Screen gasket long, iMEC15	047-015085-00	/
26.	/	6301 alarmboard PCBA	051-000879-01	/
27.	/	Alarm gasket	047-005534-01	/
28.	/	Silica gel piping	M6G-020015-555	/



## 8.5.2 LCD Display Kit

### 8.5.2.1 Exploded View

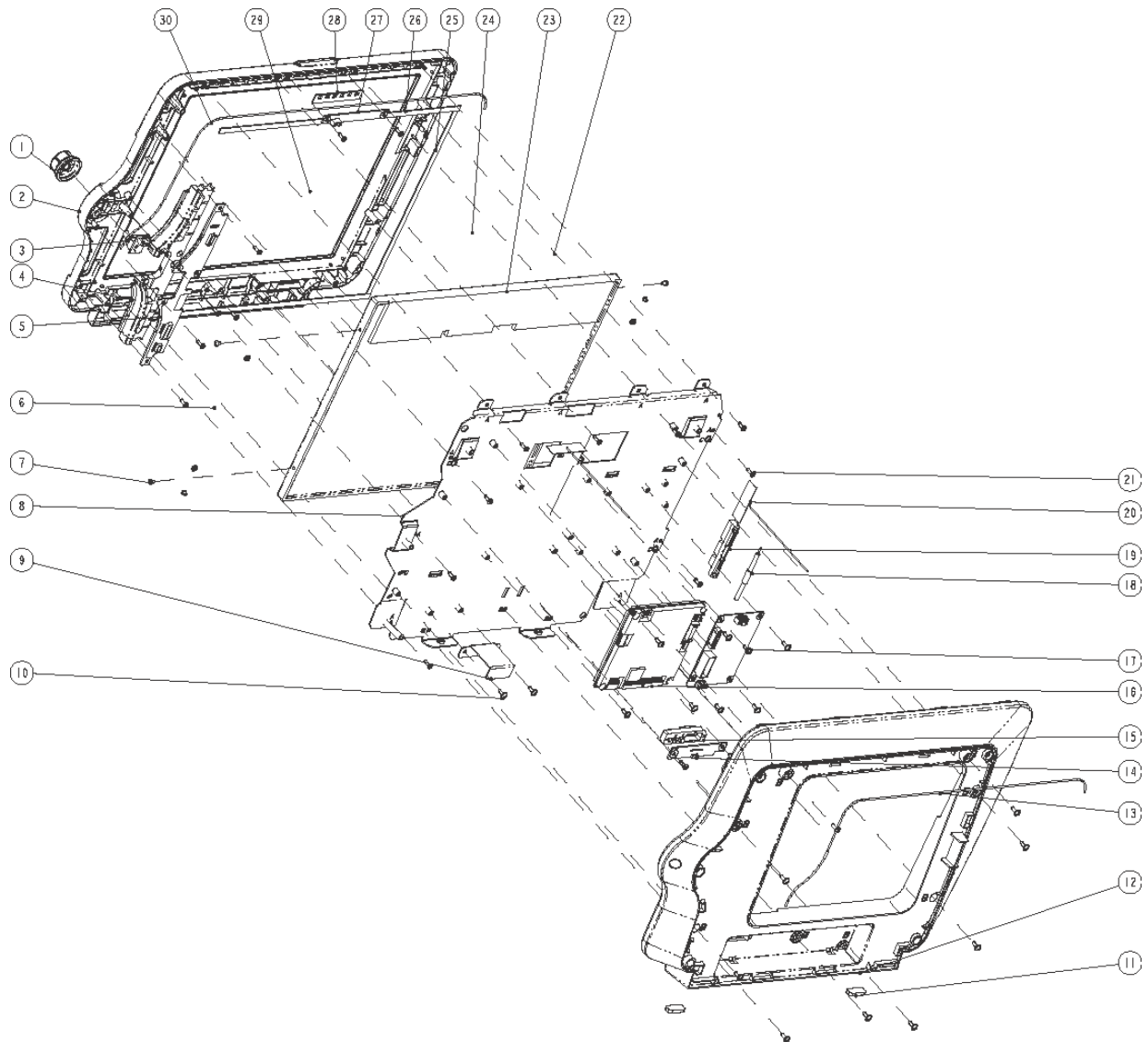

### 8.5.2.2 Parts List

SN	PN	Description	FRU part number	Remarks
1.	/	Knob	043-001790-00	/
2.	/	iMEC15 front cover screen silk	043-006506-00	/
3.	/	Encoder board	0010-30-43089	/
4.	/	Key (12 inch)	049-000314-00	/
5.	/	6301 keyboard(12.1 inch) PCBA	051-000878-00	/
6.	/	Screen frame side, iMEC15	042-014765-00	/
7.	/	Screw M3X4	M04-051001-01	/
8.	/	Screen frame, iMEC15	042-014764-00	/
9.	/	ESD metal sheet, iMEC15	042-014767-00	/
10.	/	Cross pan head screw	M04-004015---	/

<b>SN</b>	<b>PN</b>	<b>Description</b>	<b>FRU part number</b>	<b>Remarks</b>
11.	/	Rubber feet,T8	6800-20-50233	/
12.	/	Middle housing, iMEC15	043-006252-00	/
13.	/	Silica gel piping	M6G-020015-450	/
14.	/	Power button and indicator board	6802-30-66680	/
15.	/	Power button, T5	6802-20-66691	/
16.	/	6308 main board PCBA	051-033015-00	/
17.	/	iMEC Display extended board PCBA	051-002157-00	/
18.				
19.	/	Antenna holder	049-001020-00	/
20.	/	Antenna cable	0012-00-1730-01	/
21.	/	Screw, Self-Tapping PT3X8	M04-003105---	/
22.	/	TP cushion long, iMEC15	047-015083-00	/
23.	/	LCD TFT 15" 1024*768 3.3v led-bl	021-000162-00	/
24.	/	TP cushion short, iMEC15	047-015084-00	/
25.	/	double-sided tape short, iMEC15	047-015434-00	/
26.	/	double-sided tape long, iMEC15	047-015433-00	/
27.	/	6301 alarmboard PCBA	051-000879-01	/
28.	/	Alarm gasket	047-005534-01	/
29.	/	Lens, iMEC15	047-015080-00	/
30.	/	Silica gel piping	M6G-020015-555	/

## 8.5.3 Touchscreen Kit

### 8.5.3.1 Exploded View

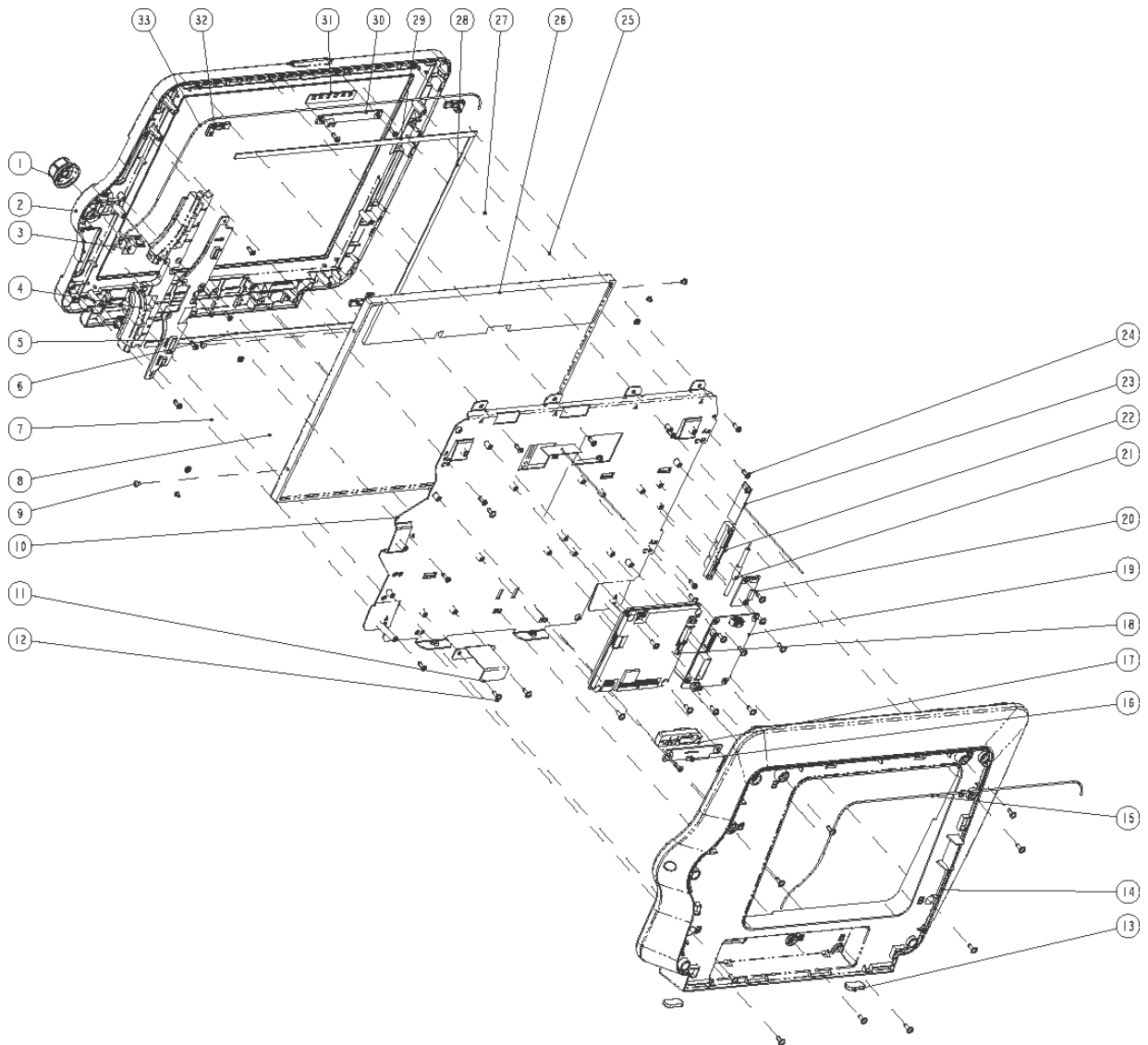

### 8.5.3.2 Parts List

SN	PN	Description	FRU part number	Remarks
1.	/	Knob	043-001790-00	/
2.	/	iMEC15 front cover screen silk	043-006506-00	/
3.	/	Encoder board	0010-30-43089	/
4.	/	Key (12 inch)	049-000314-00	/
5.	/	6301 keyboard(12.1 inch) PCBA	051-000878-00	/
6.	/	double-sided tape long, iMEC15	047-015433-00	/
7.	/	Screen frame side, iMEC15	042-014765-00	/
8.	/	TP cushion short, iMEC15	047-015084-00	/
9.	/	Screw M3X4	M04-051001-01	/
10.	/	Screen frame, iMEC15	042-014764-00	/

<b>SN</b>	<b>PN</b>	<b>Description</b>	<b>FRU part number</b>	<b>Remarks</b>
11.	/	ESD metal sheet, iMEC15	042-014767-00	/
12.	/	Cross pan head screw	M04-004015---	/
13.	/	Rubber feet,T8	6800-20-50233	/
14.	/	Middle housing, iMEC15	043-006252-00	/
15.	/	Silica gel piping	M6G-020015-450	/
16.	/	Power button and indicator board	6802-30-66680	/
17.	/	Power button, T5	6802-20-66691	/
18.	/	6308 main board PCBA	051-033015-00	/
19.	/	iMEC Display extended board PCBA	051-002157-00	/
20.	/	Touchscreen control board PCBA	051-000881-00	/
21.	/	Wifi antenna 2.4 GHz/5 GHz	024-000717-00	/
22.	/	Antenna holder	049-001020-00	/
23.	/	Antenna cable	0012-00-1730-01	/
24.	/	Screw, Self-Tapping PT3X8	M04-003105---	/
25.	/	TP cushion long, iMEC15	047-015083-00	/
26.	/	LCD TFT 15" 1024*768 3.3v led-bl	021-000162-00	/
27.	/	Touchscreen pressing strip 4	021-000211-00	/
28.	/	TP gasket short, iMEC15	047-015082-00	/
29.	/	TP gasket long, iMEC15	047-015081-00	/
30.	/	6301 alarmboard PCBA	051-000879-01	/
31.	/	Alarm gasket	047-005534-01	/
32.	/	Fuji10 touchscreen position pad	049-000341-00	/
33.	/	Silica gel piping	M6G-020015-555	/

## 8.6 Other Maintainable Parts

No.	PN	Description	FRU part number	Remarks
1.	/	Mainstream CO <sub>2</sub> signal cable	009-001994-00	/
2.	/	M02C sidestream communication cable	009-001995-00	/
3.	/	Cable between interface board and C.O. module	009-001996-00	/
4.	/	Cable between the interface board and mainstream converter board	009-001997-00	/
5.	/	Cable between the interface board and microstream converter board	009-001998-00	/
6.	/	Recorder cable	009-002000-00	/
7.	/	Cable for AC/DC module	009-002108-00	/
8.	/	Cable for touchscreen control board	009-002109-00	/
9.	/	8.4" AU display cable	009-002110-00	As configured
	/	Display signal cable (Truly, 8")	009-002468-00	
10.	/	Cable for display signal (AU 10")	009-002111-00	/
11.	/	Cable for display signal (AU 12")	009-002112-00	/
12.	/	8" AU display backlight cable	009-002113-00	/
13.	/	10.4" AU display backlight cable	009-002114-00	/
14.	/	Cable for backlight of 12.1" display (AU)	009-002115-00	/
15.	/	Alarm lamp cable	009-002116-00	/
16.	/	Cable between main board and keypad board	009-002117-00	/
17.	/	Cable between keypad and power board	009-002118-00	/
18.	/	Cable between parameter board and interface board	009-002119-00	/
19.	/	Cable between main board and interface board	009-002126-00	/
20.	/	Cable for ON/OFF key board (12")	009-002127-00	/
21.	/	Cable for battery backboard	009-002132-00	/
22.	/	Cable between inverter and main board (10")	009-002469-00	/
23.	/	Display signal cable (Tianma, 10")	009-002471-00	/
24.	/	Encoder cable	9200-21-10460	/
25.	/	TFT display backboard cable	8000-21-10239	/
26.	/	Silicon, white	M6G-020015--	/
27.	/	Main board PCBA (full configuration, 12 inch)	801-6301-00003-00	/
28.	/	Cyberlink module PCBA	051-000811-00	/

**FOR YOUR NOTES**

# A Electrical Safety Inspection

---

The following electrical safety tests are recommended as part of a comprehensive preventive maintenance program. They are a proven means of detecting abnormalities that, if undetected, could prove dangerous to either the patient or the operator. Additional tests may be required according to local regulations.

All tests can be performed using commercially available safety analyzer test equipment. These procedures assume the use of a 601PROXL International Safety Analyzer or equivalent safety analyzer. Other popular testers complying with IEC 60601-1 used in Europe, such as Fluke, Metron, or Gerb, may require modifications to the procedure. Please follow the instructions of the analyzer manufacturer.

The consistent use of a safety analyzer as a routine step in closing a repair or upgrade is emphasized as a mandatory step if an approved agency status is to be maintained. The safety analyzer also proves to be an excellent troubleshooting tool to detect abnormalities of line voltage and grounding, as well as total current loads.

## A.1 Power Cord Plug

Test Item		Acceptance Criteria
The power plug	The power plug pins	No broken or bent pin. No discolored pins.
	The plug body	No physical damage to the plug body.
	The strain relief	No physical damage to the strain relief. No plug warmth for device in use.
	The power plug	No loose connections.
The power cord		No physical damage to the cord. No deterioration to the cord.
		For devices with detachable power cords, inspect the connection at the device.
		For devices with non-detachable power cords, inspect the strain relief at the device.

## A.2 Device Enclosure and Accessories

### A.2.1 Visual Inspection

Test Item	Acceptance Criteria
The enclosure and accessories	No physical damage to the enclosure and accessories.
	No physical damage to meters, switches, connectors, etc.
	No residue of fluid spillage (e.g., water, coffee, chemicals, etc.).
	No loose or missing parts (e.g., knobs, dials, terminals, etc.).

### A.2.2 Contextual Inspection

Test Item	Acceptance Criteria
The enclosure and accessories	No unusual noises (e.g., a rattle inside the case).
	No unusual smells (e.g., burning or smoky smells, particularly from ventilation holes).
	No taped notes that may suggest device deficiencies or operator concerns.

## A.3 Device Labeling

Check the labels provided by the manufacturer or the healthcare facility are present and legible.

- Main unit label
- Integrated warning labels

## A.4 Protective Earth Resistance

Protective Earth Resistance is measured using the RED test lead attached to the DUT Protective Earth terminal or enclosure. Select the test current (25 amp) by pressing SOFT KEY 3. The front panel outlet power is turned off for this test.

The following conditions apply: L1 and L2 Open.

### Preparation

1. First select the test current that will be used for performing the Protective Earth Resistance test by pressing AMPERES (SOFT KEY 3).
2. Connect the test lead(s) between the RED input jack and the GREEN input jack.
3. Press CAL LEADS. The 601PRO will measure the lead resistance, and if less than 0.150 Ohms, it will store the reading and subtract it from all earth resistance readings taken at the calibrated current.

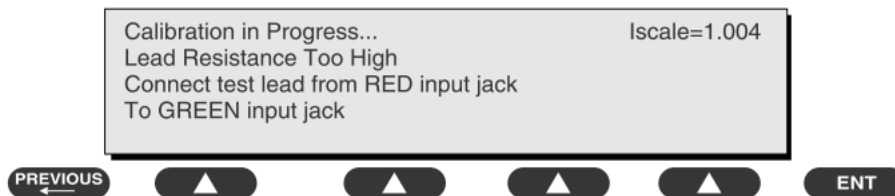

If the calibration fails, the previously stored readings will be used until a passing calibration has occurred.

---

### WARNING

- **During Earth Resistance testing, the DUT must be plugged into the 601PRO front outlet. If the DUT fails Earth Resistance, discontinue tests and label the device defective.**
- 

### To Perform the Test

1. From the MAIN MENU, or with the outlet unpowered, plug the DUT into the 601PRO front panel outlet.
2. Attach the 601PRO RED input lead to the device's Protective Earth terminal or an exposed metal area.
3. Press shortcut key 3. The Protective Earth Resistance test is displayed.



- Press SOFT KEY 3 to select a test current (25 amp). The selected test current is displayed in the upper right corner of the display.

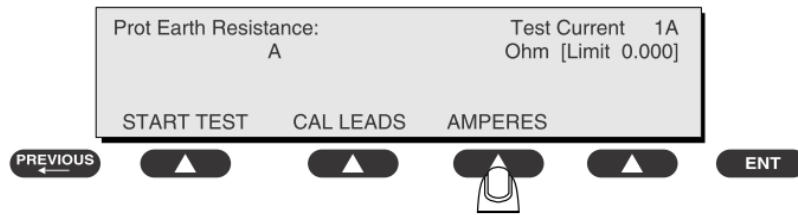

- Press START TEST to start the test. The test current is applied while resistance and current readings are taken. This takes approximately 5 seconds.
- Press the print data key at any time to generate a printout of the latest measurement(s).

## NOTE

- When "Over" is displayed for Ohms, this signifies that a valid measurement was not obtained because either an open connection was detected or that the measurement was not within range. Readings greater than 9.999 Ohms will be displayed as Over.

### In Case of Failure

Once it reaches the limitation, stop using and inform the Customer Service Engineer for analysis and disposal.

### LIMITS

ALL COUNTRIES R = 0.2  $\Omega$  Maximum

## A.5 Earth Leakage Test

Run an Earth Leakage test on the device being tested before performing any other leakage tests.

Leakage current is measured the following ways:

- Earth Leakage Current, leakage current measured through DUT outlet Earth
- Earth Leakage Current AP-EARTH (ALL Applied Parts connected to Earth), leakage current measured through DUT outlet Earth

There is no need to attach a test lead; the 601PRO automatically connects the measuring device internally.

### To Perform the Test

- From the MAIN MENU, or with the outlet unpowered, plug the DUT into the 601PRO front panel outlet, and turn on the device.
- Attach the device's applied parts to the 601PRO applied part terminals if applicable.

- Press shortcut key 4. The Earth Leakage test appears on the display, and the test begins immediately:

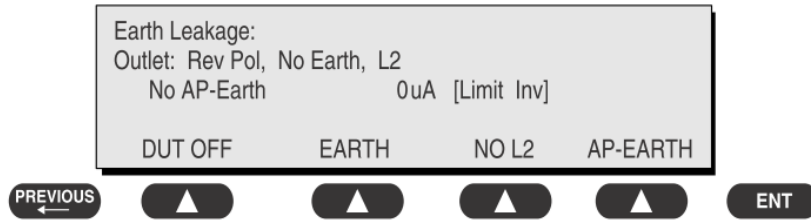

- SOFT KEY 1 toggles the DUT outlet Polarity from Normal to Off to Reverse.
  - SOFT KEY 2 toggles the DUT outlet from Earth to No Earth.
  - SOFT KEY 3 toggles the DUT outlet from L2 to No L2.
  - SOFT KEY 4 toggles the AP to Earth to No AP to Earth.
- Press the print data key at any time to generate a printout of the latest measurement.

### In Case of Failure

- Check any broken of the enclosure. Replace any defective part.
- Inspect wiring for bad crimps, poor connections, or damage.
- Test the wall outlet; verify it is grounded and is free of other wiring abnormalities. Notify the user or owner to correct any deviations. As a work around, check the other outlets to see if they could be used instead.
- Change another probe to confirm if the fail is caused by console.
- If the leakage current measurement tests fail on a new unit and if situation can not be corrected, submit a Safety Failure Report to document the system problem. Remove unit from operation.
- If all else fails, stop using and inform the Customer Service Engineer for analysis and disposal.

### LIMITS

For UL60601-1,

- ◆ 300  $\mu$ A in Normal Condition
- ◆ 1000  $\mu$ A in Single Fault Condition

For IEC60601-1,

- ◆ 500  $\mu$ A in Normal Condition
- ◆ 1000  $\mu$ A in Single Fault Condition

## A.6 Patient Leakage Current

Patient leakage currents are measured between a selected applied part and mains earth. All measurements have a true RMS only response.

### Preparation

Perform a calibration from the Mains on Applied Part menu.

The following outlet conditions apply when performing this test:

- Normal Polarity, Earth Open, Outlet ON Normal Polarity, Outlet ON
- Normal Polarity, L2 Open, Outlet ON Reversed Polarity, Outlet ON
- Reversed Polarity, Earth Open, Outlet ON Reversed Polarity, L2 Open, Outlet ON

---

---

## WARNING

---

- **If all of the applied parts correspond to the instrument type, the applied parts will be tied together and one reading will be taken. If any of the applied parts differ from the instrument type, all applied parts will be tested individually, based on the type of applied part. This applies to Auto and Step modes only.**
- 

### To Perform the Test

1. From the MAIN MENU, or with the outlet unpowered, plug the DUT into the 601PRO front panel outlet, and turn on the device.
2. Attach the applied parts to the 601PRO's applied part terminals.
3. Press shortcut key 6. The Patient Leakage test is displayed, and the test begins immediately.



4. Press APPLIED PART (SOFT KEY 4) at any time to select the desired applied part leakage current.
5. Modify the configuration of the front panel outlet by pressing the appropriate SOFT KEY on the 601PRO.
6. Press the print data key at any time to generate a printout of the latest measurement.

### In Case of Failure

- Check any broken of the enclosure. Replace any defective part.
- Inspect wiring for bad crimps, poor connections, or damage.
- Test the wall outlet; verify it is grounded and is free of other wiring abnormalities. Notify the user or owner to correct any deviations. As a work around, check the other outlets to see if they could be used instead.
- Change another probe to confirm if the fail is caused by console.
- If the leakage current measurement tests fail on a new unit and if situation can not be corrected, submit a Safety Failure Report to document the system problem. Remove unit from operation.
- If all else fails, stop using and inform the Customer Service Engineer for analysis and disposal.

### LIMITS

For CF  applied parts

- ◆ 10 $\mu$ A in Normal Condition
- ◆ 50 $\mu$ A in Single Fault Condition

For BF  applied parts

- ◆ 100µA in Normal Condition
- ◆ 500µA in Single Fault Condition

## A.7 Mains on Applied Part Leakage

The Mains on Applied Part test applies a test voltage, which is 110% of the mains voltage, through a limiting resistance, to selected applied part terminals. Current measurements are then taken between the selected applied part and earth. Measurements are taken with the test voltage (110% of mains) to applied parts in the normal and reverse polarity conditions as indicated on the display.

The following outlet conditions apply when performing the Mains on Applied Part test.

- Normal Polarity;
- Reversed Polarity

### Preparation

To perform a calibration from the Mains on Applied Part test, press CAL (SOFT KEY 2).

1. Disconnect ALL patient leads, test leads, and DUT outlet connections.
2. Press CAL to begin calibration, as shown:

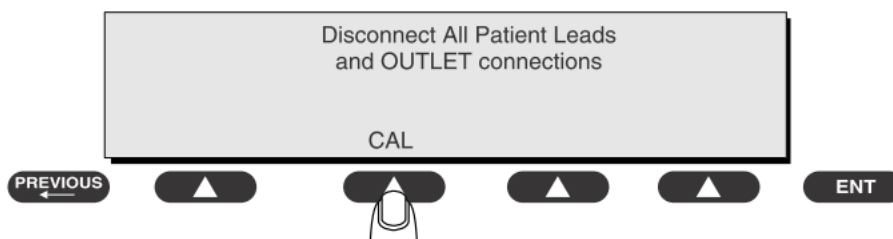

If the calibration fails, the previously stored readings will be used until a passing calibration has occurred. Also, the esc/stop key has no effect during calibration.

3. When the calibration is finished, the Mains on Applied Part test will reappear.

---

### WARNING

- A 2-beep-per-second signal indicates high voltage present at the applied part terminals while a calibration is being performed.
  - High voltage is present at applied part terminals while measurements are being taken.
-

## To Perform the Test

1. From the MAIN MENU, or with the outlet unpowered, plug the DUT into the 601
2. Attach the applied parts to the 601PRO applied part terminals.
3. Attach the red terminal lead to a conductive part on the DUT enclosure.
4. Press shortcut key 7. The Mains on Applied Part test is displayed.

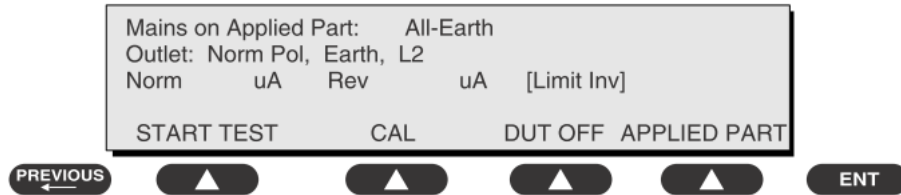

5. Select the desired outlet configuration and applied part to test using the appropriate SOFT KEYS:
6. Press START TEST (SOFT KEY 1) to begin the test.
7. Press the print data key to generate a printout of the latest measurement.

## NOTE

- **If all of the applied parts correspond to the instrument type, the applied parts will be tied together and one reading will be taken. If any of the applied parts differ from the instrument type, all applied parts will be tested individually, based on the type of applied part. This applies to Auto and Step modes only.**

## In Case of Failure

- Check any broken of the enclosure. Replace any defective part.
- Inspect wiring for bad crimps, poor connections, or damage.
- Test the wall outlet; verify it is grounded and is free of other wiring abnormalities. Notify the user or owner to correct any deviations. As a work around, check the other outlets to see if they could be used instead.
- Change another probe to confirm if the fail is caused by console.
- If the leakage current measurement tests fail on a new unit and if situation can not be corrected, submit a Safety Failure Report to document the system problem. Remove unit from operation.
- If all else fails, stop using and inform the Customer Service Engineer for analysis and disposal.

## LIMITS

- For CF  applied parts: 50  $\mu$ A
- For BF  applied parts: 5000  $\mu$ A

## A.8 Patient Auxiliary Current

Patient Auxiliary currents are measured between any selected ECG jack and the remaining selected ECG jacks. All measurements may have a true RMS only response.

## Preparation

1. From the MAIN MENU, or with the outlet unpowered, plug the DUT into the 601PRO front panel outlet, and turn on the device.
2. Attach the patient leads to the 601PRO ECG jacks.
3. Define the Lead Types from the View Settings Option (refer to: Lead Type Definitions in Section 5 of this chapter).
4. Press shortcut key 8. The Patient Auxiliary Current test is displayed, and the test begins immediately. Display values are continuously updated until another test is selected.

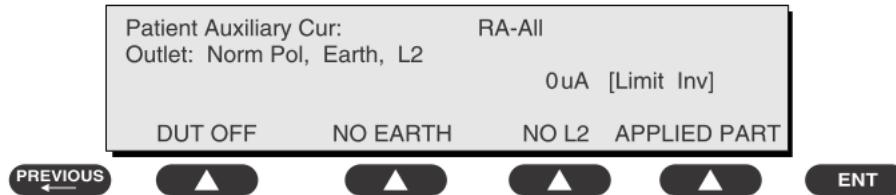

5. Press SOFT KEYS 1-4 to select leakage tests
6. Press APPLIED PART (SOFT KEY 4) at any time to select the desired applied part leakage current:
7. Modify the configuration of the front panel outlet by pressing the appropriate SOFT KEY on the 601PRO:
8. Press the print data key at any time to generate a printout of the latest measurement.

## In Case of Failure

- Check any broken of the enclosure. Replace any defective part.
- Inspect wiring for bad crimps, poor connections, or damage.
- Test the wall outlet; verify it is grounded and is free of other wiring abnormalities. Notify the user or owner to correct any deviations. As a work around, check the other outlets to see if they could be used instead.
- Change another probe to confirm if the fail is caused by console.
- If the leakage current measurement tests fail on a new unit and if situation can not be corrected, submit a Safety Failure Report to document the system problem. Remove unit from operation.
- If all else fails, stop using and inform the Customer Service Engineer for analysis and disposal.

## LIMITS

For CF  applied parts,

- ◆ 10 $\mu$ A in Normal Condition
- ◆ 50 $\mu$ A in Single Fault Condition

For BF  applied parts,

- ◆ 100 $\mu$ A in Normal Condition
- ◆ 500 $\mu$ A in Single Fault Condition

## A.9 Scheduled Electrical Safety Inspection

For scheduled electrical safety inspection, test items 1, 2, 3, 4, 5, 6, 7, and 8 included in the **ELECTRICAL SAFETY INSPECTION FORM** shall be performed.

### ELECTRICAL SAFETY INSPECTION FORM

<b>Location:</b>			<b>Technician:</b>	
<b>Equipment:</b>			<b>Control Number:</b>	
<b>Manufacturer:</b>		<b>Model:</b>		<b>SN:</b>
<b>Measurement equipment /SN:</b>			<b>Date of Calibration:</b>	
<b>INSPECTION AND TESTING</b>			<b>Pass/Fail</b>	<b>Limit</b>
1	Power Cord Plug			
2	Device Enclosure and Accessories			
3	Device Labeling			
4	Protective Earth Resistance		___Ω	Max 0.2 Ω
5	Earth Leakage	Normal condition (NC)	___μA	Max: NC: 300μA(refer to UL60601-1) * NC: 500μA(refer to IEC60601-1) * SFC: 1000μA
		Single Fault condition (SFC)	___μA	
6	Patient Leakage Current	Normal condition (NC)	<input type="checkbox"/> BF ___μA	Max: CF applied part: NC:10μA, SFC: 50μA BF applied part: NC:100μA, SFC: 500μA
			<input type="checkbox"/> CF ___μA	
		Single Fault condition (SFC)	<input type="checkbox"/> BF ___μA	
			<input type="checkbox"/> CF ___μA	
7	Mains on Applied Part Leakage		<input type="checkbox"/> BF ___μA	Max: CF applied part: 50μA BF applied part: 5000μA
			<input type="checkbox"/> CF ___μA	
8	Patient Auxiliary Current	Normal condition (NC)	<input type="checkbox"/> BF ___μA	Max: CF applied part: NC:10μA, SFC: 50μA BF applied part: NC:100μA, SFC: 500μA
			<input type="checkbox"/> CF ___μA	
		Single Fault condition (SFC)	<input type="checkbox"/> BF ___μA	
			<input type="checkbox"/> CF ___μA	

Note: The equipment sold to the United States shall comply with the requirement of UL60601-1; others shall comply with the requirement of IEC60601-1.

Name/ Signature: \_\_\_\_\_ Date: \_\_\_\_\_

## A.10 Electrical Safety Inspection after Repair

The following table specifies test items to be performed after the equipment is repaired.

<b>Repair with main unit not disassembled</b>		Test items: 1, 2, 3
<b>Repair with main unit disassembled</b>	When neither power supply PCBA nor patient electrically-connected PCBA is repaired or replaced	Test items: 1, 2, 3, 4
	When power supply PCBA is repaired or replaced	Test items: 1, 2, 3, 4, 5
	When patient electrically-connected PCBA is repaired or replaced	Test items: 1, 2, 3, 4, 6, 7, 8
	When both PCBA and patient electrically-connected PCBA are repaired or replaced	Test items: 1, 2, 3, 4, 5, 6, 7, 8



**ELECTRICAL SAFETY INSPECTION FORM**

<b>Location:</b>			<b>Technician:</b>	
<b>Equipment:</b>			<b>Control Number:</b>	
<b>Manufacturer:</b>		<b>Model:</b>		<b>SN:</b>
<b>Measurement equipment /SN:</b>			<b>Date of Calibration:</b>	
<b>INSPECTION AND TESTING</b>			<b>Pass/Fail</b>	<b>Limit</b>
1	Power Cord Plug			
2	Device Enclosure and Accessories			
3	Device Labeling			
4	Protective Earth Resistance		Ω	Max 0.2 Ω
5	Earth Leakage	Normal condition(NC)	____μA	Max: NC: 300μA(refer to UL60601-1) * NC: 500μA(refer to IEC60601-1) * SFC: 1000μA
		Single Fault condition(SFC)	____μA	
6	Patient Leakage Current	Normal condition(NC)	<input type="checkbox"/> BF____μA	Max: CF applied part: NC:10μA, SFC: 50μA BF applied part: NC:100μA, SFC: 500μA
			<input type="checkbox"/> CF____μA	
		Single Fault condition(SFC)	<input type="checkbox"/> BF____μA	
			<input type="checkbox"/> CF____μA	
7	Mains on Applied Part Leakage		<input type="checkbox"/> BF____μA	Max: CF applied part: 50μA BF applied part: 5000μA
			<input type="checkbox"/> CF____μA	
8	Patient Auxiliary Current	Normal condition(NC)	<input type="checkbox"/> BF____μA	Max: CF applied part: NC:10μA, SFC: 50μA BF applied part: NC:100μA, SFC: 500μA
			<input type="checkbox"/> CF____μA	
		Single Fault condition(SFC)	<input type="checkbox"/> BF____μA	
			<input type="checkbox"/> CF____μA	

Note: The equipment sold to the United States shall comply with the requirement of UL60601-1; others shall comply with the requirement of IEC60601-1.

Name/ Signature: \_\_\_\_\_ Date: \_\_\_\_\_

**FOR YOUR NOTES**



