

# 上墙支架使用说明书

## Wall Mount Operator's Manual



# 目 录

目 录 .....	i
<b>1 支架组件结构.....</b>	<b>1</b>
<b>2 安装.....</b>	<b>2</b>
2.1 导轨 .....	2
2.2 支撑臂 .....	13
2.3 适配器固定架 .....	24
2.4 储物篮 .....	26
<b>3 机械安全检查.....</b>	<b>27</b>
<b>1 Structure of Wall Mount.....</b>	<b>1</b>
<b>2 Installation .....</b>	<b>2</b>
2.1 Channel .....	2
2.2 Arm .....	16
2.3 Bracket of the adapter .....	27
2.4 Storage Basket .....	29
<b>3 Mechanical Safety Test.....</b>	<b>30</b>



# 1 支架组件结构

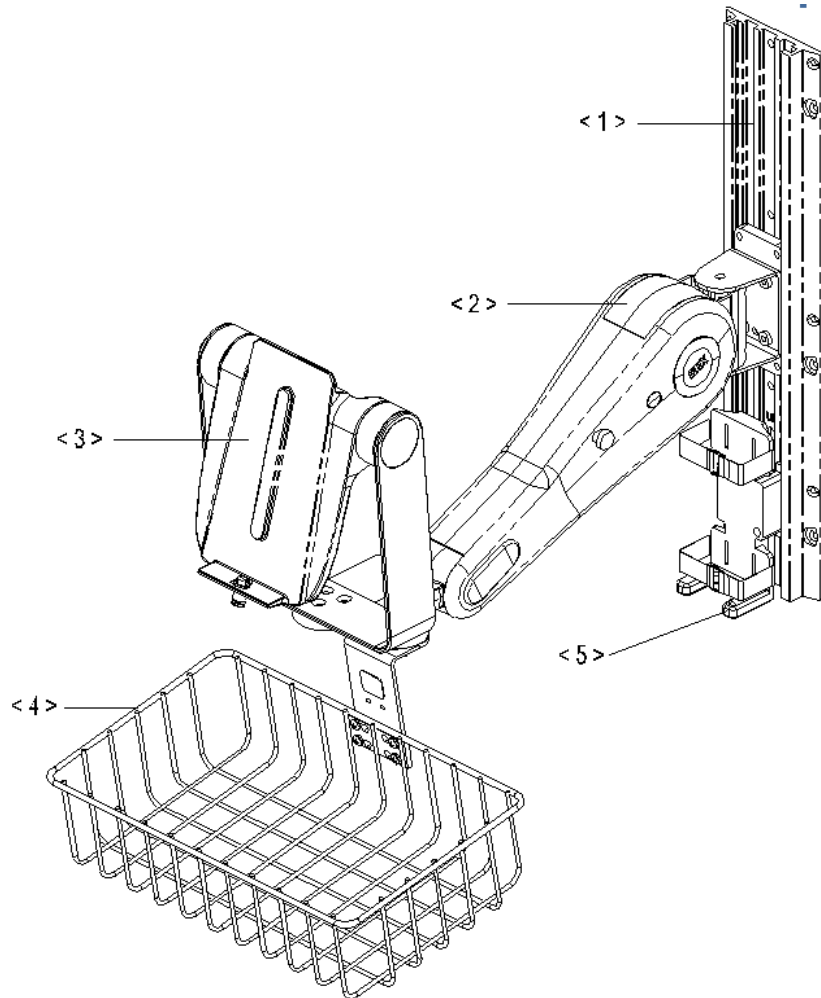

序号	名称	功能
1.	上墙支架导轨	将上墙支架固定到墙上 备注：可使用“吊塔固定转接件”替代“上墙支架导轨”，将上墙支架固定到吊塔上
2.	上墙支架支撑臂	调节上墙支架的角度
3.	主机固定支架	固定超声主机
4.	储物蓝	放置纸巾等杂物
5.	适配器固定架	固定主机外置适配器

# 2 安装

---

## 2.1 导轨

### 2.1.1 上墙导轨

#### 警告:

- 必须由专业人员进行安装，安装失败有可能引起严重的人身伤害。
- 在安装上墙导轨之前，必须再次查阅有关器械的安装说明和安装插图。
- 由医院承担安装过程中的风险责任，顾问和/或建筑承包商负责判定医院墙壁安装设备的安全性，包括选择合适的紧固件以及合适的安装方式。在整个或部分拆除新建或改建的墙壁材料工作中，必须是出于装配上墙导轨的目的来定位16Gauge（约1.5mm）厚钢板或尺寸为2X6"（50.8X152.4毫米）的1#花旗松。以下仅作为指南信息提供。
- 不能替换或遗漏紧固件。
- 不要将支架或相关的零件安置于病人的上方。
- 可对导轨中线的两侧任何一边进行清理，例如床头灯，窗帘，邻墙或邻柱，门的旋转圆弧等。选择导轨位置时，需要考虑到电源和指示灯插座的位置。避免与输氧机，真空出口管和排气口等干涉。
- 确保装备的重量未超过额定载荷值：  
OSHPD 预先核准：M系列60磅（27千克）的机械手臂；未经OSHPD 预先核准的：VHM 40磅（18千克）的机械手臂，其最大额定载荷值超过60磅（27千克）。
- 虽然已在指南中尽最大努力确保导轨安装的安全性，但实际的建筑材料和安装过程是在GCX或迈瑞公司掌控之外的。所以GCX或迈瑞公司对任何此类安装失败不承担任何责任。

**OSHPD:** GCX 已向美国全州健康计划与发展办公室（OSHPD）证实其地震区导轨符合地震区预先批准的有关要求。为了被授予两个不同的 OSHPD 预先核准的锚固法（OPA），已动态测试过地震区导轨以及相关的紧固件。

**OPA-0079:** 预先核准的 GCX 19 寸地震区导轨包含了用于墙面和墙内结构的设计和配置。在这些预先核准的安装说明中已详细描述了四种不同的设计（A, B, C, D）。墙内结构设计必须由建筑记录工程师（SEOR）进行验证，且由足够详细的预先核准的要求来判定。

**OPA-0697:** 预先核准的 GCX 19" 地震导轨包含了用于墙面导轨的锚固，但并未包含用于墙内结构设计和配置的导轨锚固。建筑记录工程师（SEOR）必须提供所有墙内结构的详细信息，除了预先核准的额定值外，这些信息都已被设计或验证可满足支撑重量以及支撑所需的力度。

#### 定位上墙导轨

设备和上墙支架可能还要求考虑导轨的安置位置（指南未涉及相关内容）。在安装上墙导轨前，需考虑设备的操作使用，人体工程学要求，以及支架活动范围。

设备：对于 19 寸（48.2 厘米）的上墙导轨，安装时底边离地面 54 寸±4 寸（142.2 厘米）。



# 支撑衬垫的方法

## 方法 A

### 地震区

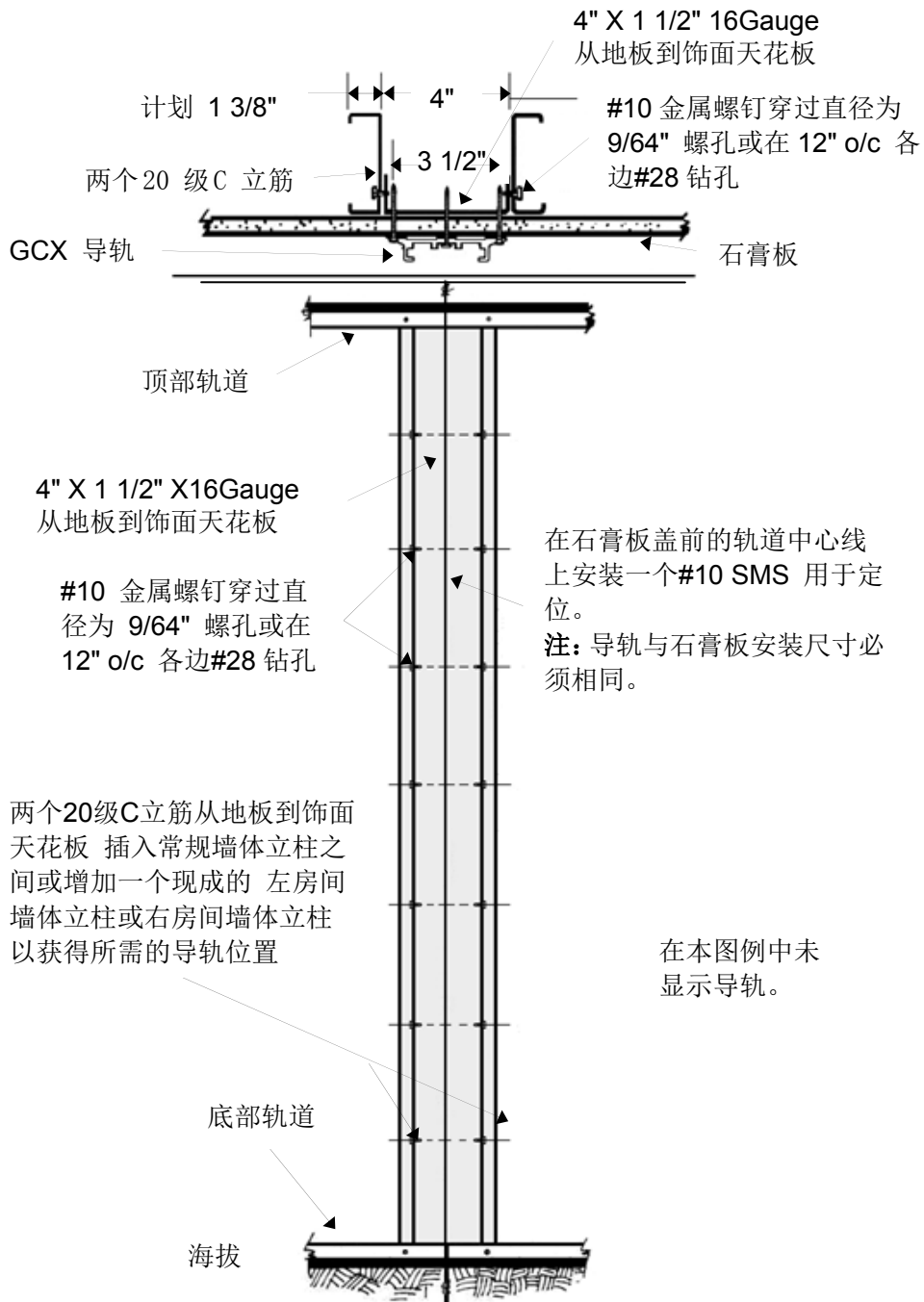



# 支撑衬垫的方法

## 方法 B

### 地震区

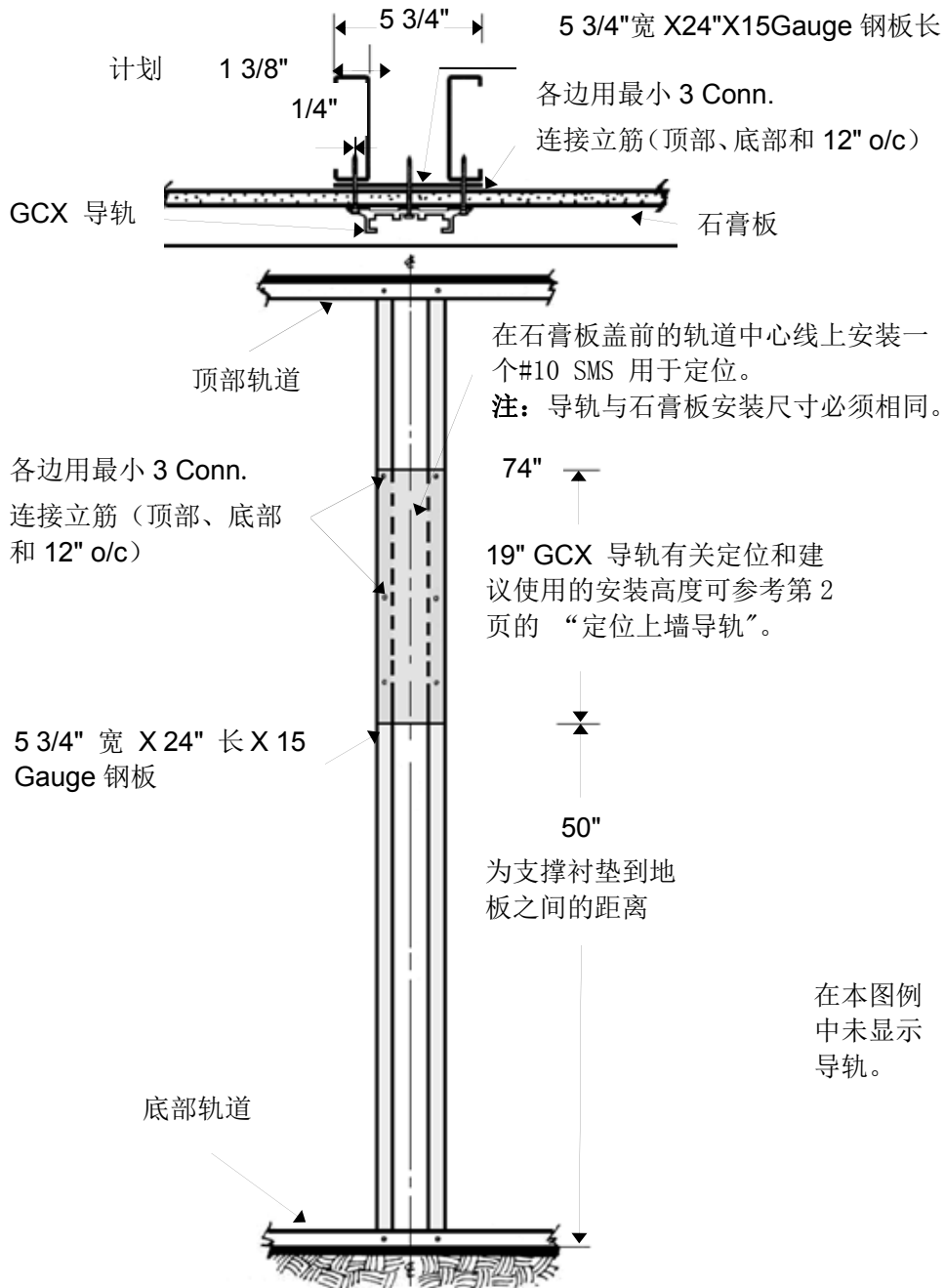

# 支撑衬垫的方法

## 方法 C

### 地震区

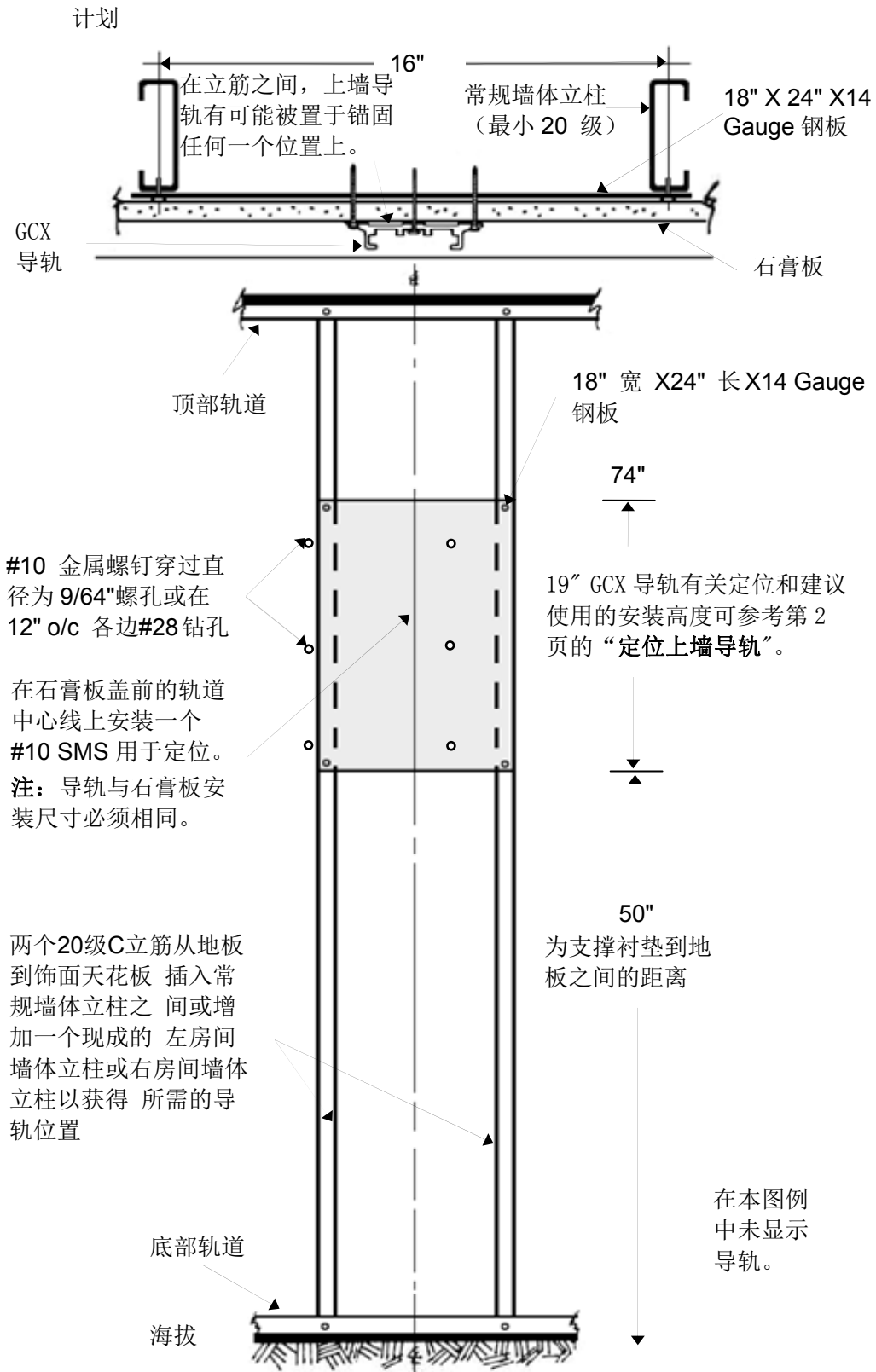

# 支撑衬垫的方法

## 方法 D

### 地震区

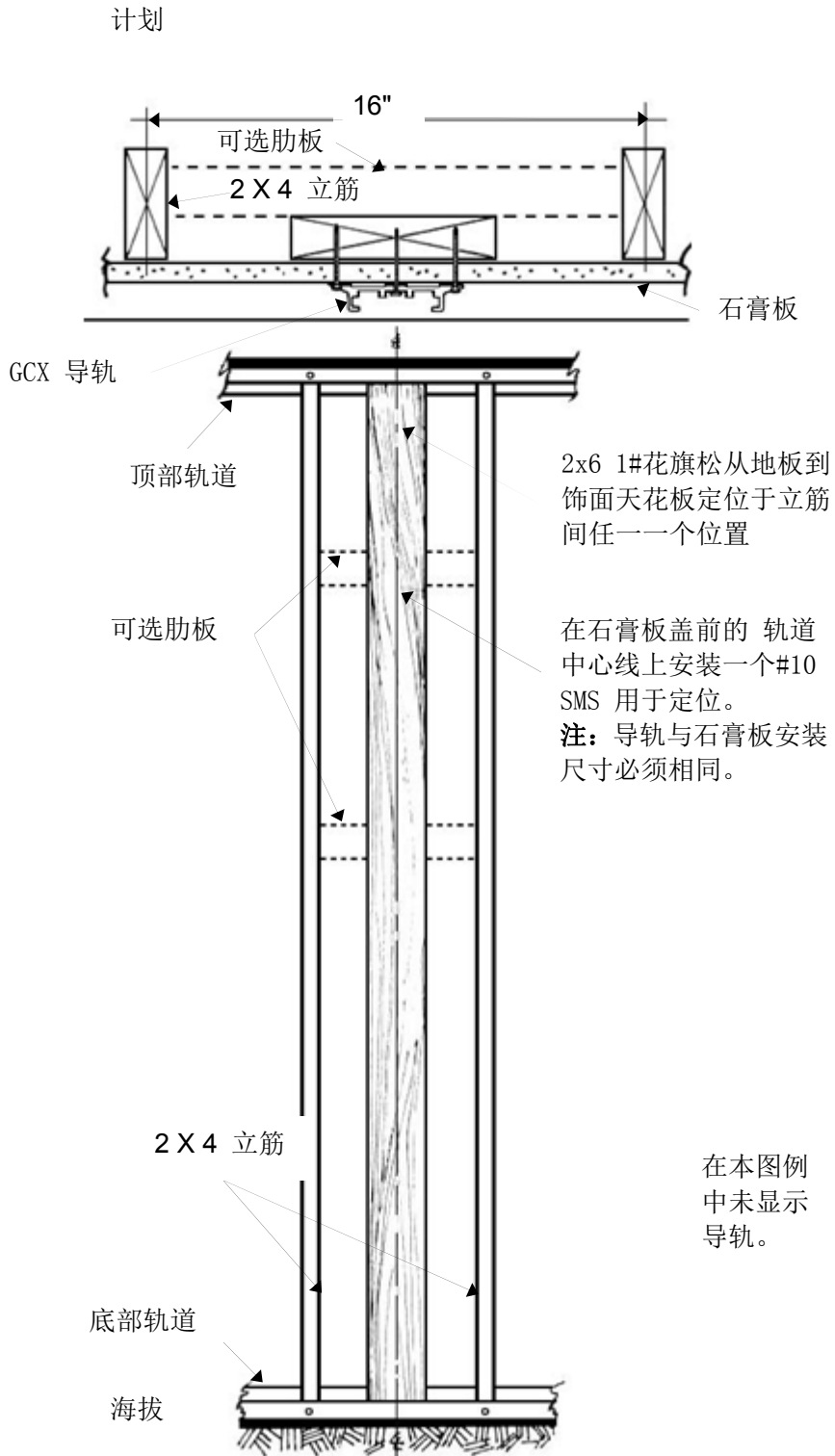

## ■ 标准上墙导轨

以下上墙导轨零件参考图表列出了 19"标准上墙导轨的零件总数。可提供更长的上墙导轨和额外的零件来补充额外安装点的需求。

### 标准上墙导轨零件参考

序列号#	描述	数量
1	#12 x 2 3/4" 金属螺钉 (SMS)	4
2	1/4-20 x 3" 盘头机械螺钉(PHMS) w/兰花夹	4
3	固定导轨止动销	1
4	10-32 x 3/8" 平头机械螺钉(FHMS)	1
5	可压低的导轨止动销	1
6	标准上墙导轨	1



### 安装标准上墙导轨

#12 X 2-3/4" 高强度菲利普头螺钉需要钻直径大小为 11/64" (17 毫米) 的螺孔。插入顶部螺钉并对准导轨，然后做好标记，最后给其它螺钉钻孔。须使用球形手柄螺丝刀或不超过 60 寸/磅的扭矩限制机械螺丝刀来起头和钉旋螺钉。螺钉必须穿过导轨、石墙且完全与木立筋或 16Gauge (约 1.5mm) 厚钢板衔接。

使用兰花夹给 1/4-20 x 3"盘头机械螺钉钻直径大小为 3/4" (19.5 毫米) 的螺孔。当墙体钢板厚度薄于 16Gauge (约 1.5mm) 厚钢板时，必须使用 兰花夹。

**安装注意事项：**当 OSHPD 的核准未做要求时，地震区上墙导轨可以像安装标准上墙导轨一样进行安装。

### 导轨安置建议

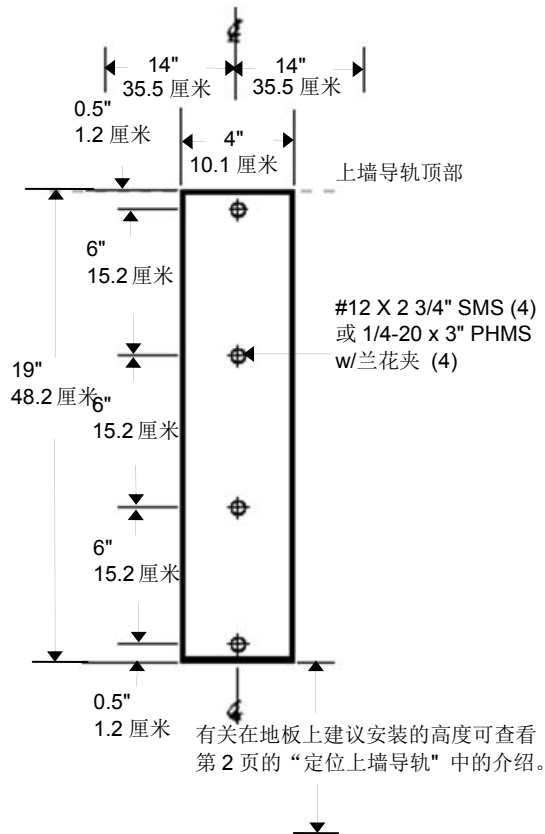

### 零件安置

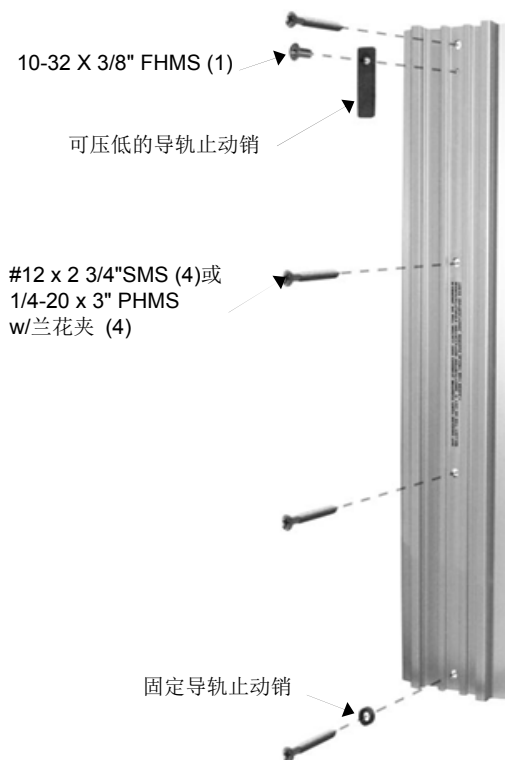

## 方法 A 标准

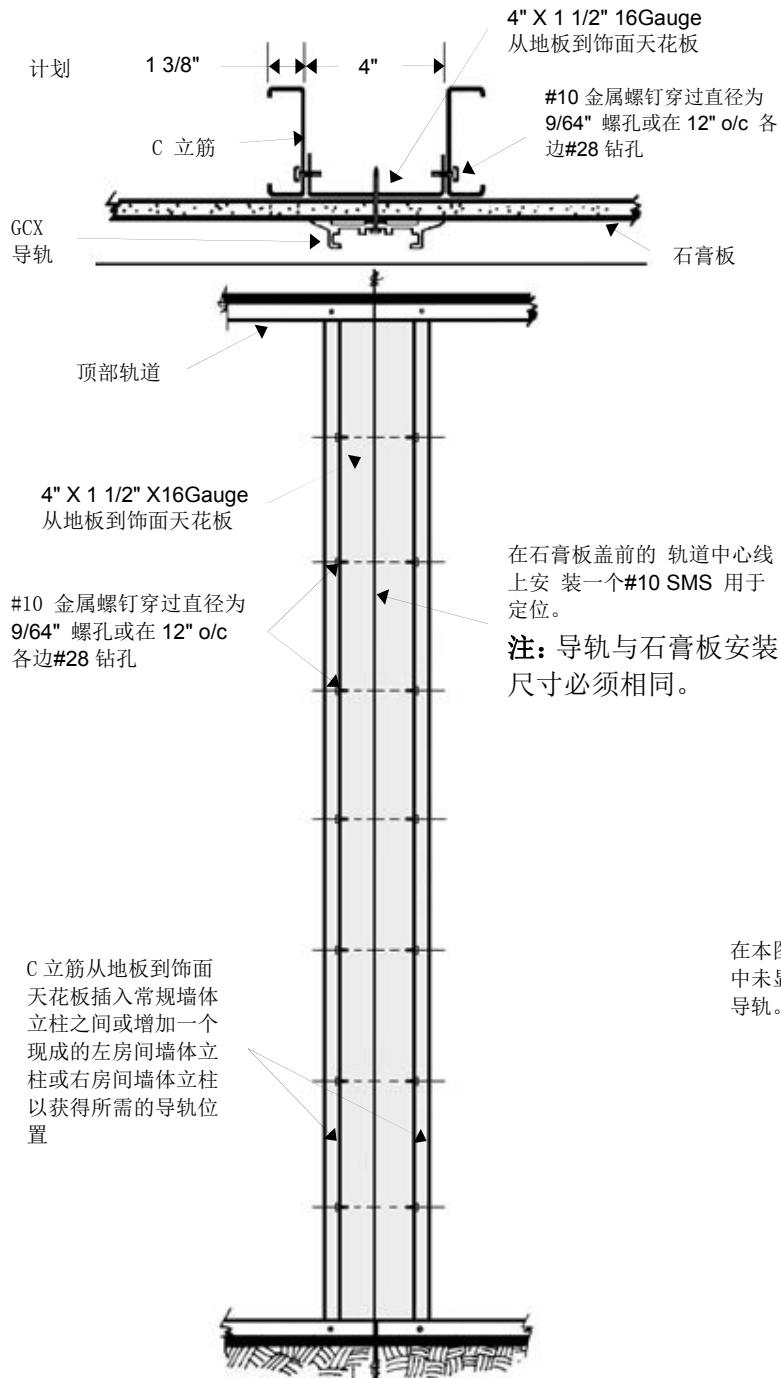

该锚固可以快速、简单的安装标准上墙导轨。16Gauge 钢板可防止材料挤压螺杆柄(削裂)。直径大小为 11/64" 的螺孔需要#12X2-3/4"高强度菲利普头螺钉(4)，将其安装在中心线下。(非地震区使用)。

第二轨道可用于背对背的安装。如果当地建筑法规允许的话，可能会用到 2" X 4"木立筋。

### 16Gauge (约 1.5mm) 厚钢板或木立筋上方的石墙 (石膏板):

给立筋中心线进行精准定位。敲入一个#4 饰面钉并穿过石墙钉入立筋。取出螺钉并再在左右各 3/8" (9.5 毫米) 的位置钉入螺钉直到找出立筋边缘的位置并由此判定中心线。上墙导轨的 4 寸 (10.2 厘米) 宽边将覆盖掉这些勘探孔。

在穿过导轨中心线的一个 16Gauge 钢板上给#12 X 24-3/4" 高强度菲利普头螺钉钻直径大小为 11/64" (17 毫米) 的螺孔。安装顶端螺钉并对准导轨, 然后做好标记, 最后给其它螺钉钻孔。

### 薄于 16Gauge (约 1.5mm) 厚钢板并位于钢板上方的石墙 (石膏板):

按照上述的操作说明, 定位立筋的中心线。使用 1/4-20 X 3" 盘头机械螺钉和兰花夹。用锋利快速的钻头或螺旋钻头 (要求为定位孔) 给直径大小为 3/4" (19.5 毫米) 的螺孔钻孔。注意位于导轨底部圆形的止动销有穿过底部螺钉的螺柄。插入螺钉并穿过上墙导轨螺孔, 然后将兰花夹固定在螺钉上。把兰花夹插入之前的钻孔中。用水准仪确保导轨是垂直于螺钉最终位置前的。

### 钢立柱上的钢板网抹灰层, 空心砖, 空心块:

给大小为 3/4" (19.5 毫米) 的螺孔钻孔。在坚硬的材质上打孔, 使兰花夹可以穿过。插入螺钉并穿过上墙导轨, 然后将兰花夹固定在螺钉上。把兰花夹插入之前的钻孔中。用水准仪确保导轨是垂直于螺钉最终位置前的。

### 混凝土墙/水泥墙

对于水泥墙, 通过利用 6 颗 I 型 M6X65 的膨胀螺栓进行固定:

1. 根据超声机器需要固定的高度来确定墙面的导轨安装孔位置, 在墙面垂直方向打两排 (每排 3 个) 直径  $\Phi 8\text{mm}$ 、深度 40mm 的圆孔, 圆孔相邻尺寸如下图所示:

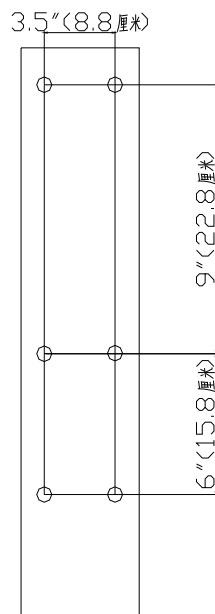

2. 将支架导轨上六个  $\Phi 7\text{mm}$  的孔对准墙面上的圆孔, 然后用 6 个 M6X65 的膨胀螺钉固定, 如下图所示:

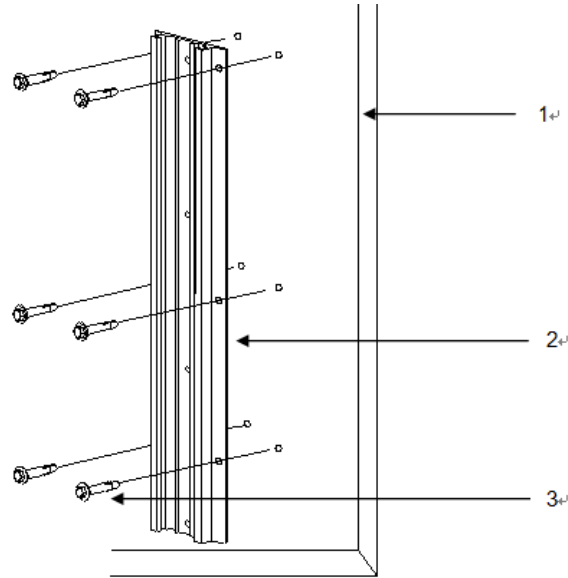

1. 墙体； 2-支架导轨； 3-膨胀螺钉（M6X65）

**穿墙，背对背安装：**

必须先取得足够长的 1/4-20 机械螺钉，螺帽，垫圈和/或后板，通过持续钻孔并打穿薄隔墙来安装导轨。这个过程中建议使用 Portalign 钻头卡具。

**特殊应用：**

导轨可装配在 GCX 4 X 4"（10.2 x 10.2 厘米），1/8"（3.2 毫米）的幕墙铝材支承柱或某些竖框等。指南中未介绍到任何情况，请联系 GCX 或迈瑞来讨论问题的解决办法。

## 2.1.2 吊塔导轨

38mm 立柱锁 7"/17.8cm 轨道

此节将:

- 详述将轨道绑至 38mm 立柱上。



**警告:** 确保所安装的支架和设备重量不超过 60Ibs (27.2 Kg)。



### 部件详情

安装包中包含以下部件:

物品	详情	数量
1	夹块	2
2	轨道	1
3	10-32 x 5/8" 内六角圆柱头螺丝 (SHCS)	1
4	5/32" 六角扳手	1

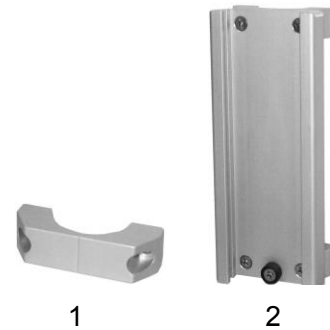

所需工具: 5/32" 六角扳手 (提供)

### 固定支架至圆柱

使用 5/32" 六角扳手 (提供), 用 2 块夹块和 4 枚 10-32 x 5/8" 内六角螺丝 (SHCS), 将轨道固定至 38mm 立柱上。

平稳旋紧螺丝 (40 in/lb, 最小) 至夹块固定。

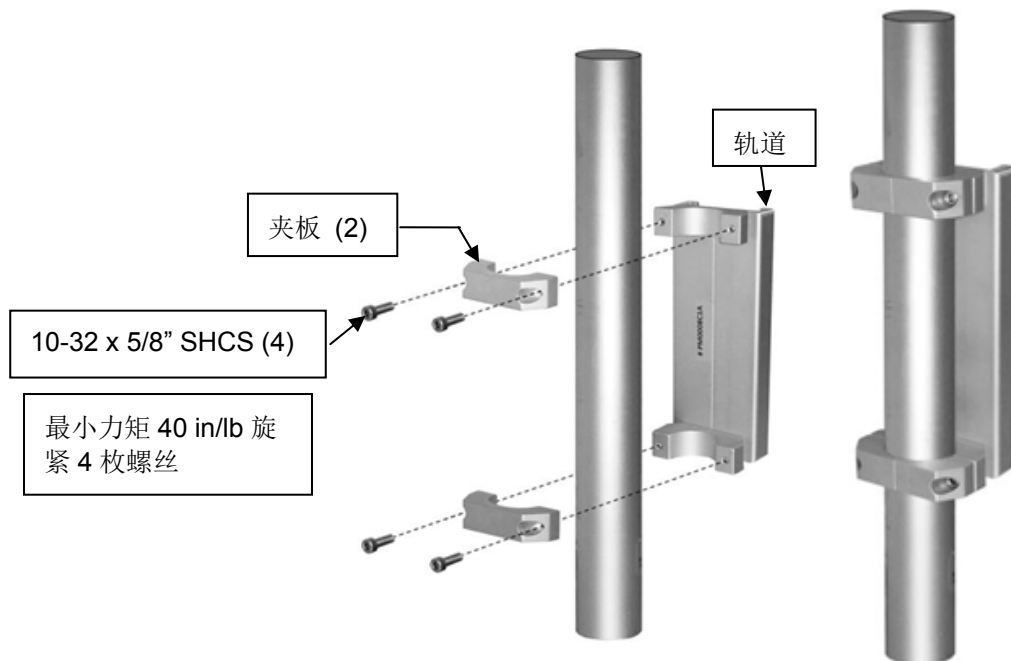



## 2.2 支撑臂



此章节旨在描述 VHM™ 系列支撑臂的安装，操作以及调节步骤。安装或使用产品前，请阅读此章节和所有设备相关安装材料。

## 2.2.1 安装，操作和维护警告信息

关于 VHM 支撑臂的安装，操作及维护，该章节包含以下警告信息。安装，操作及维护 VHM 支撑臂之前，请完整阅读该章节。未能遵循以下警告信息可能导致设备或人员损伤。

### 安全警告信息

- 请勿将 VHM 支撑臂或支架设备置于病人之上。需注意，VHM 支撑臂可大幅上下或左右移动。支架设备和支架组件靠近设备，医护人员或病人时，需谨慎。GCX（迈瑞）建议在安装和使用支撑臂之前，医院风险管理人員需验证设备的适用性。
- 如果 VHM 支撑臂为墙面安装，确保已安装轨道并使之与轨道安装指南相符。
- 确保所安装支架设备重量不超过 VHM 支撑臂额定负荷。检查支撑臂底部表面“最大承重”标贴（标贴位置查看 2.2.2.1 章）。
- 从 VHM 支撑臂上拆除支架设备时，高度调节锁或旋钮必须处于锁定状态。
- 打开高度调节锁时，立于 VHM 支撑臂和支架设备一侧，小心操作。高度调节锁锁定时，由于附加物或移除设备（非主要部件），总安装负重可能会有所变化。高度调节锁打开时，总负重的改变可能会引起支撑臂突然向上或向下移动。



- 由于正常的磨损或因不恰当的调节倾斜或旋转功能，或因气弹簧寿命终止，支架设备或支撑臂有可能突然发生移动。（参阅 2.2.4 章、2.2.5.2 章、2.2.5.5 章）。每年至少需检查和调节 VHM 支撑臂两次。检查应包含以下步骤：
  - 1) 安装设备，打开高度调节锁，在整个垂直滑轨范围内移动支撑臂。支撑臂每移动一处，负重都应保持其位置。如有必要，根据第 2.2.4 章可调节平衡装置。
  - 2) 紧抓支架设备，从左向右进行旋转。设备旋转时有一定张力或阻力，而非松动旋转。如有必要，根据 2.2.5.5 章可调节旋转张力。
  - 3) 紧抓支架设备，以轴为中心，在轨道装置中，从左向右进行旋转。设备在已轴为中心旋转时有一定张力或阻力，而非松动旋转。如有必要，根据 2.2.5.4 章可调节轴旋转张力。
  - 4) 紧抓支架设备，在整个活动范围内，前后倾斜，为防止在使用过程中设备突然前倾，倾斜装置应具有一定的张力和阻力。
  - 5) 检查螺帽是否松动。为方便操作及安全起见，旋紧螺丝螺帽。
  - 6) 由于存在人员损伤或设备损坏的风险，非 GCX 人员不可拆除 VHM 支撑臂外壳。未遵守该项，则不在保修范围之列。

未能定期按说明检查或调节支撑臂，可能会造成设备损坏或人员损伤。如未打算对支撑臂进行定期检查，请全部拆除，避免支撑臂不必要的移动。如正常进行定期检查，VHM 支撑臂可工作 5 至 10 年。如果支撑臂不可调节或未能进行维修服务，请联系 GCX 或 Mindray 用服工程师。

## 2.2.2 轨道内安装 VHM 支撑臂

2.2.2.1 如果提供，在支撑臂右侧，顺时针将高度调节杆穿入安装孔中（下图左侧）。顺时针锁定调节杆，逆时针打开调节杆。安装注意事项：**VHM 支撑臂与负重完全平衡时**，除非用户移动，支撑臂将处于预定垂直位置。在滑轨内改变支撑臂位置，需锁定高度调节杆。锁定高度调节杆可避免支撑臂上下移动。参阅 2.2.4 章（《调节平衡力》）或 2.2.5.2 章（《调节安装设备高度》）查看高度调节杆使用详情。

带有弹簧锁的 VHM 支撑臂出厂时已配有锁定旋钮。



### 弹簧锁型 VHM 支撑臂

此类 VHM 支撑臂与移动显示器配合使用。出厂时已安装锁定旋钮。安装支撑臂至轨道之前，确保锁定旋钮处于锁定位置。

**安装注意事项：**为了使锁定功能正常使用，调节支撑臂使之与安装设备重量平衡（参阅 2.2.3）。

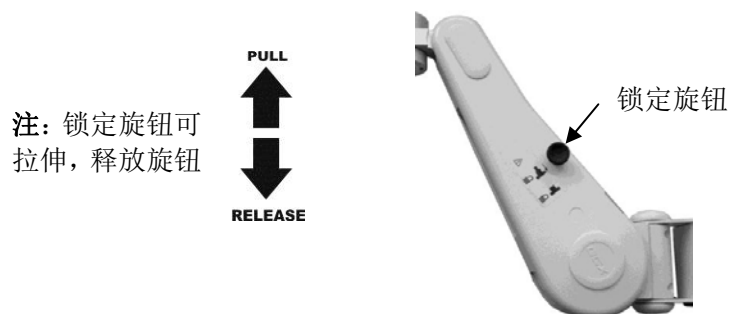

**2.2.2.2** 托住支撑臂下部，将滑条放至轨道上方（左下），并将支撑臂推入指定位置。

**2.2.2.3** 使用提供的 1/8"六角扳手，旋紧滑条上 4 枚固定螺丝，固定支撑臂位置（右下）。



## 2.2.3 安装设备到 VHM 支撑臂

大多数设备需要一个特殊设备支架适配器的附加物，而这个附加物将由 GCX 提供或由供应商提供。根据适配器中的安装指南（第 2.3 章），安装支架适配器。

### 2.2.3.1 安装支架

最大承重重量:9.0kg。

拆装工具：十字螺丝刀

1. 将主机支架转接板上的螺钉孔与支撑臂上的螺纹孔对齐。
2. 拧紧（3）10-32 x 3/4" 十字槽沉头螺钉（FHMS）。



3. 将主机支架上的螺钉孔与主机支架转接板的螺纹孔对齐。
4. 拧紧 (3) 10-32 x 1/2" 十字槽沉头螺钉 (FHMS)。

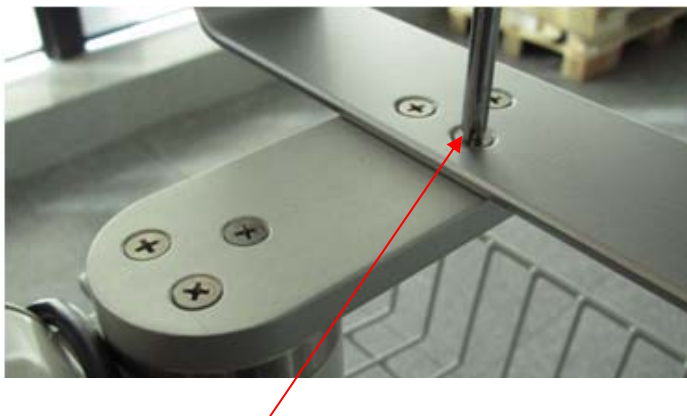

(3) 10-32 x 1/2" 十字槽沉头螺钉 (FHMS)

### 2.2.3.2 安装主机



**警告：** 装配主机前必须保证支撑臂被锁紧。

1. 沿箭头方向（从上之下）将支架凸缘扣入到安装槽中。



支架凸缘

2. 沿箭头方向轻推主机，直至弹簧销卡进主机下端的限位槽中。  
**注意：** 若此过程出现异常，或弹簧销未卡紧限位槽，请向下拉拔弹簧销后再轻推主机。  
安装完成后，反向轻拉主机判断主机是否被成功卡紧。



## 2.2.4 调节平衡力



**警告：** 请勿随意调节平衡力，除非设备或附件都已安装至支撑臂。执行以下步骤时，请谨慎操作。

在支撑臂垂直活动范围之内，调节VHM使之与安装设备平衡。在关闭高度调节杆或锁定旋钮的情况下，VHM支撑臂保持适当高度。因设备重量不同，根据实际情况，调节性能至最佳。

所提供的 A 1/2" [13mm]直筒扳手用于紧急调节。

### 调节平衡力：

1. 紧抓支架设备后部支撑臂，将支撑臂放至水平位置，可见调整器外壳（左下）。将支撑臂锁定至水平位置。
2. 打开调整器外壳，从外壳后部槽口处伸入一字螺丝刀，并向上撬起。如有必要，打开并重新调节支撑臂，直到平衡力调整器螺栓可从调整器外壳中取出（下方中图）。平衡力调整器可见后，锁定支撑臂。
3. 使用 1/2" [13mm]直筒扳手放于调整器之上，打开支撑臂。顺时针旋转调整器增加平衡力，或者逆时针旋转减小平衡力。正确调节平衡力，轻微用力，支架设备便可上下移动，松开支撑臂后，支架设备也不会抬升或跌落。

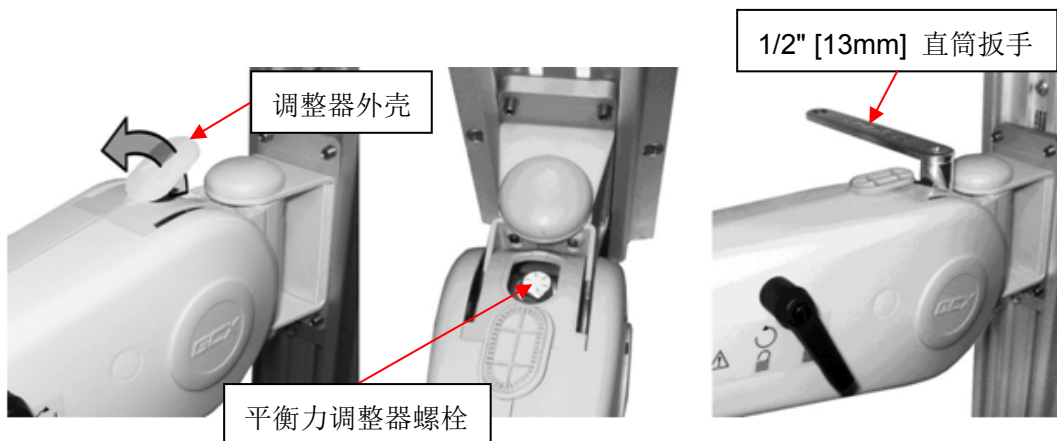

4. 关闭调整器外壳。

## 2.2.5 操作和调节 VHM 支撑臂

关于张力，检查枢轴，倾斜以及前方旋转装置。参阅对应章节并遵守调节步骤。

### 2.2.5.1 平衡力调节-参阅 2.2.4 章

### 2.2.5.2 调节安装设备高度



**警告：**

- 设备未安装至支撑臂时，请勿调节高度。
- 打开高度调节锁时，立于 VHM 支撑臂和支架设备一侧，小心操作。高度调节杆锁定时，由于附加物或移除设备（非主要部件），总安装负重可能会有所变化。高度调节杆打开时，总负重的改变可能会引起支撑臂突然向上或向下移动。



紧握支架设备两侧（或把手），将其移动至预定位置。支撑臂调节恰当后，支撑臂会保持在调节后的新位置高度。

**注：**在支架设备垂直调节时，需打开/关闭高度调节杆（参阅以上警告信息）。在正常调节平衡力时，无需打开高度调节杆。

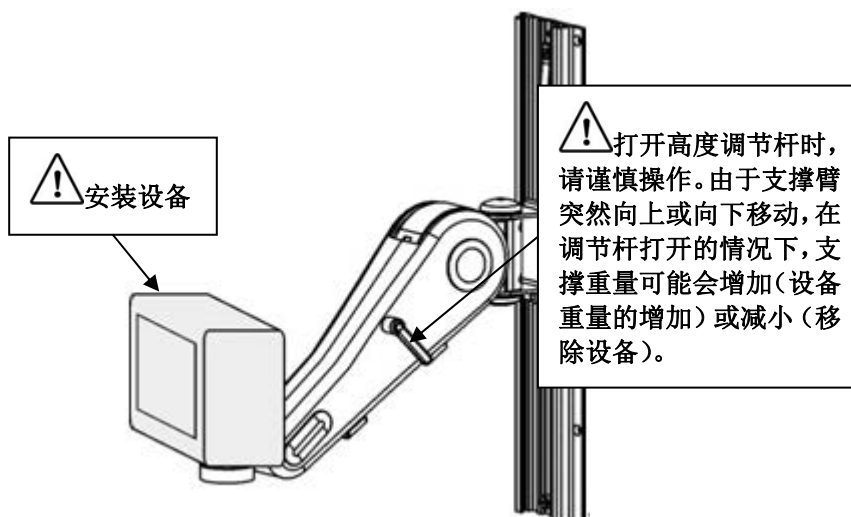



### 2.2.5.3 安装支撑臂至轨道

 **注意：** 支撑臂安装至设备上时，请勿从轨道中拆除支撑臂。

1. 使用高度调节杆或锁定旋钮，在最高垂直位置处，固定支撑臂。
2. 使用提供的 1/8"六角扳手，拆除滑轨上的 4 枚固定螺丝。
3. 靠近设备，移除支撑臂下部，减轻支架设备的重量。同时，在滑轨前方，向上或向下拉支撑臂末端。
4. 旋紧 4 枚固定螺丝。

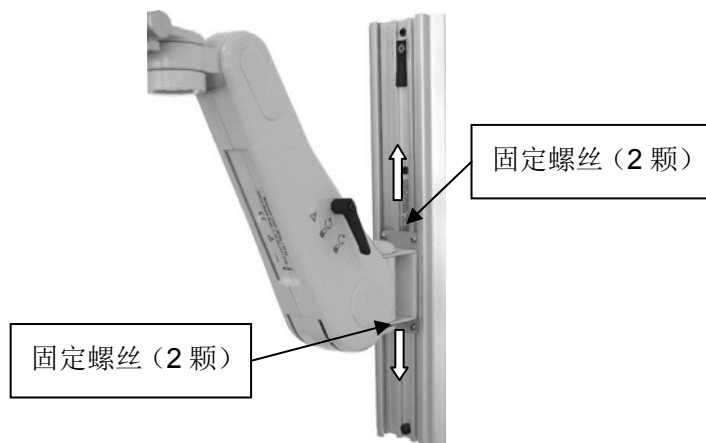

### 2.2.5.4 枢轴 VHM 支撑臂并调节枢轴张力

1. 在轨道中旋转支撑臂，只需推动支撑臂。
2. 从枢轴螺栓处拆除较高位置和较低位置的螺母，以便调节枢轴张力。  
使用提供的 1/2" [13mm]套筒扳手和 1/2" [13mm]梅花扳手/开口扳手，根据所需力度，旋紧或松开枢轴螺栓和六角螺母。  
将螺母重新装回枢轴螺栓各端。

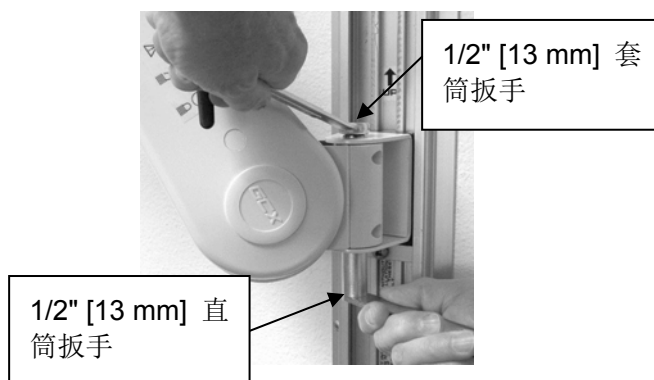



### 2.2.5.5 旋转支架设备并调节旋转张力

1. 推拉设备旋转支架设备。
2. 使用提供的 1/2" [13 mm]套筒扳手，旋紧或松开旋转紧固螺母，调节旋转张力。

**安装注意事项：**如有必要，从旋转杯窝中拆除下部立杆，可见旋转紧固螺母。



**警告：**旋转紧固螺母的最小扭矩为 20 in- lbs [2.3 N-m]。

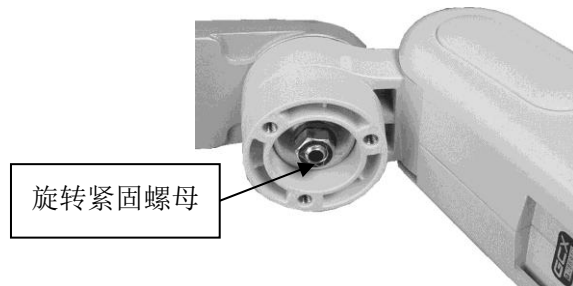

### 2.2.6 线缆管理

线缆导向装置为支撑臂下方线缆走向提供方便。将线缆导向装置插入支撑臂下方的凹槽中，并将其卡紧。支撑臂前部和后部线缆保持放松，以免线缆打结，连接器受损或线缆引导装置受损。

引导装置插入伸缩支撑臂下方凹槽中。

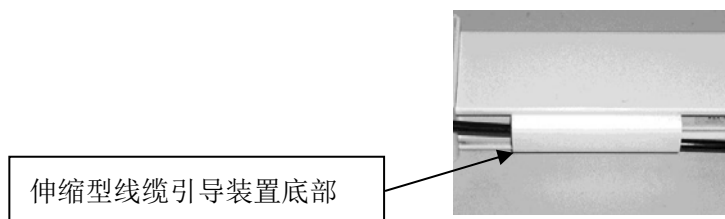

### 2.2.7 日常维护

定期检查支架系统相关的所有倾斜，旋转，枢轴以及支架硬件。为方便操作及安全起见，根据所需调紧或调节。

## 2.2.8 清洁支架组件

1. 可使用适用于医院环境中的温和、无腐蚀性的溶剂清洁支架组件（例如，稀释的漂白剂，氨水或者酒精溶剂）。
2. 强化学试剂如丙酮，三氯乙烯会对表层造成永久性损伤。
3. 请勿使用钢丝球或其他腐蚀性物质。
4. 由使用未经许可的物质或工艺引起的损伤将不在保修范围之列。建议在支撑臂上不明显区域，小范围内测试清洁剂和表层兼容性。
5. 请勿浸泡支撑臂或使液体流入支撑臂。使用润湿的布擦除任何清洁剂。清洁后完全擦干支撑臂。

**注意：**作为控制感染方法之一，对所列举的化学试剂或工艺的效能，GCX 或迈瑞公司不负有责任。请咨询医院感染控制专人或流行病医师。

## 2.2.9 VHM 支撑臂故障排除

症状	可能诱因	解决方案
支架设备未处于水平位置或与地面不平行。	轨道未垂直。检查水平位置。	调整轨道至垂直，或重新安装轨道。
	设备重量与支撑臂额定负荷未能抵消。	安装设备至匹配的额定负荷支撑臂上。
	旋转硬件松动	调节旋转螺母（2.2.5.5 章）。
	枢轴硬件松动	调节枢轴螺栓（2.2.5.4 章）。
	支架表面不稳固（例如，墙面，麻醉剂侧面，等等）（未能握紧支架硬件）。	加固支架表面或重新放置轨道。
	支架表面轨道松动。	检查使其垂直，旋紧或重新（重新安装）放置轨道。
	滑轨中 4 枚固定螺丝松动。	重现放置支撑臂并旋紧螺丝。
支撑臂打开时，设备缓慢上升或下滑	支撑臂与设备重量未达到平衡。	调节平衡力。参阅 2.2.4 章。
	支架设备重量（负重）与支撑臂额定负荷未能抵消。	使用匹配的额定负荷的支撑臂，调节平衡力。参阅 2.2.5 章。
支撑臂枢轴移动幅度过大	枢轴螺母松动。	调节枢轴螺栓（2.2.5.4 章）。
支撑臂无法转动。	枢轴螺母太紧。	
设备旋转幅度过大。	旋转螺母松动。	调节旋转螺母（2.2.5.5 章）。
设备无法转动。	旋转螺母太紧。	
设备无法倾斜。	倾斜调节杆太紧。	调节倾斜度或倾斜张力。参阅 2.2.5.6 章。
	多余倾斜张力。	
设备无法保持倾斜位置。	倾斜调节杆松动。	
	倾斜张力不足。	
支撑臂打开时，无法上下移动。	支撑臂与支架设备重量未达到平衡。	调节平衡力。参阅 2.2.4 章。
支撑臂从导轨突然滑落。	滑轨中 4 枚固定螺丝松动。	重新放置支撑臂并旋紧固定螺丝。
锁定旋钮（弹簧锁支撑臂）无法拔出（打开）。	支撑臂与支架设备重量未达到平衡。	调节平衡力。参阅 2.2.4 章。
	支架设备重量（负重）与支撑臂额定负荷未能抵消。	
平衡力螺栓无法调节。	支撑臂为锁定在水平位置。	重新放置支撑臂，并将支撑臂锁定于水平位置。

## 2.3 适配器固定架

此节将详述普通电源的墙面支架。

最小电源尺寸可使用 12" [30.5 cm]钩带	最大电源尺寸可使用 18" [45.7cm]钩带
1.4" [3.56 cm] x 2.3" [5.84 cm] or 7.4" [18.8 cm] 周长	4.0" [10.16 cm] x 4.0" [10.16 cm] or 16" [40.6 cm] 周长

### 部件详情

安装包中包含以下部件和硬件（查看如下所示的部件图片，硬件图片此处未显示）：

物品	详情	数量
1	电源支架（使用 12"钩带）	1
2	线护圈，尼龙	1
3	#8-32 x 3/8"盘头螺丝（PHMS）	1
4	#8 平垫圈	1
5	钩带，18'	2



所需工具：1/8" 六角扳手（提供）十字螺丝起子（不提供）。

最大承重重量：1.5kg。

### 安装电源支架至轨道中

1. 将电源支架滑动部分插入 GCX 轨道中，放入预定位置。

**安装注意事项：**根据实际情况，支架可水平或垂直放置，如下图所示。

2. 使用 1/8" 六角扳手，旋紧1/4-20 固定螺丝，将电源支架固定至轨道中。

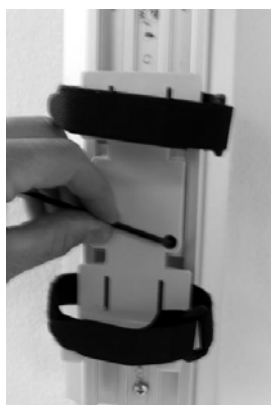

垂直方向

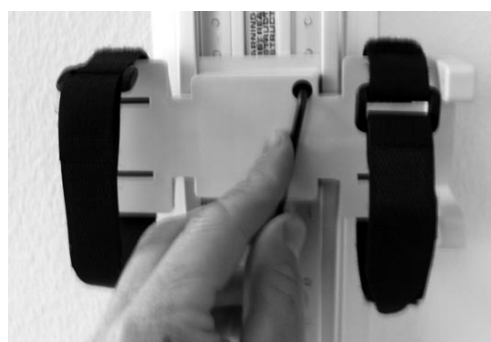

水平方向

### 电源放入支架中

1. 将电源放入支架中，通过钩环插入钩带，拉紧，并按紧钩带（如下左图所示）。

**安装注意事项：**支架已由两条 12"钩带提前组装完毕，这些钩带可基本固定电源，但是对于较大电源可使用 18"钩带（提供）来固定。

2. 通过尼龙线护圈缠绕电线，用一枚#8-32 x 3/8"和#8 平垫圈（下右图）将护圈固定至支架底部。



系紧魔术扣



使用固定器固定电线



安装完毕的电源支架

### 日常维护

定期检查支架系统相关的所有硬件。为方便操作及安全起见，根据所需调紧或调节。

### 清洁支架组件

1. 可使用用于医院环境中的温和，无腐蚀性的溶剂清洁支架组件（例如，稀释漂白剂，氨水或者酒精溶剂）。
2. 强化学试剂如丙酮，三氯乙烯会对表层造成永久性损伤。
3. 请勿使用钢丝球或其他腐蚀性材料清洁支架组件。
4. 由未经许可的物质或工艺引起的损伤将不在保修范围之列。在不影响兼容性的情况下，建议在支撑臂上小范围内测试清洁剂。
5. 请勿浸泡支撑臂或使液体流入支撑臂。使用润湿的布擦除任何清洁剂。清洁后完全晾干支撑臂。

**注意：**作为控制感染方法之一，对所列举的化学试剂或工艺的效能，GCX 或迈瑞公司不负有责任。请咨询医院感染控制专人或流行病医师。

## 2.4 储物篮

最大承重重量:2.0kg。

拆装工具: 十字螺丝刀

1. 将储物篮上的螺钉孔与转接板上的螺纹孔对齐。
2. 用十字螺丝刀拧紧 (4) 10-32 x 3/8" 十字槽平圆头螺钉 (PHMS), 将储物篮固定到转接板。

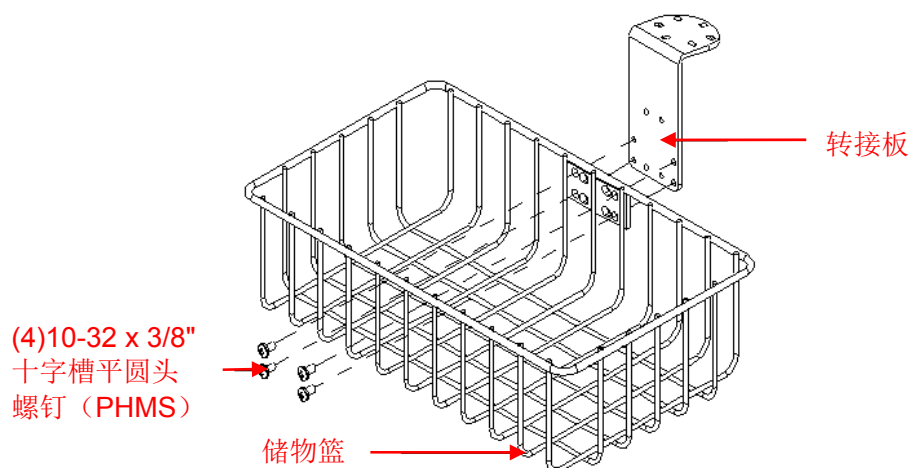

3. 将转接板上的螺钉孔与回转接头上的螺纹孔对齐。
4. 用 5/32 (4 毫米) 六角扳手拧紧 (3) 10-32 x 3/8" 内六角圆柱头螺钉 (SHCS)。

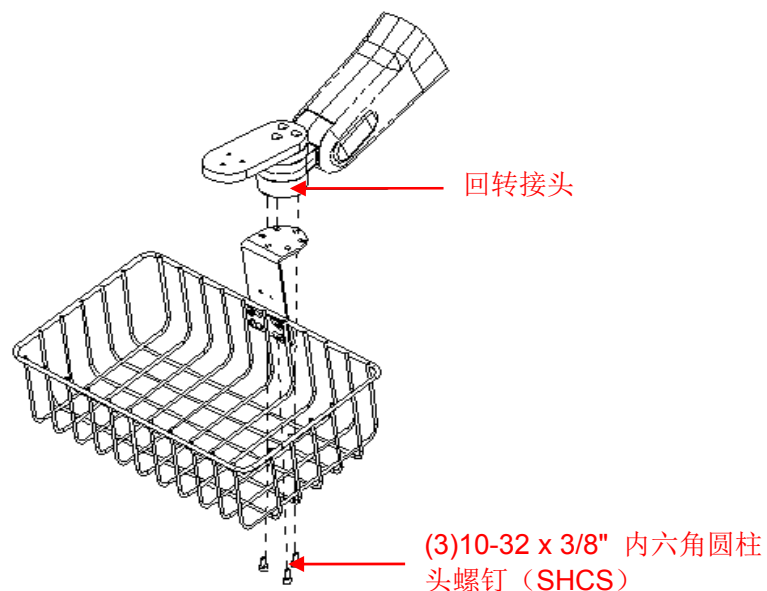

# 3 机械安全检查

此节主要针对超声设备关键部件的机械强度和机械功能进行机械安全检查。

检查评估方式主要为：目测和操作检查。

如果不能通过检查结果，系统可能处于异常状态，必须停止使用机器并采取适当措施。

检查流程如下：

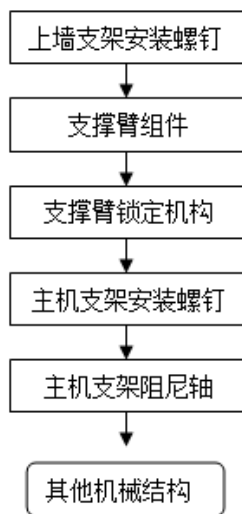

机械安全检查流程图

机械安全检查列表：

内容	方法	工具
上墙支架安装螺钉	a)目测检查：确认支架安装板没有出现翘曲。 b)用扳手检查：确认安装螺钉没有松动。	内六角扳手（自带）
支撑臂组件	a)双手垂直方向摆动支撑臂，能够垂直转动到规格角度，且灵活自如，无异常声响。 b)双手水平方向推动支撑臂，能够水平转动到规格角度，且灵活自如，无异常声响。	无
支撑臂锁定结构	旋转支撑臂锁定扳手至 位置，支撑臂被锁定，不能上下摆动。	无
主机支架安装螺钉	用扳手检查：确认安装螺钉没有松动。	十字螺丝刀
主机支架阻尼轴	旋转主机支架主体至规定角度，主体能平稳固定。该过程中阻尼轴灵活自如，无异常声响和现象出现。	无
其它结构部件	确认其它结构件没有零件松脱、外壳开裂，无导电部分外露	无

# 1 Structure of Wall Mount

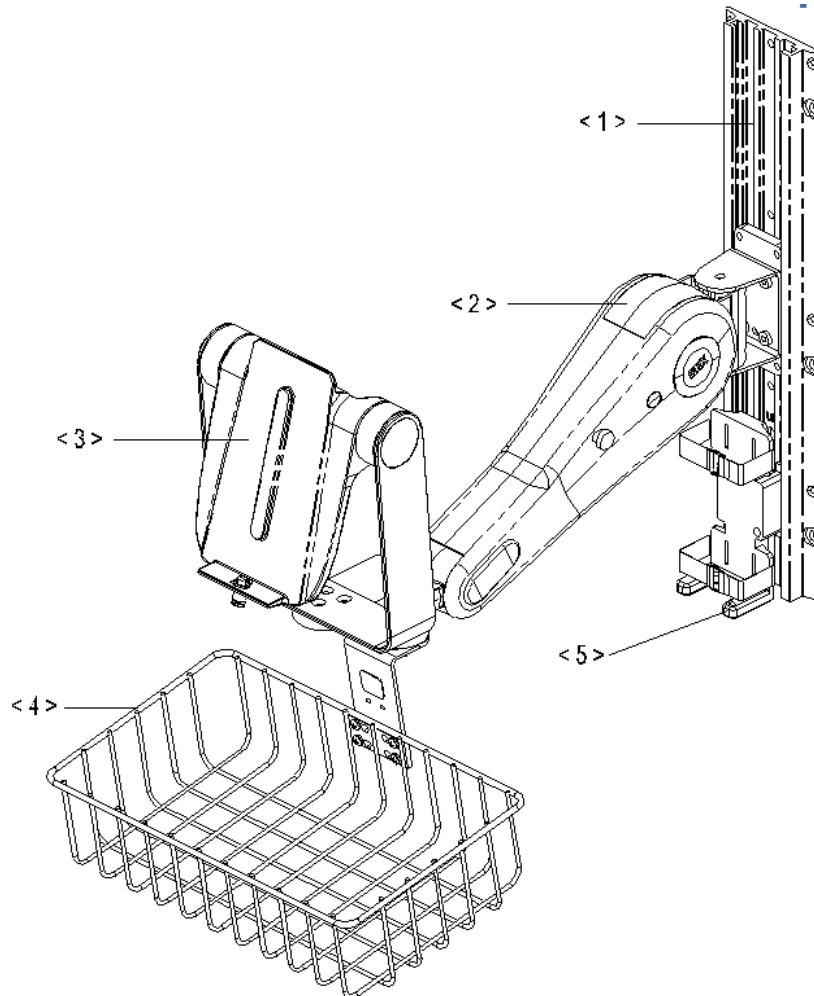

Item	Name	Function
1.	Wall Channel	Fix the wall mount to the wall. Note: replace the <i>wall mount channel</i> with <i>Adapter for connecting to the crane</i> . Fix the wall mount channel to the crane.
2.	Arm	Used for adjusting the angle of wall mount.
3.	Main unit support	Used for fixing the ultrasound main unit.
4.	Storage Basket	Used of keeping tissue, etc.
5.	Adapter bracket	Used for holding the external adapter.



# 2 Installation

---

## 2.1 Channel

### 2.1.1 Wall Channel



#### Warnings:

- Installations must be performed by Qualified Personnel. Failure to follow these Instructions may result in Serious Injury.
- Instructions and the Illustrations covering the specific Instrument to be mounted should be reviewed prior to Installation of Wall Channel.
- It shall be the responsibility of the hospital, its consultants and/or contractors to determine that the wall is adequate to safely mount instrumentation. This includes the selection of appropriate fasteners and the proper installation of the same. In new construction and remodeling work where the wall covering can be entirely or partly removed, a 16 gauge steel stud or a 2 X 6 Doug Fir #1 Stud should be located for the purpose of attaching the wall channel. The following is provided as guideline information only.
- Do not substitute or omit Fasteners.
- Do not position any Mounts or related hardware above a patient.
- Allow clearance on either side of the channel centerline to clear objects such as over-bed lighting, privacy curtains, adjacent walls or columns, door swing arcs, etc. Power and signal outlets should be considered when selecting a channel location. Avoid oxygen, vacuum and air outlets.
- Ensure that the weight being mounted does not exceed the Load Ratings:  
OSHPD Pre-Approval Compliant: M-Series arms 60lbs (27 kg), VHM arms 40lbs (18 kg) MAX LOAD RATING  
Over 60lbs (27 kg): Not OSHPD Pre-Approved.
- Although Considerable effort has been made to ensure the safety of the above installation and/or Guidelines, the actual wall construction materials and installation itself is beyond the control of GCX or MINDRAY Corporation. Accordingly, GCX or MINDRAY Corporation will not be responsible for the failure of any such installations.

**OSHPD:** The GCX Seismic channel conforms to the California Office of Statewide Health Planning and Development (OSHPD) Seismic Preapproval requirements. The seismic channel and related hardware have been dynamically tested in order to be granted two different OSHPD Anchorage Preapprovals (OPA).

**OPA-0079:** Preapproval for the GCX 19" Seismic Channel including anchorage of channel to wall surface and the design/configuration of inner wall structure. Four different wall designs (A,B,C,D) are detailed in these Instruction (as well as the preapproval). Inner wall structural design must be verified by Structural Engineer of Record (SEOR), and determined to be adequate as detailed on the preapproval.

**OPA-0697:** Preapproval for the GCX 19" Seismic Channel including anchorage of channel to wall surface, not including the design/configuration of the inner wall structure. The Structural Engineer of Record (SEOR) must supply all of the inner wall structural details, which are to be designed and verified to support weights and forces in addition to all other loads as detailed on the preapproval.

#### **Locating the Wall Channel**

Devices and Wall Mounts may require channel placement outside of these guidelines. Access to device controls, Ergonomic requirements, and the "Range of Motion" that the Wall Mount provides should be considered before mounting the wall channel.

**Devices:** The bottom edge of a 19 inch (48.3 CM) Wall Channel is placed 54 inches (142.2 CM) above the floor, plus or minus 4 inches.

## ■ Seismic Wall Channel

The following Wall Channel Parts Reference Chart lists hardware quantities for the 19" Seismic Wall Channel. Longer Wall

Channels are available, and include additional hardware for the additional mounting points.

### Seismic Wall Channel Parts Reference

Item#	Description	Qty
1	#10 x 2" Oval Head Sheet Metal Screw (OHSMS)	7
2	#10 x 2" Pan Head Sheet Metal Screw (PHSMS)	3
3	#12 x 2 3/4" Sheet Metal Screw (SMS)	4
4	1/4-20 x 3" Pan Head Machine Screw w/Toggle Wings	4
5	Fixed Channel Stop	1
6	10-32 x 3/8" Flat Head Machine Screw (FHMS)	1
7	Depressible Channel Stop	1
8	Seismic Wall Channel	1



### Installing Seismic Wall Channel

Drill all screw holes in the 16-gauge or 2X6 Doug Fir anchorage using a 9/64" diameter twist drill bit for the #10 x 2" type "A" sheet metal screws supplied. Do not substitute screws. Install the top, centerline screw first. Level the channel and mark for the remaining 9 screws. The (3) Pan Head Screws are used in the 3 centerline holes. The bottom Fixed Stop, and all others holes use Oval Head Screws. Screws should be started and driven with ball handle drivers or torque limiting screw guns not exceeding 60 inch-pounds (6.7 Nm).

**Channel Placement Recommendation**

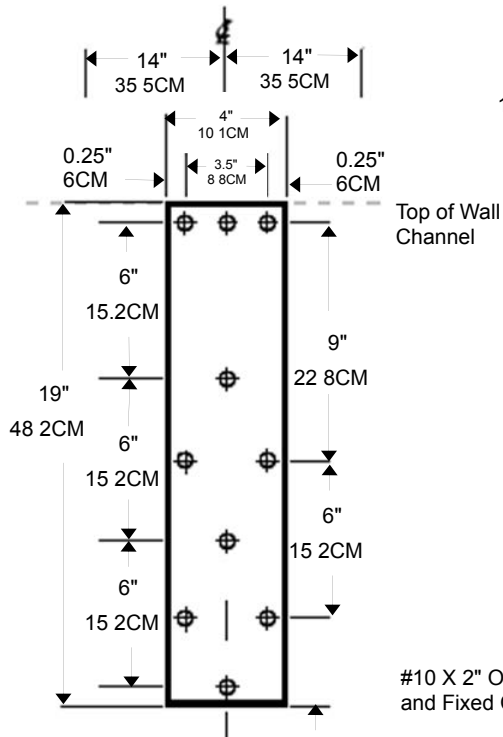

See the "Locating the Wall Channel" Section on page 3 for Recommended Mounting Height above floor.

**Hardware Placement**

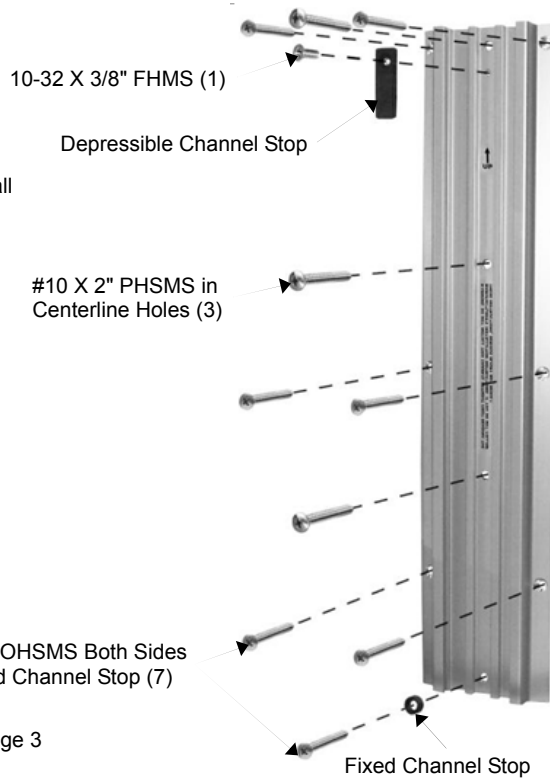

**Seismic Wall Channel Support Backing Methods**

The four anchorage methods illustrated (pages 6 – 7) represent Installations made to comply with California OSHPD requirements for the anchorage and installation of instrument support systems. Load tests were performed on a 10 ft. high wall using methods A, B, C, and D. Compliance with these written instructions is required for the installation of the system.

# METHODS OF SUPPORT BACKING

## Method-A

### Seismic

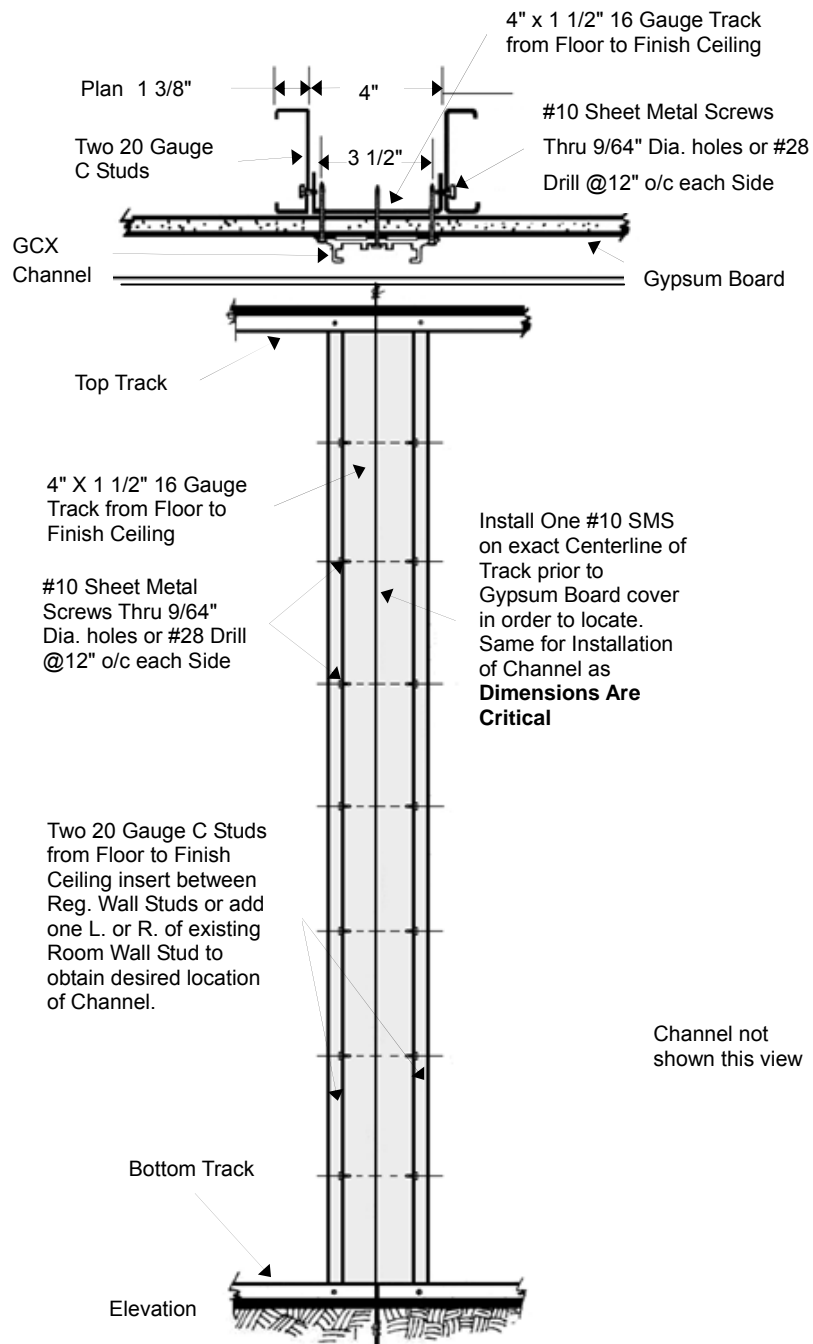

# METHODS OF SUPPORT BACKING

## Method-B

### Seismic

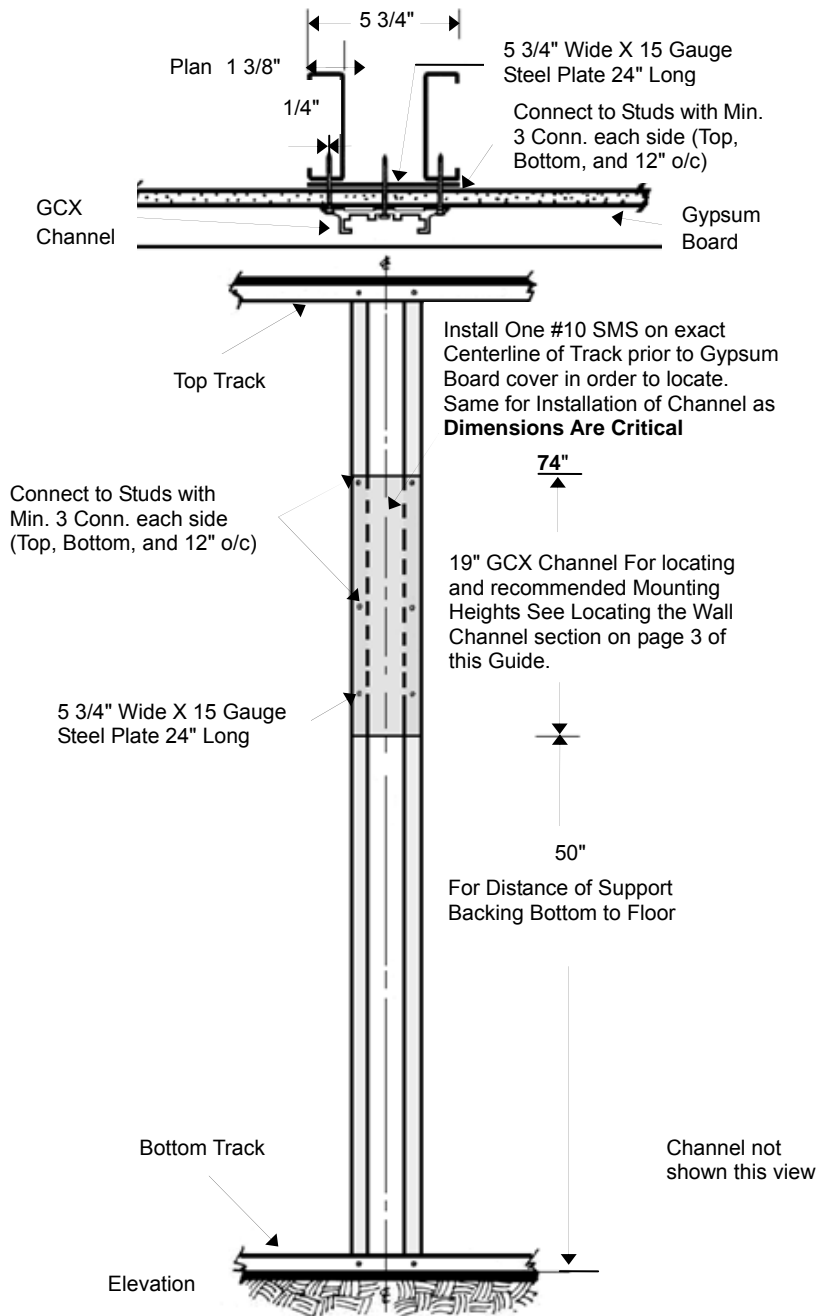

# METHODS OF SUPPORT BACKING

## Method-C

### Seismic

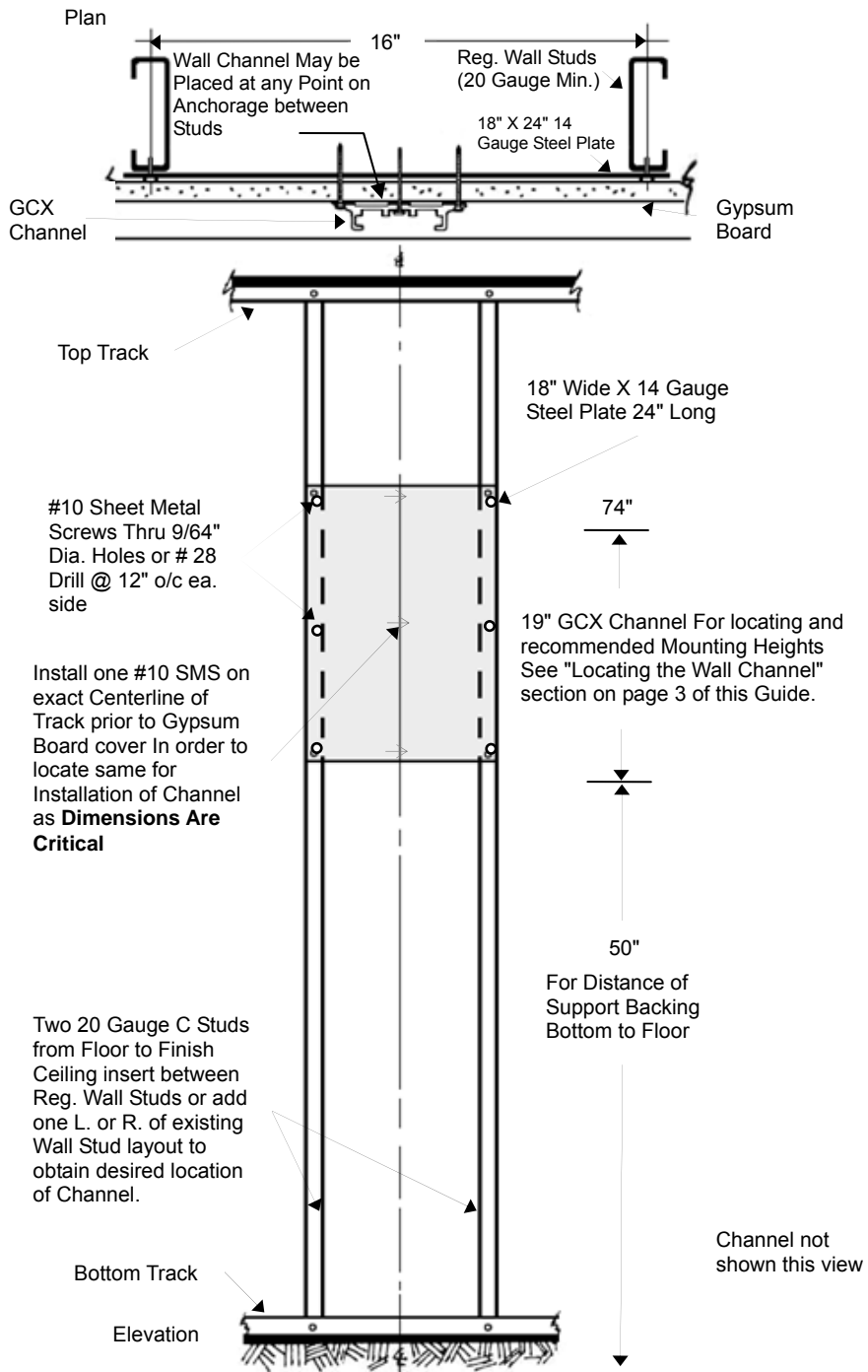

# METHODS OF SUPPORT BACKING

## Method-D

### Seismic

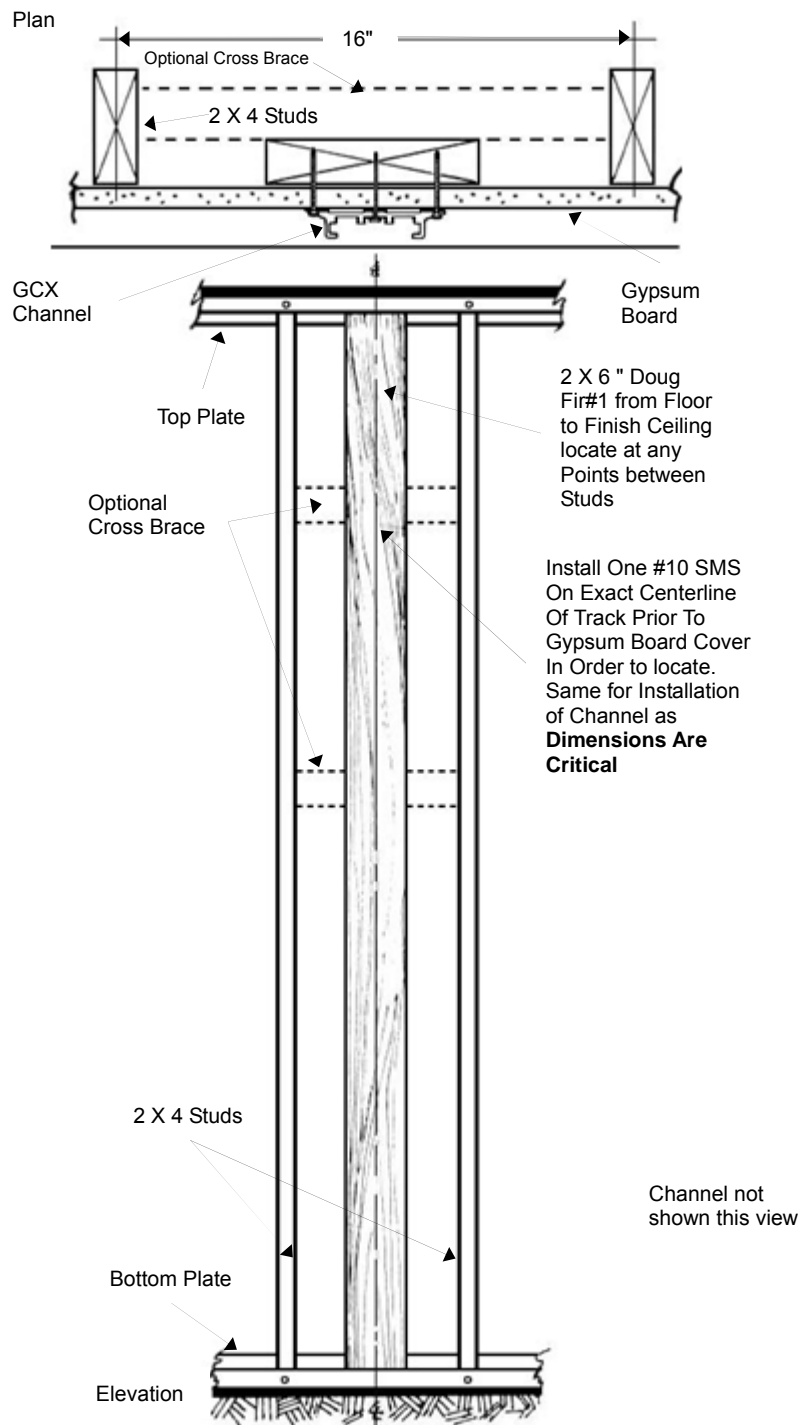



## ■ Standard Wall Channel

The following Wall Channel Parts Reference Chart lists hardware quantities for 19" Standard Wall Channel. Longer Wall

Channels are available, and include additional hardware to compensate for additional mounting points.

### Standard Wall Channel Part Reference

Item#	Description	Qty
1	#12 x 2 3/4" Sheet Metal Screw (SMS)	4
2	1/4-20 x 3" Pan Head Machine Screw w/Toggle Wings	4
3	Fixed Channel Stop	1
4	10-32 x 3/8" Flat Head Machine Screw (FHMS)	1
5	Depressible Channel Stop	1
6	Standard Wall Channel	1



### Installing the Standard Wall Channel

Drill 11/64" (17 mm) diameter holes for #12 X 2-3/4" high tensile Philips Head Screws. Install the top screw and level the channel, then mark and drill the other holes. Screws should be started and driven with ball handle drivers or torque limiting screw guns not exceeding 60 inch-pounds. Screws must pass through Channel, Drywall, and fully engage with Wood Stud or 16 Gauge Steel Stud.

Drill a 3/4" (19.5 mm) diameter holes for the 1/4-20 x 3" Pan Head Machine Screws with Toggle Wings. Toggle Wings should be used if Steel Wall Stud is less than 16 Gauge in thickness.

Installation Note: Seismic Wall Channel can be installed the same as Standard Wall Channel when OSHPD approval is not required.

**Channel Placement Recommendation**

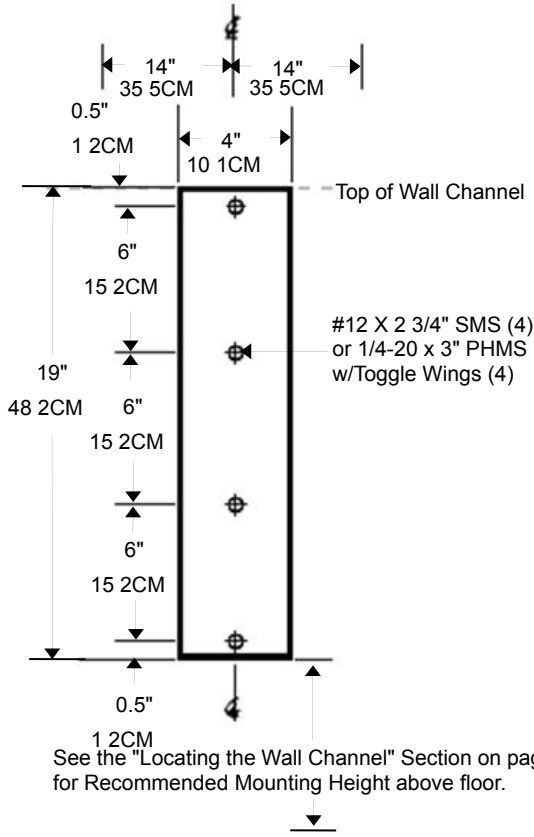

**Hardware Placement**

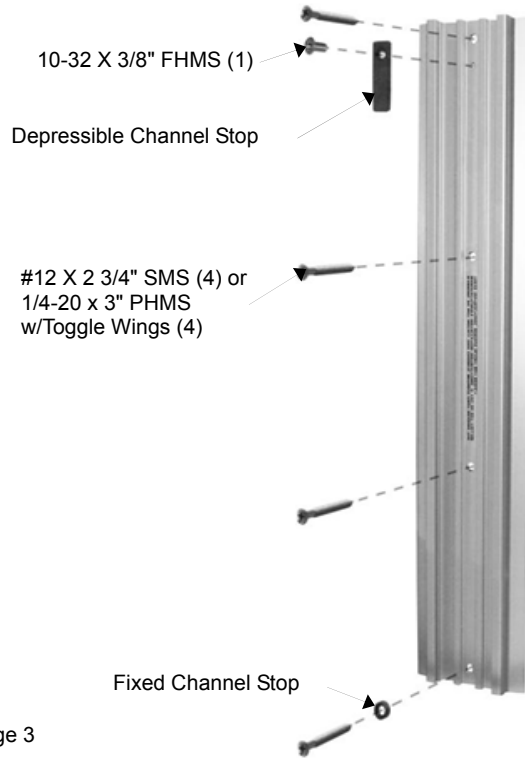

**Method-A  
Standard**

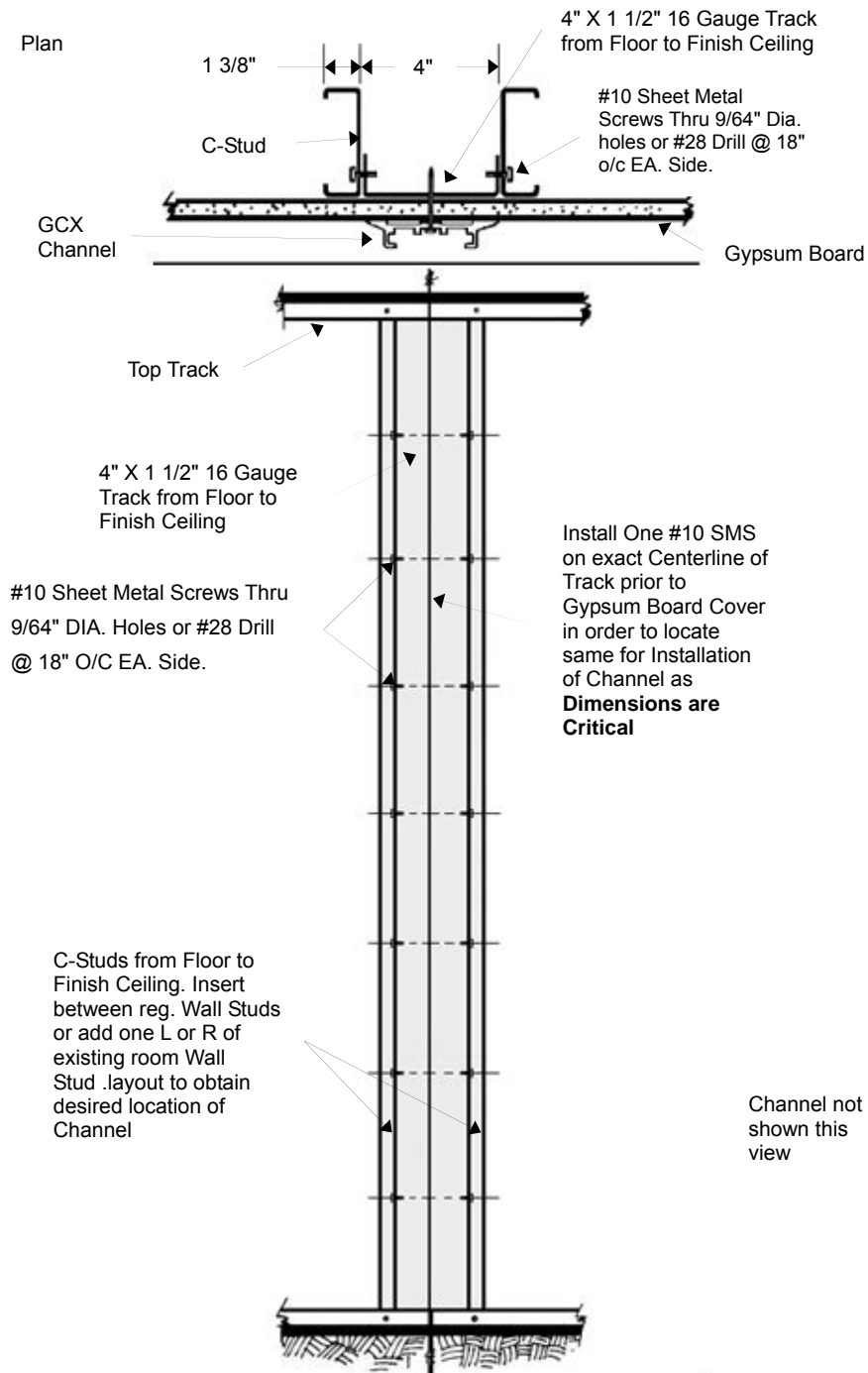

This Anchorage will allow for a Quick and Simple installation of the Standard Wall Channel. 16 Gauge Steel will prevent the material from extruding up the Shank of the Screw (Stripping). 11/64" Diameter holes are required for #12 X 2-3/4" High Tensile, Phillips Head Screws (4) installed down the Centerline. (Non-Seismic Applications).

A second Track can be used for Back to Back Installations. A 2" X 4" Wood Stud may be used if allowed by Local Building Codes.

**Drywall (Gypsum Board) over 16 Gauge Sheet Metal or Wood Studs:**

Locate the exact centerline of the stud. Drive a #4 finishing nail through the drywall to contact the stud. Withdraw and drive again 3/8" (9.5 mm) right and left until the edges of the stud have been located and hence the centerline determined. The wall channel's 4 inch (10.2 CM) width will cover these exploratory holes.

Drill 11/64" (17 mm) diameter holes for #12 X 2-3/4" high tensile Philips head screws in a single 16 gauge stud through

Channel Centerline, (4 places). Install the top screw and level the channel, then mark and drill the other holes.

**Drywall (Gypsum Board) over Sheet Metal Studs less than 16 Gauge:**

Locate the Centerline of the stud per the above instructions. Use 1/4-20 X 3" Pan Head Machine Screws and Toggle Wings. Drill 3/4" (19.5 mm) diameter holes with a sharp speed bore or twist drill (requires pilot hole). Note that the round stop at the bottom of the channel goes over the shank of the bottom screw. Insert screws through Wall Channel holes then affix the toggle wings to the screws. Insert toggle wings into previously drilled holes. Use a level to make sure the channel is vertical prior to final seating of the screws.

**Plaster Coat over Expanded Metal Lath on Steel Studs, Hollow Tile, Hollow Block:**

Drill 3/4" (19.5 mm) holes. Broach the holes in hard materials to allow for the toggle wing to pass through. Insert screws through Wall Channel holes then affix the toggle wings to the screws. Insert toggle wings into previously drilled holes. Use a level to make sure the channel is vertical prior to final seating of the screws.

**Concrete Walls:**

Concrete wall: Using six M6X65 Expansion screws to fix the wall channel.

1. Determining the locations of the holes of installing the guide rail on the wall based on the height of fixing the ultrasound machine. With drilled six  $\Phi 10$  mm and 40mm depth holes vertically on the wall , the hole intervals are shown as following:

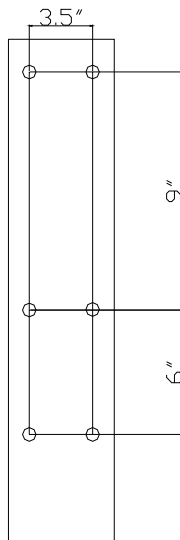

2. Aligning the guide rail with the holes on the wall and screw it through with six M6X65 expansion screws:

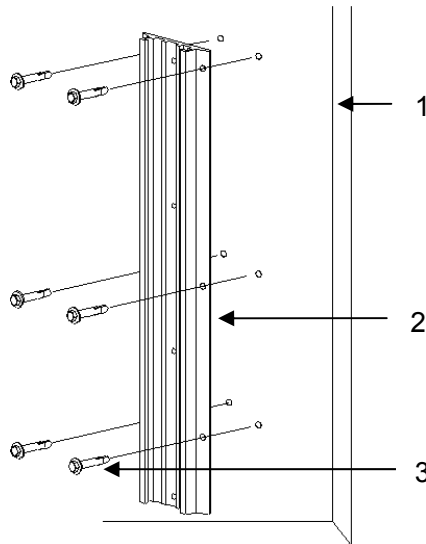

1-Wall ; 2-Wall Channel; 3-Expansion screw (M6X65)

**Through Wall, Back to Back Installations:**

Sufficient length 1/4-20 machine screws, nuts, washers and/or back plates must be obtained to mount the channel by drilling all the way through the thin partition wall. A Portalgn drill fixture is recommended for this procedure.

**Special Applications:**

Channels can be attached to a GCX 4" X 4" (10.2 x 10.2 CM), 1/8" (3.2 mm) wall aluminum support column or certain mullions, etc.. Contact GCX (Mindray Technical Service) to discuss solutions to wall mounting problems for any situation not covered by these guidelines.

## 2.1.2 Crane Channel

7"/17.8cm Channel with 38mm Post Clamps

The purpose of this guide is to:

- Describe attaching Channel to 38mm Post.



**Warning:** Ensure that the weight of the mount and instrument to be installed does not exceed 60lbs (27.2kg).



### Parts Reference

The following parts are included in this installation kit:

Item	Description	Qty
1	Clamping Blocks	2
2	Channel	1
3	10-32 x 5/8" Socket Head Cap Screw (SHCS)	1
4	5/32" Hex Wrench	1



1



2

### Tools Required:

- 5/32" Hex Wrench (provided)

### Attaching Mount to Pole

Using the 5/32" Hex Wrench (supplied), attach Channel to the 38mm post with (2) Clamping Blocks and (4) 10-32 x 5/8"

SHCS as shown below. Tighten screws equally (40 in/lb. minimum) until Clamping Blocks are secure.

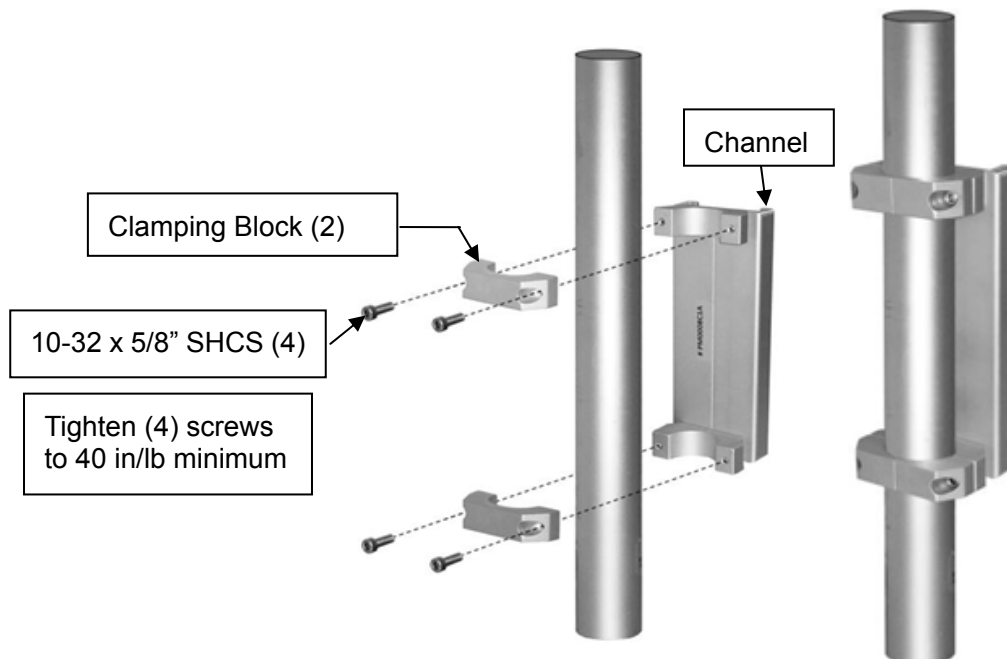

## 2.2 Arm



The purpose of this manual is to describe general installation, operation, and adjustment procedures for VHM™ Series Arms. This manual should be used in conjunction with any instrument-specific installation guides. Please read this manual and all instrument-specific installation material before installing or using this product.

## 2.2.1 Installation, Operation, and Maintenance

### Warnings

This section contains warnings regarding the installation, operation, and maintenance of the VHM Arm. This section must be read in its entirety before installing, operating, and maintaining the VHM Arm. Failure to follow these warnings may result in damage to equipment or injury to personnel.

#### Warnings:

- Do not position the VHM Arm or mounted instrument above a patient. Note that the VHM ARM has a wide range of motion both up/down and side to side. Please consider carefully the instrument being mounted and the proximity of the mounting assembly to other equipment, hospital personnel, and the patient. GCX (MINDRAY) recommends that the hospital's risk management personnel verify that the application is appropriate prior to installation and use of the VHM Arm.
- If the VHM Arm is wall mounted, verify that the channel has been installed and approved in accordance with the channel installation guide.
- Ensure that the weight of the instrument being mounted does not exceed the load rating of the VHM Arm. Check the bottom surface of the Arm for the "Maximum Load" label (see 5.2.2.1 for label location).
- The Height Locking Lever or Knob must be engaged when removing a mounted instrument from the VHM Arm.
- Stand to the side of the VHM Arm and mounted instrument and use caution when disengaging the Height Locking Lever. The total mounted load may have changed due to the addition or removal of equipment (other than primary instrument) while the Height Locking Lever was engaged. A change in the total load can cause a sudden downward or upward movement of the Arm when the Height Locking Lever is disengaged.
- The mounted device or arm may move suddenly due to normal wear or improper adjustment of the tilt and swivel functions (see Sections 5.2.4, 5.2.5.2, and 5.2.5.5) or ultimately, gas spring end of life. The VHM Arm must be inspected and adjusted at least two times per year. This inspection must include the following steps:
  1. With the device mounted, release the height lock and move the arm through its entire vertical range of motion. The load should maintain its position at every point in the travel of arm. If necessary, the counterbalance mechanism may be adjusted in accordance with section 5.2.4.
  2. Grasp the mounted device and swivel it from side to side. The device should swivel with some tension or resistance, not loosely. If necessary, the swivel tension may be adjusted in accordance with section 5.2.5.5.
  3. Grasp the Arm and pivot it from side to side at the channel attachment. The arm should pivot with some tension or resistance, not loosely. If necessary, the pivot tension may be adjusted in accordance with section 5.2.5.4.
  4. Grasp the mounted device and tilt it forward and back, through its entire range of motion. There should be enough tension or resistance in the tilt mechanism to prevent the device from tilting forward unexpectedly when in use.
  5. Inspect fasteners for looseness. Tighten as required for optimal operation and safety.



6. Due to risk of personal injury or damage to the equipment, the VHM Arm housing must never be disassembled by non-GCX personnel. Failure to comply will void the warranty.

Failure to periodically inspect and adjust the Arm as instructed may result in damage to equipment or injury. If you do not intend to periodically inspect the arm, the Height Locking Lever should be removed entirely to reduce unexpected movement of the arm. If regularly inspected, the VHM Arm should function properly for 5 to 10 years. If you are unable to adjust the arm or require service, contact GCX technical support at 800-228-2555 or Mindray Technical Service.

## 2.2.2 Installing the VHM Arm in the Channel

**2.2.2.1 Thread the Height Locking Lever, \*if provided, clockwise into the mounting hole in the right side of the Arm (below left). Turn Locking Lever clockwise to lock or counterclockwise to unlock. Installation Note: When the VHM arm is properly counterbalanced for the weight load, the arm will stay in the desired vertical position unless moved by the user. Engagement of the Height Locking Lever is necessary while changing the location of the entire Arm within the channel. Engagement of the Height Locking Lever is otherwise optional to prevent downward or upward movement. Refer to Section 5.2.4 (Adjusting Counterbalance) and Section 5.2.5.4 (Adjusting Height of the Mounted Instrument) for further information on use of the Height Locking Lever.**

*\*VHM Arms with a Spring Lock are equipped at the factory with a Locking Knob.*



**Note:** The Height Locking Lever is a multi- position clamping lever that operates by lifting, rotating, and releasing the handle.

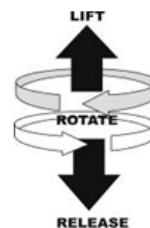

### VHM Arm with Spring Lock

This type of VHM Arm is designed for use with transport monitors only. The Locking Knob is installed at the factory. Ensure Locking Knob is in locked position before attempting to mount Arm in channel.

**Installation Note:** For proper function of the locking mechanism, the arm must be properly adjusted to counterbalance the weight of the mounted instrument (see section 5.2.3).

**Note:** Locking Knob operates by pulling and releasing Knob.



**2.2.2.2** While supporting the \*bottom of the Arm, guide the Slide into the top of the channel (below left) and move Arm to required mounting position.

**2.2.2.3** Using the 1/8" hex wrench provided, tighten four (4) set screws in Slide to secure position of Arm (below right).

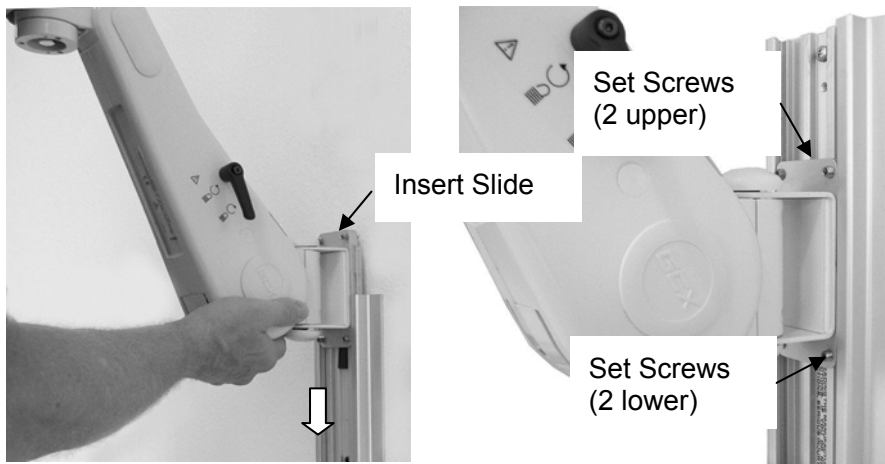

## 2.2.3 Mounting the Instrument on the VHM Arm

Most instruments will require the attachment of an instrument-specific Mounting Adapter provided by GCX or by the instrument supplier. Please install the Mounting Adapter in accordance with the installation guide included with the Adapter.

### 2.2.3.1 Installing the Support

**Maximum load:** 9.0kg

Disassembly tool required: Phillips screwdriver

1. Align the screw holes on the main unit support with the screw holes on the arm.
2. Tighten (3) 10-32 x 3/4" FHMS screws.



3. Align the screw holes on the main unit support with the screw holes on the connection plate of the main unit support.
4. Tighten (3) 10-32 x 1/2" FHMS screws.



(3) 10-32 x 1/2" FHMS

### 2.2.3.2 Installing the Main Unit



**WARNING:** The arm must be locked before installing the display.

1. Snap the flange of the bracket into the installation slot towards arrow's direction.

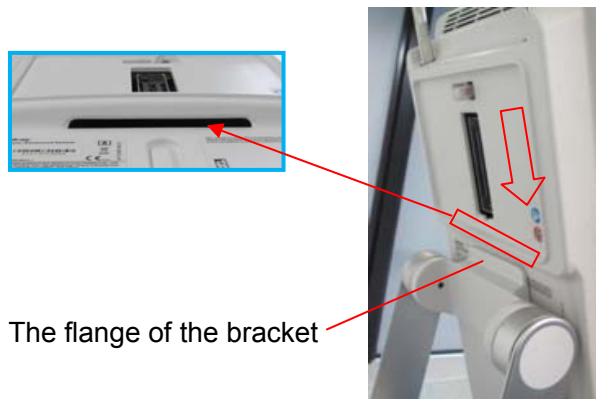

The flange of the bracket

2. Push the display towards arrow's direction gently until the spring pin accesses the limit hole.

**Note:** If the spring pin does not access the limit hole, pull down the spring pin, and then push the display gently.

After the installation is completed, push the display opposite to see whether the display is tightened.

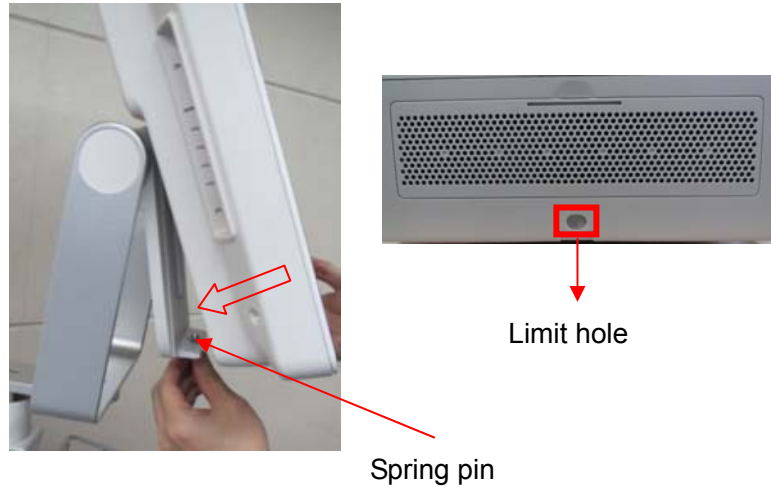

## 2.2.4 Adjusting Counterbalance



**WARNING:** Do not attempt counterbalance adjustment unless the instrument and accessories are mounted on the Arm. Use caution while performing this procedure.

The VHM Arm must be adjusted to counterbalance the mounted instrument throughout the Arm's vertical range of motion. When properly counterbalanced, the VHM Arm will maintain its height without engagement of the Height Locking Lever or Locking Knob. Because instrument weights vary, adjustment will typically be required to achieve optimal performance. A 1/2" [13mm] socket wrench is provided for this critical adjustment.

### To adjust counterbalance:

1. Grasp the Arm behind the mounted instrument(s) and carefully move the Arm to a horizontal position that allows access to the Adjuster Cover (below left). Lock Arm in horizontal position.
2. Open the Adjuster Cover by inserting a flat blade screwdriver in the slot at the rear of the Cover and prying upward. If necessary unlock and readjust the Arm until the Counterbalance Adjuster bolt is accessible through the Adjuster Cover (below center). Lock Arm when Counterbalance Adjuster is accessible.
3. With the 1/2" [13mm] socket wrench on the Adjuster, carefully unlock the arm. Turn the Adjuster counterclockwise (CCW) to increase counterbalance force, or clockwise (CW) to decrease counterbalance force. Counterbalance is correctly adjusted when the mounted instrument can be moved up or down with minimal force and does not rise or fall after releasing the Arm.

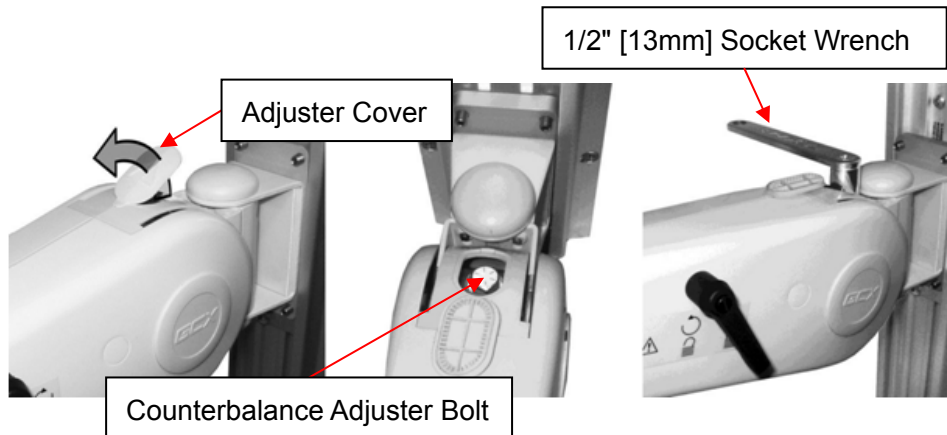

4. Close the Adjuster Cover.

## 2.2.5 Operating and Adjusting the VHM Arm

Check pivot, tilt, and front swivel mechanisms for proper tension. Refer to the applicable section and follow the adjustment procedure.

### 2.2.5.1 Counterbalance Adjustment - See Section 5.2.4

### 2.2.5.2 Adjusting Height of the Mounted Instrument

#### **WARNING:**

- Do not attempt to adjust height without instrument being mounted on Arm.
- Stand to the side of the VHM Arm and mounted instrument and use caution when disengaging the Height Locking Lever. The total mounted load may have changed due to the addition or removal of equipment (other than primary instrument) while the Height Locking Lever was engaged. A change in the total load can cause a sudden downward or upward movement of the Arm when the Height Locking Lever is disengaged.



Grasp mounted instrument on sides (or handle) and move to desired height. When Arm is counterbalanced correctly (sec 4.0), it will maintain position when adjusted to a new height. **Note:** Disengagement/re-engagement of the Height Locking Lever may be necessary during vertical adjustment of mounted instrument (see **WARNING** above). Engagement of the Height Locking Lever is not required during normal operation of the counterbalanced instrument.

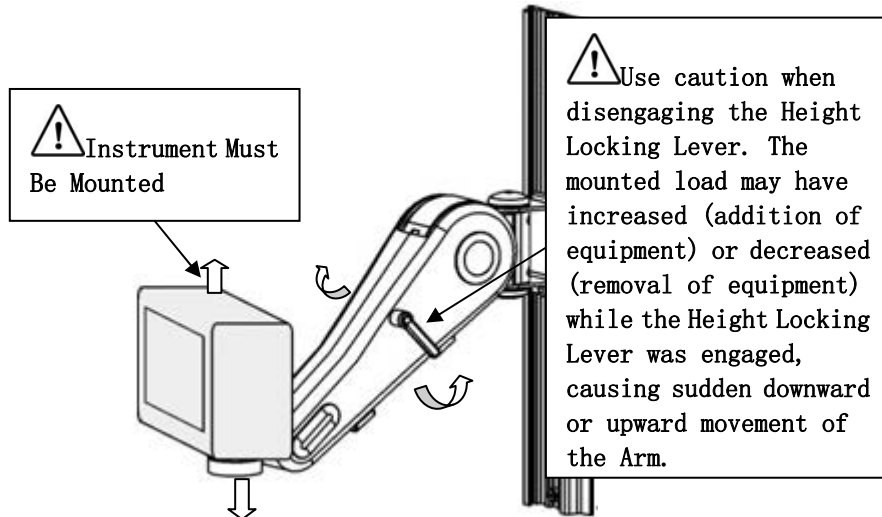

### 2.2.5.3 Positioning VHM Arm in Channel

**!** **Caution:** Do not attempt to remove the Arm from the Channel while Arm is loaded with an instrument.\

1. Lock the Arm in highest vertical position using Height Locking Lever or Locking Knob.
2. Using the 1/8" hex wrench provided, loosen four (4) set screws in Slide.
3. Relieve the weight of the mounted instrument by lifting against the underside of the Arm, near the instrument.

Simultaneously, push up or pull down the opposite end of the Arm immediately in front of the Slide.

4. Tighten four (4) set screws.

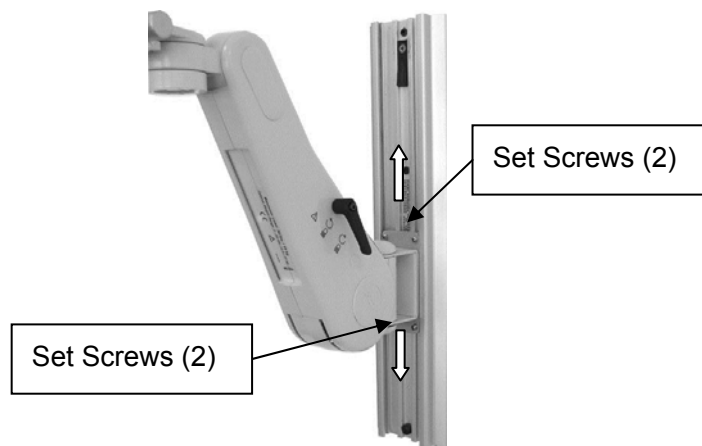

### 2.2.5.4 Pivoting the VHM Arm and Adjusting Pivot Tension

1. To pivot Arm at Channel, simply push on side of Arm.
2. To adjust pivot tension, remove upper and lower bolt caps from Pivot Bolt. Using the 1/2" [13mm] socket wrench provided and a 1/2" [13mm] box or open-end wrench, tighten or loosen Pivot Bolt and Hex Nut to desired tension. Reinstall bolt caps on each end of Pivot Bolt.

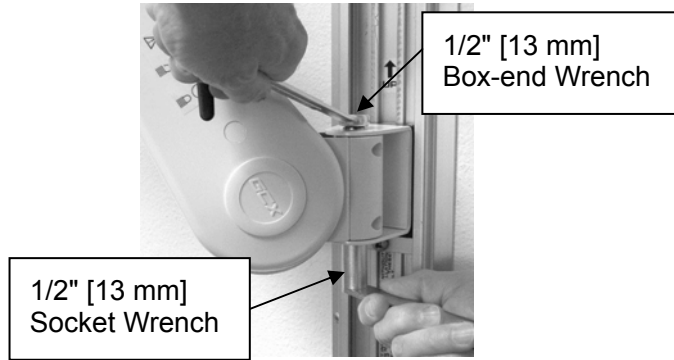

### 2.2.5.5 Swiveling the Mounted Instrument and Adjusting Swivel Tension

1. To swivel mounted instrument, simply push or pull instrument.
2. To adjust swivel tension, tighten or loosen the Swivel Tension Nut using the 1/2" [13 mm] socket wrench provided.

**Installation Note:** It may be necessary to remove an existing down post from the swivel cup to gain access to the Swivel Tension Nut.

 **Warning:** Swivel tension nut must be torqued to a minimum of 20 in- lbs [2.3 N-m].

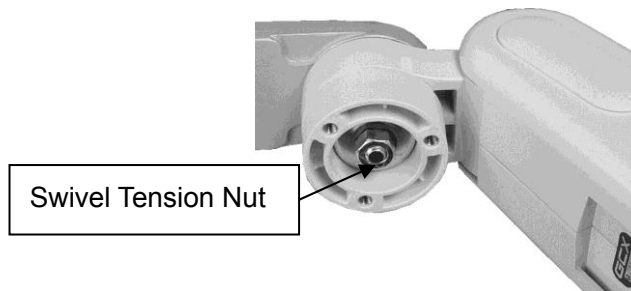

### 2.2.6 Cable Management

A Cable Guide is provided to facilitate routing of cables along the underside of the \*arm. Squeeze the Cable Guide until its edges snap into the grooves in the bottom surface of the arm. Leave some extra cable loose at the front and rear of the arm to prevent cable binding, connect or damage, or Cable Guide damage.

Guides snap into grooves on the bottom of the Extension.

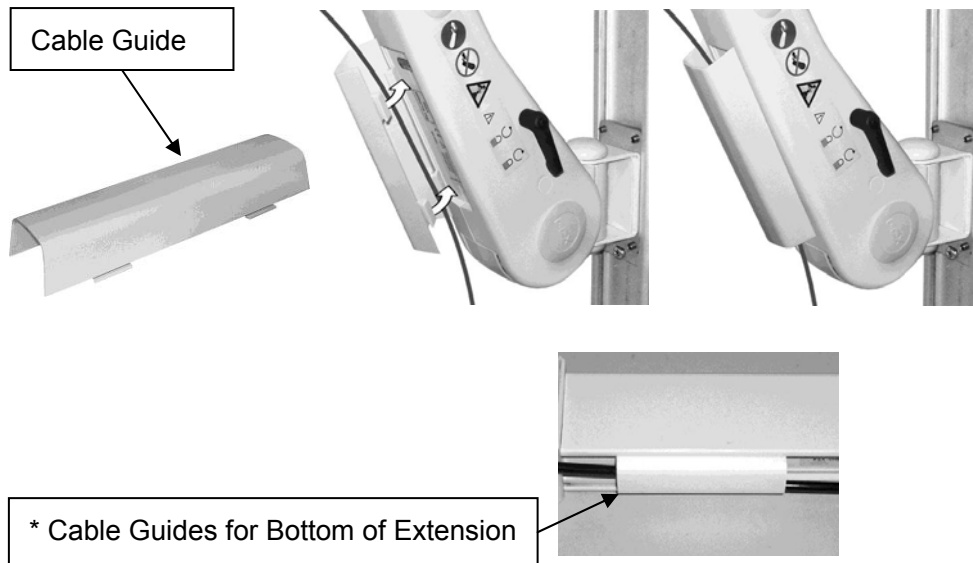

## 2.2.7 Routine Maintenance

Periodically inspect all tilting, swiveling, pivoting, and mounting hardware. Tighten or adjust as necessary for optimal operation and safety.

## 2.2.8 Cleaning the Mounting Assembly

1. The mounting assembly may be cleaned with most mild, non-abrasive solutions commonly used in the hospital environment (e.g. diluted bleach, ammonia, or alcohol solutions).
2. The surface finish will be permanently damaged by strong chemicals and solvents such as acetone and trichloroethylene.
3. Steel wool or other abrasive material should *never* be used.
4. Damage caused by the use of unapproved substances or processes will not be warranted. We recommend testing any cleaning solution on a small area of the arm that is not visible, to verify compatibility.
5. Never submerge or allow liquids to enter the arm. Wipe any cleaning agents off of the arm immediately using a water-dampened cloth. Dry the arm thoroughly after cleaning.

**CAUTION:** GCX (MINDRAY) makes no claims regarding the efficacy of the listed chemicals or processes as a means for controlling infection. Consult your hospital's infection control officer or epidemiologist.

## 2.2.9 Troubleshooting the VHM Arm

Symptom	Possible Cause	Remedy
Mounted instrument does not appear level or parallel to the floor.	Channel not plumb. Check with level.	Adjust Channel to plumb, or reinstall Channel.
	Weight of instrument not compatible with Load Rating of the Arm.	Mount instrument on arm with compatible Load Rating.



Symptom	Possible Cause	Remedy
	Swivel hardware loose.	Adjust Swivel Nut (section 5.5.5.5).
	Pivot hardware loose.	Adjust Pivot Bolt (section 5.5.5.4).
	Mounting surface (e.g. wall, side of anesthesia machine, etc.) not structurally sound (does not hold mounting hardware).	Mounting surface must be reinforced or Channel must be relocated.
	Channel loose at mounting surface.	Check for plumb and tighten, or relocate (reinstall) Channel.
	Set Screws (4) in Slide are loose.	Reposition Arm and tighten set screws.
Instrument drifts up or down when the Arm is unlocked.	Arm not counterbalanced correctly for weight of the instrument.	Perform counterbalance adjustment per section 5.2.4.
	Weight of mounted instrument (load) not compatible with Load Rating of Arm.	Use arm with compatible Load Rating, and perform counterbalance adjustment per section 5.5.5.5.
Arm pivots too freely.	Pivot Bolt too loose.	Adjust Pivot Bolt (section 5.5.5.4).
Arm does not pivot easily.	Pivot Bolt too tight.	
Instrument swivels too freely.	Swivel Nut too loose.	Adjust Swivel Nut (section 5.5.5.5).
Instrument difficult to swivel.	Swivel Nut too tight.	
Instrument difficult to tilt.	Tilt Adjustment Lever too tight.	Adjust tilt and tilt tension per section 5.5.5.6.
	Excessive tilt tension.	
Instrument will not maintain tilt position.	Tilt Adjustment Lever too loose.	
	Insufficient tilt tension.	
Arm difficult to move up or down when unlocked.	Arm not counterbalanced correctly for weight of mounted instrument.	Perform counterbalance adjustment per section 5.2.4.
Arm inadvertently slides down Channel.	Set Screws (4) in Slide are loose.	Reposition Arm and tighten set screws.
Locking Knob (Arms with Spring Lock) will not pull out (release).	Arm not counterbalanced correctly for weight of mounted instrument.	Perform counterbalance adjustment per section 5.2.4.
	Weight of mounted instrument (load) not compatible with Load Rating of Arm.	
Counterbalance Bolt difficult to adjust.	Arm not locked in a horizontal position.	Reposition Arm and lock in horizontal position.

## 2.3 Bracket of the adapter

The purpose of this guide is to describe wall mounting of a typical power supply.

Min. Power Supply Size Using 12" [30.5 cm] Hook & Loop Straps	Max. Power Supply Size Using 18" [45.7cm] Hook & Loop Straps
1.4" [3.56 cm] x 2.3" [5.84 cm] or 7.4" [18.8 cm] perimeter	4.0" [10.16 cm] x 4.0" [10.16 cm] or 16" [40.6 cm] perimeter

### Parts Reference

The following parts and hardware are included with this installation kit (see photo for parts; hardware not shown):

Item	Description	Qty
1	Power Supply Mount (with 12" Hook & Loop Straps)	1
2	Cable Retainer, Nylon	1
3	#8-32 x 3/8" Pan Head Machine Screw (PHMS)	1
4	#8 Flat Washer	1
5	Hook-and-Loop Strap, 18"	2



**Tools Required:** 1/8" hex wrench (provided) Phillips screwdriver (not provided).

**Maximum load:** 1.5kg

### Mounting the Power Supply Bracket in the Channel

1. Insert the slide section of the Power Supply bracket into the GCX channel, position in desired location.

**Installation note:** The bracket can be oriented vertically or horizontally as shown, depending on the application.

2. Secure the Power Supply Bracket within the channel by tightening the 1/4-20 set screw using the 1/8" hex wrench.



Vertical Orientation

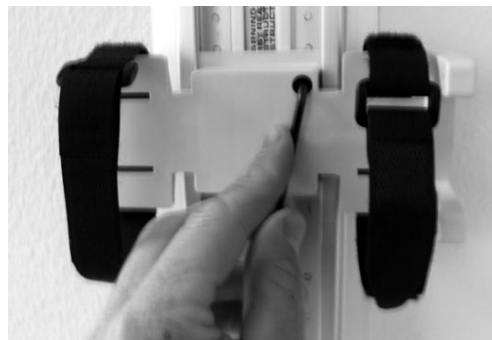

Horizontal Orientation

## Mounting the Power Supply in the Bracket

1. Place power supply in Bracket, insert hook-and-loop straps through rings, pull straps tight and press firmly (below left).

**Installation Note:** This Bracket is pre-assembled with two (2) 12" hook-and-loop straps. These straps securely hold most power supplies, but may be replaced with 18" straps (provided) for larger power supplies.

2. Loop power cable through Nylon Cable Retainer and fasten Retainer to bottom of Bracket with one (1) #8-32 x 3/8" PHMS and #8 flat washer (below right).



**Secure Velcro Straps**



**Secure Power Cable  
with Retainer**



**Assembled Power Supply Bracket**

## Routine Maintenance

Periodically inspect all hardware associated with the mounting system. Tighten or adjust as necessary for optimal operation and safety.

## Cleaning the Mounting Assembly

1. The mounting assembly may be cleaned with most mild, non-abrasive solutions commonly used in the hospital environment (e.g. diluted bleach, ammonia, or alcohol solutions).
2. The surface finish will be permanently damaged by strong chemicals and solvents such as acetone and trichloroethylene.
3. Do not use steel wool or other abrasive material to clean the mounting assembly.
4. Damage caused by the use of unapproved substances or processes will not be covered by warranty. We recommend testing of any cleaning solution on a small area of the arm that is not visible to verify compatibility.
5. Do not submerge or allow liquids to enter the arm. Wipe any cleaning agents off of the arm immediately using a water-dampened cloth. Dry the arm thoroughly after cleaning.

**CAUTION:** GCX (MINDRAY) makes no claims regarding the efficacy of the listed chemicals or processes as a means for controlling infection. Consult your hospital's infection control officer or epidemiologist.

## 2.4 Storage Basket

Maximum load: 2.0kg

Disassembly tool required: Phillips screwdriver

1. Align the screw holes on the storage basket with the screw holes on the connection plate.
2. To fix the storage basket onto the connection plate, use the Phillips screwdriver to tighten (4) 10-32 x 3/8" PHMS screws.

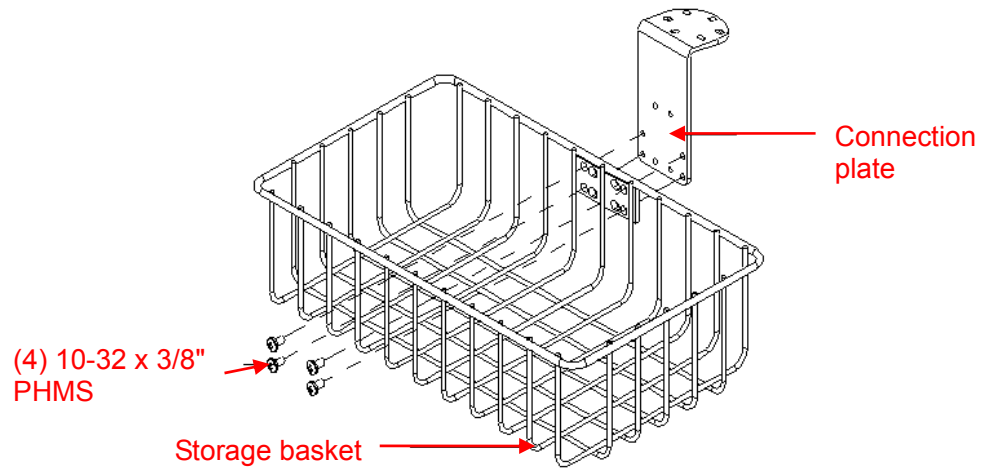

3. Align the screw holes on the connection plate with the screw holes on the pivot joint.
4. Use 5/32 (4 mm) hex wrench to tighten (3) 10-32 x 3/8" SHCS.

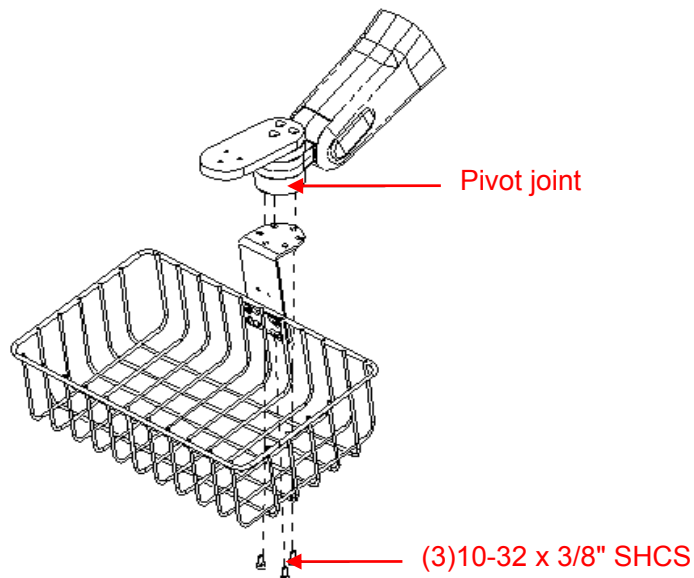

# 3 Mechanical Safety Test

---

This section mainly focus on conducting the mechanical safety test on the mechanical strength and mechanical function of the important components in ultrasound equipment.

Main methods of evaluation in the test are: Visual check and operation testing.

If the test results does not pass, then the machine must be stopped and appreciate measures be taken as the system could be in an abnormal condition.

Flowchart for the test is shown below.

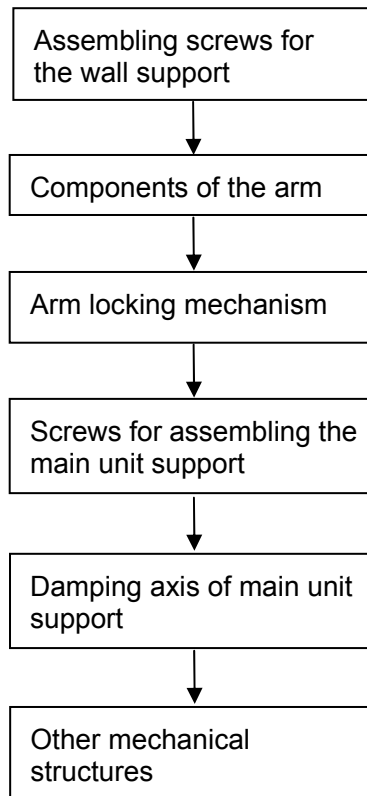

**Figure of flowchart for conducting Mechanical safety test**

Table for mechanical safety test

Content	Method	Tool
Assembling screws for the wall mount	Visual examination: Check that the support assembly board does not show any signs of warping. Test with the wrench: check that none of the assembling screws are loose.	Inner hexagon spanner

Content	Method	Tool
Arm assembly	a) Swivel the arm on the vertical side. The arm reaches the desired angle on the vertical side. No cracks happen. b) Push the arm on the vertical side. The arm reaches the desired angle on the vertical side. No cracks happen.	N/A
Arm locking mechanism	Turn the level on the support arm pivot to position. The arm should not be able to move from side to side.	N/A
Screws for assembling the main unit support	Test with the wrench: check that none of the assembling screws are loose.	Cross-headed screwdriver
Damping axis of the main unit support	Swivel the main unit support to desired angle. The main unit keeps stable. The motion of the damping axis is flexible. No cracks or abnormality happen.	N/A
Other mechanical structures	Check that none of the other mechanical structure show signs of loose components, cracks/fractures on the outer surface or have exposed conducting parts.	N/A

