

Operating Instructions



Anesthesia System

mindray

Operating Instructions



Anesthesia System

mindray

OPTIMIZER® is a registered trademark of Mindray DS USA, Inc.

Copyright © Mindray DS USA, Inc., 2020-2024. All rights reserved. Contents of this publication may not be reproduced in any form without permission of Mindray DS USA, Inc.

Table of Content

Safety	1 - 1
Safety Information	1 - 2
Warnings.....	1 - 2
Cautions	1 - 7
Notes.....	1 - 9
Symbols.....	1 - 11
Product Description	2 - 1
Introduction	2 - 2
Indications For Use.....	2 - 2
Structure and Composition	2 - 2
Functions and Features.....	2 - 2
Equipment Views.....	2 - 4
Main Unit (Front View).....	2 - 4
Main Unit (Rear View).....	2 - 7
Main Unit (Left View)	2 - 9
Main Unit (Right View).....	2 - 11
Main Unit (Top View).....	2 - 12
Breathing System	2 - 13
Negative Pressure Suction Device.....	2 - 14
Installation and Disassembly	3 - 1
Unpacking.....	3 - 3
Initial Setup.....	3 - 3
Breathing System	3 - 3
Vaporizer	3 - 4
Filling the Anesthetic Agent.....	3 - 5
Draining the Anesthetic Agent.....	3 - 7
Negative Pressure Suction Device.....	3 - 8
Turn on Negative Pressure Suction Device.....	3 - 9
Turn off Negative Pressure Suction Device.....	3 - 9
High-flow Nasal Cannula Oxygen (HFNC) Tube	3 - 10
Anesthetic Gas Scavenging System (AGSS).....	3 - 11
Active AGSS	3 - 11
Passive AGSS	3 - 12
Connect Anesthesia System with Information System	3 - 14
Connect Anesthesia System with Information System Through Serial Interface	3 - 14
Connect Anesthesia System with Information System Through Ethernet.....	3 - 14
Connect Anesthesia System to Patient Monitor	3 - 15
Connect Anesthesia System to Patient Monitor Through Serial Interface	3 - 15
Connect Anesthesia System with eGateway.....	3 - 15
System Interface	4 - 1
Main Screen	4 - 2
System Information Title	4 - 3
Patient Information.....	4 - 3
Set Patient Information in Anesthesia System	4 - 5
Retrieve Patient Information from ADT Server	4 - 5
Synchronize Patient Information	4 - 5
Timer (Elapsed Timer/Countdown Timer).....	4 - 6
Alarm and Prompt Message	4 - 7
Audio Pause/Alarm Reset icon	4 - 7
Screen Brightness.....	4 - 8

Volume	4 - 8
Date and Time	4 - 8
Battery Status	4 - 9
Fresh Gas Flow Display	4 - 10
Electronic Flow Control System	4 - 10
Total Flow Control Mode	4 - 11
Direct Flow Control mode	4 - 12
OPTIMIZER®	4 - 13
Backup Flow Control System.....	4 - 15
Waveform/Parameter/Spirometry/Trend Display Zone.....	4 - 15
Waveform/Parameter Screen.....	4 - 17
Spirometry Screen.....	4 - 17
Loop Type	4 - 18
Show Reference	4 - 18
Save Loop	4 - 19
Review Loops	4 - 19
Freeze loop	4 - 21
Mini Trends Screen.....	4 - 21
Compl/PEEP Trend Screen	4 - 22
Ventilation Mode Tabs.....	4 - 23
System Soft Key.....	4 - 23
History.....	4 - 24
List Trends	4 - 24
Graphic Trends	4 - 25
Event Log	4 - 26
Screen	4 - 26
Export	4 - 27
Lung Recruitment (Optional)	4 - 27
Flow Pause	4 - 27
Cardiac Bypass Mode	4 - 28
Screens	4 - 28
Alarms	4 - 28
Alarm Reset.....	4 - 28
Audio Pause.....	4 - 28
Setup Menu	4 - 28
Ventilation.....	4 - 29
Oxygen (O2).....	4 - 31
AG Settings (AG module configured).....	4 - 31
Information	4 - 31
Screen	4 - 33
Export System Data	4 - 34
Calibrate.....	4 - 35
System.....	4 - 35
Calibrate	4 - 35
Setup	4 - 37
Profiles	4 - 40
Network	4 - 42
Information	4 - 45
Service Tab.....	4 - 46
Status Screen.....	4 - 46
Volume Exchanger	4 - 46
Automatic Ventilation, Flow Pause or Bypass	4 - 46

Manual Ventilation	4 - 46
Gas Supply Pressure Monitoring.....	4 - 46
Vaporizer.....	4 - 47
AGSS.....	4 - 48
Preoperative Tests.....	5 - 1
Requirements of Preoperative Tests	5 - 2
Preoperative Checklist.....	5 - 3
Introduction.....	5 - 3
Suggested Preoperative Checklist	5 - 3
Inspect the System.....	5 - 5
System Check.....	5 - 6
Auto System Check	5 - 6
Leak & Compliance Test	5 - 7
Vaporizer Test	5 - 7
Power Failure Alarm Test.....	5 - 7
Pipeline Test.....	5 - 7
O ₂ Pipeline Test.....	5 - 7
N ₂ O Pipeline Test.....	5 - 8
Air Pipeline Test.....	5 - 8
Basic Ventilation Test	5 - 9
Backup Gas Cylinder Test	5 - 9
Check Cylinder Pressure.....	5 - 9
High Pressure Leak Test of O ₂ Cylinders	5 - 10
High Pressure Leak Test of N ₂ O Cylinders	5 - 10
High Pressure Leak Test of Air Cylinders	5 - 10
Flow Control System Test.....	5 - 10
Breathing System Test.....	5 - 12
Inspiratory and Expiratory Check Valve Tests	5 - 12
APL Valve Test.....	5 - 12
Alarm Test	5 - 13
Prepare for Alarm Tests	5 - 13
O ₂ Concentration Monitoring and Alarm Test.....	5 - 13
Minute Volume (MV) Too Low Alarm Test.....	5 - 14
Apnea Alarm Test	5 - 14
Continuous Airway Pressure Too High Alarm Test.....	5 - 15
Airway Pressure (Paw) Too High Alarm Test.....	5 - 15
Airway Pressure (Paw) Too Low Alarm Test.....	5 - 15
AG Module Alarm Test.....	5 - 15
Inspect the AGSS	5 - 16
Check Passive AGSS.....	5 - 16
Inspect the Negative Pressure Suction Device	5 - 16
Pre-operation Preparations	5 - 16
Operations.....	6 - 1
Powering On the Anesthesia System.....	6 - 2
Powering Off the Anesthesia System.....	6 - 2
Patient Setup.....	6 - 3
Standby Mode	6 - 3
Enter Standby mode	6 - 3
Exit Standby mode	6 - 4
Set Patient Information	6 - 4
O ₂ Sensor Calibration.....	6 - 4
Set Fresh Gas.....	6 - 4

Set O ₂ , N ₂ O and Air Inputs	6 - 4
Set Anesthetic Agent	6 - 4
Select the Desired Anesthetic Agent	6 - 5
Adjust the Concentration of Anesthetic Agent	6 - 5
Set Ventilation	6 - 5
Change Ventilation Mode	6 - 5
Set Manual Ventilation Mode.....	6 - 6
Settings Before Starting the Automatic Ventilation Mode.....	6 - 7
Volume Control Ventilation (VCV)	6 - 7
Set Pressure Control Ventilation (PCV)	6 - 8
Set Pressure Control Ventilation - Volume Guarantee (PCV-VG).....	6 - 9
Synchronized Intermittent Mandatory Ventilation (SIMV).....	6 - 9
Synchronized Intermittent Mandatory Ventilation–Volume Control (SIMV-VC)	6 - 10
Synchronized Intermittent Mandatory Ventilation–Pressure Control (SIMV-PC)	6 - 10
Synchronized Intermittent Mandatory Ventilation–Volume Guarantee (SIMV-VG)	6 - 10
Set Continuous Positive Airway Pressure/Pressure Support Ventilation (CPAP/PS).....	6 - 13
Set Airway Pressure Release Ventilation (APRV) (Optional)	6 - 14
Lung Recruitment Ventilation (Optional)	6 - 14
One-Step Recruitment	6 - 15
Multi-Step Recruitment	6 - 16
Parameter Monitoring	6 - 17
Freeze Trend	6 - 17
Other Features.....	6 - 17
Auxiliary Common Gas Outlet (ACGO) Mode.....	6 - 17
Monitor.....	6 - 18
Cardiac Bypass Mode	6 - 19
High-flow Nasal Cannula Oxygen (HFNC)	6 - 19
Start Automatic Ventilation.....	6 - 20
Stop Automatic Ventilation.....	6 - 21
Relationships of Ventilation Parameters.....	6 - 21
Anesthetic Gases and O₂ Concentration Monitoring	7 - 1
Introduction	7 - 2
MAC Values.....	7 - 3
Agent Usage Calculation	7 - 4
Agent Consumption Speed.....	7 - 4
Identify External AG Module	7 - 5
AG Measurement Preparation.....	7 - 6
AG Module Settings.....	7 - 7
Set Operating Mode	7 - 7
Set AG Flow Rate.....	7 - 7
Set CO ₂ Unit.....	7 - 7
Set CO ₂ Scale.....	7 - 7
Set O ₂ Scale.....	7 - 7
Set N ₂ O Scale	7 - 7
Set AA Scale	7 - 8
Set Alarm Limits	7 - 8
Measurement Limits.....	7 - 9
Troubleshooting.....	7 - 10
Sample Gas Recirculation.....	7 - 10
Calibrate the AG Module	7 - 11
Alarms and Messages	8 - 1
Introduction	8 - 2

Alarm System Self-Test	8 - 2
Types of Alarms and Messages.....	8 - 2
Alarm Indicators.....	8 - 2
Alarm Display.....	8 - 4
Display Rules of Alarm Messages.....	8 - 5
Setting Alarm Volume	8 - 6
Pause Alarm Audio.....	8 - 7
Alarm Reset.....	8 - 7
Setting Alarm Limits.....	8 - 8
Auto Alarm Limits.....	8 - 10
View Active Alarms	8 - 11
Alarms and Prompt Messages	8 - 12
Physiological Alarm Messages.....	8 - 12
Technical Alarm Messages	8 - 17
Startup Alarm Messages	8 - 17
CPU Board Runtime Alarm	8 - 21
Power Supply Board Runtime Alarm	8 - 21
Flow Control System Runtime Alarm	8 - 23
Ventilator Control Board Runtime Alarm	8 - 24
AG Module Alarm Messages	8 - 27
AGSS Alarms	8 - 29
Vaporizer alarms	8 - 29
HFNC Module Alarms	8 - 30
Prompt Message.....	8 - 30
Prompt Messages Displayed in Alarms Area	8 - 30
Maintenance	9 - 1
Maintenance Schedule.....	9 - 3
Breathing System Service.....	9 - 3
Flow Sensor Calibration	9 - 4
O ₂ Sensor Calibration.....	9 - 4
21% Oxygen Calibration	9 - 4
100% O ₂ Calibration.....	9 - 5
O ₂ Sensor Calibration Error Codes.....	9 - 6
Handling of Gathered Water	9 - 7
Avoid Water Gathering.....	9 - 7
Clear Gathered Water.....	9 - 7
Electrical Safety Inspection	9 - 7
Auxiliary Outlet Test	9 - 8
Electrical Safety Test.....	9 - 8
Cleaning and Disinfection.....	9 - 8
Cleaning Agents and Disinfectors/Autoclaving	9 - 9
Exterior	9 - 10
Breathing System	9 - 11
Disassembly	9 - 11
Cleaning and Disinfection (Choose One)	9 - 18
Autoclaving (Additional Reprocessing)	9 - 19
Reassembly	9 - 19
Check Before the Next Use	9 - 27
Negative Pressure Suction Device.....	9 - 27
Disassembly	9 - 27
Cleaning	9 - 28
Disinfection	9 - 28

Reassembly	9 - 28
Check Before the Next Use	9 - 29
Periodic Maintenance.....	9 - 29
Product Specifications.....	10 - 1
Standards Compliance	10 - 2
Safety Designations.....	10 - 4
Physical Specifications.....	10 - 4
Environmental Specifications	10 - 6
Electrical Specifications.....	10 - 6
Main Electrical Power Specifications	10 - 6
Battery Power Specifications.....	10 - 7
Auxiliary Electrical Outlets.....	10 - 8
Communication Ports.....	10 - 8
Pneumatic Specifications	10 - 8
Pipeline Supply.....	10 - 8
Cylinder Supply	10 - 9
Auxiliary Common Gas Outlet (ACGO)	10 - 9
Anesthetic Vaporizer	10 - 9
Drive Gas.....	10 - 10
O ₂ Controls	10 - 10
Breathing System Specifications	10 - 10
Breathing System Volume.....	10 - 10
Volume Exchanger Volume	10 - 10
CO ₂ Absorber Assembly.....	10 - 10
Breathing System Connections.....	10 - 10
APL Valve	10 - 11
Resistance.....	10 - 12
Breathing System Temperature Controller.....	10 - 14
Breathing Circuit Parameters	10 - 14
Unidirectional Valve Opening Pressure.....	10 - 14
Anesthetic Gas Scavenging System (AGSS).....	10 - 14
Negative Pressure Suction device.....	10 - 14
Monitor Module.....	10 - 15
AG Module	10 - 15
Alarms	10 - 18
Effect of Interfering Gas on AG Measured Value	10 - 19
Monitor Mode.....	10 - 19
Oxygen Monitor Using Oxygen Cell	10 - 20
Alarms	10 - 20
Effect of Interfering Gas on Oxygen Cell Measured Value	10 - 20
Agent Usage Calculation and Agent Usage Speed.....	10 - 20
Ventilator Specifications.....	10 - 21
Displays and Controls Specifications	10 - 24
Electronic Controls.....	10 - 24
Pneumatic Controls	10 - 24
Alarms.....	10 - 25
Response Time of the Anesthesia System to an Increase in O ₂ Concentration (From 21% to 90%/100%).....	10 - 26
Accessories	A - 1
Parameters and Factory Defaults	B - 1
Spirometry Screen.....	B - 2
Limits.....	B - 2
Main Menu.....	B - 3

Screen Brightness.....	B - 5
Volume.....	B - 5
History.....	B - 6
Lung Recruitment.....	B - 6
Fresh Gas Control.....	B - 6
Patient Information.....	B - 6
Ventilation Mode.....	B - 7
Ventilation Linkage Parameters.....	B - 10
Constraints Among Ventilation Parameters.....	B - 14
Operating Principles.....	C - 1
Pneumatic Diagram.....	C - 2
Electric System Structure.....	C - 6
Abbreviations, Symbols, and Units of Measure.....	D - 1
Abbreviations.....	D - 2
Symbols.....	D - 3
Units of Measure.....	D - 3
Electromagnetic Compatibility.....	E - 1
Preparation for Malignant Hyperthermia Susceptible Patients.....	F - 1
Malignant Hyperthermia Causes, Effects and Treatment.....	F - 2
Malignant Hyperthermia Washout.....	F - 2
Washout Procedure for Malignant Hyperthermia Susceptible Patients with Anesthesia Delivery Systems.....	F - 2
References.....	F - 4

This page intentionally left blank.

Rx only: U.S. Federal Law restricts this device to sale by or on the order of a physician or other practitioner licensed by state law to use or order the use of this device.

Intellectual Property Statement

SHENZHEN MINDRAY BIO-MEDICAL ELECTRONICS CO., LTD. (hereinafter called Mindray) owns the intellectual property rights to this Mindray product and this manual. This manual may refer to information protected by copyright or patents and does not convey any license under the patent rights or copyright of Mindray, or of others.

Mindray intends to maintain the contents of this manual as confidential information. Disclosure of the information in this manual in any manner whatsoever without the written permission of Mindray is strictly forbidden. Release, amendment, reproduction, distribution, rental, adaptation, translation or any other derivative work of this manual in any manner whatsoever without the written permission of Mindray is strictly forbidden.

 **MINDRAY** are the trademarks, registered or otherwise, of Mindray in China and other countries. All other trademarks that appear in this manual are used only for informational or editorial purposes. They are the property of their respective owners.

This posting serves as notice under 35 U.S.C.§287(a). for Mindray patents: <http://www.mindrayna.com/patents>.

Responsibility on the Manufacturer Party

Contents of this manual are subject to change without prior notice.

All information contained in this manual is believed to be correct. Mindray shall not be liable for errors contained herein or for incidental or consequential damages in connection with the furnishing, performance, or use of this manual.

Mindray is responsible for the effects on safety, reliability and performance of this product, only if:

- all installation operations, expansions, changes, modifications and repairs of this product are conducted by Mindray authorized personnel;
- the electrical installation of the relevant room complies with the applicable national and local requirements; and
- the product is used in accordance with the instructions for use.

WARNING: It is important for the hospital or organization that employs this equipment to carry out a reasonable service/maintenance plan. Neglect of this may result in machine breakdown or personal injury.

NOTE: This equipment must be operated by skilled/trained clinical professionals.

Warranty

THIS WARRANTY IS EXCLUSIVE AND IS IN LIEU OF ALL OTHER WARRANTIES, EXPRESSED OR IMPLIED, INCLUDING WARRANTIES OF MERCHANTABILITY OR FITNESS FOR ANY PARTICULAR PURPOSE.

Exemptions

Mindray's obligation or liability under this warranty does not include any transportation or other charges or liability for direct, indirect or consequential damages or delay resulting from the improper use or application of the product or the use of parts or accessories not approved by Mindray or repairs by people other than Mindray authorized personnel.

This warranty shall not extend to:

- Malfunction or damage caused by improper use or man-made failure.
- Malfunction or damage caused by unstable or out-of-range power input.
- Malfunction or damage caused by force majeure such as fire and earthquake.
- Malfunction or damage caused by improper operation or repair by unqualified or unauthorized service people.
- Malfunction of the instrument or part whose serial number is not legible enough.
- Other malfunctions not caused by instrument or part itself.

Phone Numbers and How To Get Assistance

A network of service representatives and factory-trained distributors is available. Prior to requesting service, perform a complete operational check of the instrument to verify proper control settings. If operational problems continue to exist, contact the Service Department at 877.913.9663 (toll free) for Technical Support or 650.316.3199 (outside North America) for assistance in determining the nearest field service location.

Please include the instrument model number, the serial number (located on the back of the Anesthesia System), and a description of the problem with all requests for service.

Warranty questions should be directed to a local representative. A list of offices, along with their phone numbers, is provided at the end of this manual.

NOTE: **Upon request, calibration instructions or other information will be provided to assist the user's appropriately qualified technical personnel in repairing those parts of the Anesthesia System which are designated as repairable.**

Manufacturer and Address

Manufacturer: Shenzhen Mindray Bio-Medical Electronics Co., Ltd.
Address: Mindray Building, Keji 12th Road South, High-tech industrial park, Nanshan,
 Shenzhen 518057, P.R. China

Foreword

The Operator's Manual for the A9 Anesthesia System (herein referred to as Anesthesia System, Equipment, A9) contains the instructions necessary to operate the product safely and in accordance with its function and intended use. Observance of this manual is a prerequisite for proper product performance and correct operation and ensures patient and operator safety.

This manual is based on the maximum configuration and therefore some contents may not apply to your product. If you have any question, please contact us.

This manual is an integral part of the product. It should always be kept close to the equipment so that it can be obtained conveniently when needed.

Intended Audience

This manual is for clinical professionals who are expected to have a working knowledge of medical procedures, practices and terminology as required for monitoring of critically ill patients.

Illustrations

All illustrations in this manual serve as examples only. They may not necessarily reflect the setup or data displayed on your anesthesia system.

Responsibilities of Operators

The proper function of the Anesthesia System can only be guaranteed if it is operated and serviced in accordance with the information provided in this manual and by an authorized Mindray service representative. Non-compliance with this information voids all guarantee claims.

The Anesthesia System must be operated by qualified and trained personnel only. All operators must fully observe this operator's manual and relevant additional documentation. They must also comply with the WARNINGS, CAUTIONS, and NOTES detailed in this manual.

This page intentionally left blank.

1.0

Safety

Safety Information.....	1-2
Symbols	1-11

1.1 Safety Information

WARNING — Indicates a potential hazard or unsafe practice that, if not avoided, could result in death, serious injury or property damage to the patient or user.

CAUTION — Indicates a potential hazard or unsafe practice that, if not avoided, could result in minor personal injury, product malfunction, damage or property loss to the patient or user.

NOTE — Provides application tips or other useful information to ensure that you get the most from your product.

1.1.1 Warnings

WARNING: Do not operate the anesthesia system before reading this manual.

WARNING: All analog or digital equipment connected to this system must be certified passing the specified IEC standards (such as IEC 60950 for data processing equipment and IEC 60601-1 for medical electrical equipment). All configurations shall comply with the valid version of IEC 60601-1. The personnel who are responsible for connecting the optional equipment to the I/O signal port shall be responsible for medical system configuration and system compliance with IEC 60601-1.

WARNING: This equipment must only be operated by trained, skilled medical staff.

WARNING: Before putting the system into operation, the operator must verify that the equipment, connecting cables, and accessories are in correct working order and operating condition.

WARNING: The equipment must be connected to a properly installed power outlet with protective earth contacts only. If the installation does not provide for a protective earth conductor, disconnect it from the power line or operate from the equipment's internal battery supply.

WARNING: Multiple AC power outlets are provided on the rear of the equipment. These outlets are intended to supply power to additional equipment that form a part of the anesthesia system (i.e. vaporizers, etc.). Do not connect other equipment to these outlets, as patient leakage current may be affected. Each outlet is rated 3 A. The total current that may be drawn through all outlets is 5 A on the system. Do not attempt to exceed these load ratings. Do not connect additional Multiple Portable Socket Outlets (i.e. Multiple outlet extension cords) (MPSOs) or extension cords to these outlets.

WARNING: Do not place MPSOs on the floor.

WARNING: Connect the anesthesia system to an AC power source before the internal battery is depleted.

WARNING: Do not open the equipment housings. All servicing and future upgrades must be carried out only by trained and authorized Mindray personnel.

WARNING: Do not rely exclusively on the audible alarm system for patient monitoring.

WARNING: Adjustment of alarm volume to a low level may result in a hazard to the patient.

WARNING: Alarm settings should be customized according to different patient situations. Constantly keeping the patient under close surveillance is the most reliable way for safe patient monitoring.

-
- WARNING:** The physiological parameters and alarm messages displayed on the screen of the equipment are for the caregiver's reference only and cannot be directly used as the basis for clinical treatment.
- WARNING:** Dispose the packaging material, observing the applicable waste control regulations and keeping it out of children's reach.
- WARNING:** To avoid the possibility of explosion, do not use the equipment in the presence of flammable anesthetic agents, vapors or liquids. Do not use flammable anesthetic agents such as ether and cyclopropane for this equipment. Use only non-flammable anesthetic agents that meet the requirements specified in ISO 80601-2-13. The anesthesia system can be used with Isoflurane, Sevoflurane and Desflurane. Only one anesthetic agent can be used at a time.
- WARNING:** To avoid the risk of electric shock, this equipment must only be connected to a supply mains with protective earth.
- WARNING:** The use of anti-static or electrically conductive breathing tubes, when utilizing high frequency electric surgery equipment, may cause burns, and is therefore not recommended in any application of this equipment.
- WARNING:** Possible electric shock hazard. The equipment may only be opened by authorized service personnel.
- WARNING:** The patient should be visually monitored by qualified personnel. In certain situations, life-threatening circumstances may occur that may not necessarily trigger an alarm.
- WARNING:** Set the alarm limits properly based on the patient conditions so that the alarm is triggered before a hazardous situation occurs. Incorrectly set alarm limits may result in operating personnel not being aware of drastic changes in the patient's condition.
- WARNING:** Connection of both medical and non-medical equipment to the auxiliary mains socket outlet(s) may increase the leakage currents to values exceeding the allowable limits.
- WARNING:** Electric shock and fire hazard. Do not clean the equipment while it is powered on and/or plugged into an outlet.
- WARNING:** Disconnect the power plug from the mains supply before removing the rear panels or servicing the equipment.
- WARNING:** Malfunction of the central gas supply system may cause more than one or even all devices connected to it to stop their operation simultaneously.
- WARNING:** The anesthesia system will cease to deliver gas when the gas supply pressure is smaller than 200 kPa.
- WARNING:** Standard gas terminal connectors tailored to the attributes of gases should be used on the gas supply hose assembly to avoid damage to people and materials from improper connectors used.
- WARNING:** Use a cleaning and disinfection schedule that conforms to your institution's disinfection and risk-management policies.
- Refer to the material safety data sheet as applicable.
 - Refer to the operation and maintenance manuals of all disinfection equipment.
 - Do not inhale fumes produced during any disinfection process.

-
- WARNING:** Use extreme care while handling the CO₂ absorbent as it is a caustic irritant.
- WARNING:** Use care in lifting and manipulating vaporizers during the installing process as their weight may be greater than expected, based on their size and shape.
- WARNING:** Do not use talc, calcium stearate, corn starch or similar materials, as these materials may enter the patient's lungs or airway, causing irritation or injury.
- WARNING:** All gas supplies should be of medical grade.
- WARNING:** Single use breathing tubes, face masks, sensors, soda lime, water traps, sampling lines, airway adapters, and other single use items may be considered potential biologically hazardous items and should not be reused. Dispose of these items in accordance with hospital policy and local regulations for contaminated and biologically hazardous items.
- WARNING:** To avoid endangering the patient, do not perform test or maintenance when the equipment is in use.
- WARNING:** Review the performance specifications of the disposal system that the transferring and receiving systems are intended to be used with, to ensure compatibility.
- WARNING:** The equipment should not be used adjacent to or stacked with other equipment. If adjacent or stacked use is necessary, the equipment should be observed to verify normal operation in the configuration in which it will be used.
- WARNING:** Ensure that the current alarm presets are appropriate before use on each patient.
- WARNING:** A hazard can exist if different alarm presets are used for the same or similar equipment in any single area.
- WARNING:** Due to the size and weight of the equipment, it should only be moved by qualified personnel.
- WARNING:** Overloading machine may cause tipping. Equipment attached to the side of the equipment should be within the rated weights to prevent dumping of the machine.
- WARNING:** Excess load may cause a tip hazard while moving the equipment. Before moving, remove all equipment from the top shelf and all monitoring equipment installed to the side of the equipment. Use care when moving the equipment up or down a slope, around a corner, and across threshold. Do not attempt to roll the equipment over hoses, cords, or other obstacles.
- WARNING:** Leaks or internal venting of sampled gas may affect accuracy. Perform proper preoperative tests to ensure that the equipment is operating properly. Leaky circuits can not be used.
- WARNING:** Connecting the equipment's exhaust port to the hospital's waste gas scavenging system is strongly recommended to prevent exposure of hospital personnel to the waste gas.
- WARNING:** Pins of connectors identified with the ESD warning symbol should not be touched. Connections should not be made to these connectors unless ESD precautionary procedures are used.

-
- WARNING:** Operation of the equipment below the minimum flow values may cause inaccurate results.
- WARNING:** This equipment/system is intended for use by healthcare professionals only. This equipment/system may cause radio interference or may disrupt the operation of nearby equipment. It may be necessary to take mitigation measures, such as reorienting or relocating the equipment, or shielding the location it was placed.
- WARNING:** Ensure that an independent means of ventilation (e.g. a self-inflating manual resuscitator with mask) is available whenever the equipment is in use.
- WARNING:** The use of accessories with damaged packaging may cause biocontamination or failure. The operator should check the integrity of accessory packaging before use.
- WARNING:** Before using the anesthesia system after cleaning or disinfecting, power on the system and follow the on-screen prompts to perform leak test and compliance test. See (Pages 5-7) 5.4.2 "Leak & Compliance Test".
- WARNING:** If the equipment is damaged in any way that compromises the safety of the patient or user, discontinue use and attach a visible label indicating that the equipment is unusable. Please contact Mindray Technical Support.
- WARNING:** Oxygen, when present in high concentrations, can significantly increase the chance of fire or explosion. Oil and grease may be ignited at the same time. Therefore, oil and grease should not be used where oxygen enrichment may occur.
- WARNING:** Use of lubricants not recommended by Mindray may increase the danger of fire or explosion. Please use lubricants as approved by Mindray.
- WARNING:** Low-pressure regulators and flow-meters are susceptible to high pressure, and may burst if improperly maintained or disassembled while under pressure. Changing or disassembling connectors should be performed only by qualified personnel.
- WARNING:** Do not disassemble the low-pressure regulator, flow-metering device, or connector while under pressure. Sudden release of pressure may cause injury.
- WARNING:** Check the specifications of the Anesthetic Gas Scavenging System (AGSS) and the specifications of the anesthesia system to ensure compatibility and to prevent a mismatched processing system.
- WARNING:** Avoid connecting two or more hose assemblies in series as this may cause a loss of pressure and flow.
- WARNING:** A hazard may exist due to the use of improper connectors. Ensure all assemblies use the proper connectors.
- WARNING:** Avoid replacing a high-pressure flexible connection with one of lower nominal inlet pressure.
- WARNING:** Reusing breathing circuits or reusable accessories that are not disinfected may cause cross-contamination. Disinfect the breathing circuits and reusable accessories before use.
- WARNING:** Inspect all breathing system components carefully before each use. Ensure all components contain no obstructions or debris that can cause a potential hazard to the patient.

-
- WARNING:** Use breathing circuits and manual bags in accordance with ASTM F1208 and compatible with standard 22mm male conical fittings per ASTM specifications F1054.
- WARNING:** The mains plug is used to isolate the anesthesia system circuits electrically from the supply mains. Do not place the anesthesia system to a place where it is difficult to operate the plug.
- WARNING:** Do not touch the patient when connecting external devices via the I/O signal ports or replacing the oxygen cell to prevent patient leakage current from exceeding the requirements specified by the standard.
- WARNING:** If the Drive Gas Pressure Low alarm occurs when the gas supply pressure is greater than 200 kPa, contact your service personnel or Mindray.
- WARNING:** Make sure that CO₂ can be fully absorbed by the absorbent after the CO₂ absorbent is replaced or a CO₂ absorbent canister is installed.
- WARNING:** Before moving the anesthesia system, remove the objects from the top shelf and bracket to prevent the system from tilting.
- WARNING:** AGSS is not recommended to be used when the breathing tubes between the waste gas disposal system and AGSS get clogged, the extracted flow of the waste gas disposal system is deficient or the waste gas disposal system fails to work properly, as the waste gas in the AGSS may flow out to the atmosphere at a rate higher than 100 mL/min.
- WARNING:** According to international laws and regulations, the equipment is required to monitor the O₂ concentration when applied to patients. If the equipment you are using is not configured with this feature, please use a monitor compliant with the corresponding international standards for O₂ concentration monitoring. The gas sampling tube of the monitor should be connected to the Y-shaped three-way valve of the breathing system of the equipment.
- WARNING:** CO₂ concentration monitoring is recommended when the equipment is applied to patients. If the equipment you are using is not configured with this feature, please use a monitor compliant with the corresponding international standards for CO₂ concentration monitoring. The gas sampling tube of the monitor should be connected to the Y-shaped three-way valve of the breathing system of the equipment.
- WARNING:** The anesthesia system may lose its balance if it is tilted more than 10 degrees. Use extreme caution when moving or resting the equipment on slopes of over 10 degrees. Before moving, remove all equipment from the top shelf, all monitoring equipment mounted to the side of this machine, all brackets, cylinders, objects on the top self and worktable and in the drawers.
- WARNING:** No modification of this equipment is allowed.
- WARNING:** The service personnel must be properly qualified and thoroughly familiar with the operation of the equipment.
- WARNING:** External exhaust outlets of Anesthesia System shall not be located to place which has any electrical component.
- WARNING:** If the equipment/system is used in RFID environment, such as RFID marking belt, chest card, mobile RFID reader and door control system, it may be disrupted by the operation of nearby RFID equipment. It may be necessary to take mitigation measures, such as re-orienting or relocating the equipment/system away from RFID equipment.

1.1.2 Cautions

- CAUTION:** To ensure patient safety, use only parts and accessories specified in this manual.
- CAUTION:** At the end of its service life, the equipment, as well as its accessories, must be disposed of in compliance with the guidelines regulating the disposal of such products, and in accordance with local regulations for contaminated and biologically hazardous items.
- CAUTION:** Magnetic and electrical fields are capable of interfering with the proper performance of the equipment. Ensure that all external devices operating in the vicinity of the equipment comply with the relevant EMC requirements. Mobile phones, x-ray equipment, and MRI equipment are possible sources of interference as they may emit higher levels of electromagnetic radiation.
- CAUTION:** This system operates correctly at the electrical interference levels identified in this manual. Higher levels can cause nuisance alarms that may stop automatic ventilation. Be aware of false alarms caused by high-intensity electrical fields.
- CAUTION:** Perform the daily checks specified on the checklist. In case of a system fault, do not operate the system until the fault has been corrected.
- CAUTION:** Before starting the equipment, users must be familiar with the information contained in this Operator's Manual and must have been trained by an authorized representative.
- CAUTION:** If the equipment does not function as described, it must be examined and repaired as necessary by qualified service personnel before being put back to use.
- CAUTION:** Handle the equipment with care to prevent damage or functional faults.
- CAUTION:** Ensure that the gas supply of the equipment always complies with the technical specifications.
- CAUTION:** Before clinical use, the equipment must be correctly calibrated and/or the respective tests must be performed, as described in this Operator's Manual.
- CAUTION:** If system faults occur during the initial calibration or testing, the equipment should not be operated until those faults have been corrected by a qualified service personnel.
- CAUTION:** After servicing, functional, sensor, and system tests must be performed before clinical use.
- CAUTION:** Each time you replace the vaporizer, please carry out leak test for the breathing circuit.
- CAUTION:** Use cleaning agent sparingly. Excess fluid could enter the equipment and cause damage.
- CAUTION:** Do not autoclave any parts of the equipment unless specifically identified as autoclavable in this manual. Clean the equipment only as specified in this manual.
- CAUTION:** To prevent system damage:

- Refer to the documentations provided by the manufacturer of the cleaning agent.
- Never use organic, halogenated or petroleum-based solvents, anesthetic agents, glass cleaning agents, acetone or other irritant agents.
- Never use abrasive agents (i.e. steel wool or silver polish) to clean components.
- Keep all liquids away from electronic components.
- Prevent liquid from entering the equipment.
- All cleaning solutions used must have a pH value between 7.0 and 10.5.

- CAUTION:** Never immerse the oxygen sensor or its connector into any type of liquid. Dispose the O₂ sensor according to the manufacturer's specifications.
- CAUTION:** Do not fumigate using peracetic acid or formaldehyde.
- CAUTION:** The valve disc in each of the inhalation and exhalation valve assemblies on the breathing system is fragile and must be handled with care while disassembling the valve cage from the valve assembly.
- CAUTION:** Only connect Mindray approved devices to the equipment's communication ports. Devices connected to the ethernet ports must comply with IEC 60950.
- CAUTION:** Do not connect any non-isolated devices to the DB9/RS232C interface of the equipment.
- CAUTION:** Do not connect any devices to the SB ports other than Mindray approved USB storage devices and a supported USB mouse.
- CAUTION:** Do not wash the inner surface of the oxygen sensor.
- CAUTION:** Do not perform soaking or high-temperature processing on the O₂ sensor.
- CAUTION:** Users should monitor oxygen percentage (FiO₂%) when using the Auxiliary O₂/Air Flow Meters. Without oxygen monitoring, it would be impossible to know the concentration of oxygen delivered to the patient.
- CAUTION:** The equipment is NOT suitable for use in a magnetic resonance imaging (MRI) environment.
- CAUTION:** To ensure measurement accuracy and to avoid possible damage to the equipment, use only Mindray-approved cables and accessories.
- CAUTION:** Use the power cord provided with the product. If a substitute is necessary, use power cord in compliance with the specification.
- CAUTION:** Do not use a damaged device or accessory. Periodically check all cables (e.g., AC line cord and patient connection cables) for damage that may occur through normal use. Replace cables if damaged in any way.
- CAUTION:** Use of other oxygen sensors may cause improper oximeter performance.
- CAUTION:** Unintended movement may occur if the casters are not locked. The operator should lock casters during use of the equipment.
- CAUTION:** Unsecured devices may slide off the top shelf. Devices should be securely attached to the top shelf.

- CAUTION:** The voltage on the auxiliary outlets should be the same voltage as the outlet into which the equipment is plugged. Ensure that devices plugged into the auxiliary outlets are rated for the same supply voltage as the equipment.
- CAUTION:** Do not use any flow outlets as handles when moving the equipment. The flow outlets may become damaged. Use the metal side bars on the main body when moving the equipment.
- CAUTION:** Do not push down on the bag arm forcefully or hang heavy objects onto it. Excessive weight may bend and damage the bag arm.
- CAUTION:** Use caution when disconnecting [quick connectors], as the sudden release of pressure may cause injury.
- CAUTION:** Avoid factors that can contribute to deterioration of the hose assemblies. Factors include excessive bending, crushing, abrasion, system pressures and temperatures that exceed hose ratings, and improper installation.
- CAUTION:** Be careful in lifting and manipulating the breathing system during disassembly of the system.
- CAUTION:** When the electronic flow control system is disabled, the backup flow control system will be enabled. The initial flow of backup flow control system is 1 L/min of O₂. The backup flow control system display only has a total flowmeter which can display a maximum flow of 15 L/min.
- CAUTION:** Turn the flow control knob of the backup flow control system slowly. To avoid damaging the control valves, do not turn further when the flowmeter reading is out of range. When turning a flow control knob clockwise to decrease flow, the flowmeter should reach 1 L/min before the knob reaches its most clockwise mechanical stop (off) position. Do not turn any further when the knob has reached the off position. Turning a flow control knob counter clockwise increases flow.
- CAUTION:** Prevent or avoid using and storing the gas supply hose assembly in an environment exposed to ultraviolet light or oxidizing agents, or in a high-temperature or moist environment to avoid damage to people and materials because of the release of pressure from aged hoses in the assembly.

1.1.3 Notes















- NOTE:** Figures in this manual are provided for reference purposes only. Screens may differ based on the system configuration and selected parameters.
- NOTE:** Put the equipment in a location where you can easily see the screen and access the operating controls.
- NOTE:** Keep this manual close to the equipment so that it can be obtained conveniently when needed.
- NOTE:** The software was developed in compliance with IEC 60601-1. The possibility of hazards arising from software errors is minimized.
- NOTE:** This manual describes all features and options. Your equipment may not have all of them.
- NOTE:** The equipment is intended to be operated with its integral Breathing Pressure monitoring in use.













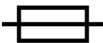





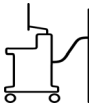

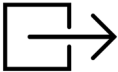
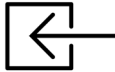
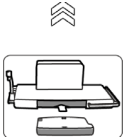
-
- NOTE:** The equipment is intended to be operated with its integral Breathing Pressure limiting devices in use.
- NOTE:** The equipment is intended to be operated with its integral Expiratory Volume monitoring in use.
- NOTE:** The equipment is intended to be operated with its integral Breathing System integrity Alarm System in use.
- NOTE:** The equipment is intended to be operated with its integral Continuous Pressure Alarm in use.
- NOTE:** The equipment is intended to be operated with its integral O₂ monitoring in use.
- NOTE:** An Anesthesia Vapor Delivery Device is to be used with an Anesthetic Agent Monitor complying with ISO 80601-2-55. The connection of Patient Circuit and Agent monitor should be made by a sample line.
- NOTE:** Continuously monitor the anesthetic agent concentration when using the anesthesia system to ensure accurate output of the anesthetic agent.
- NOTE:** Check the liquid level of the anesthetic agent before and during all operations. When the liquid level is below the warning line, more anesthetic agent needs to be added.
- NOTE:** The system is designed to be equipped with an anesthetic vapor delivery device that complies with ISO 80601-2-13.
- NOTE:** The battery supply of this equipment is not a user serviceable component. Only an authorized service representative can replace the battery supply. If the system is not used for a long time, contact a service representative to have the battery supply disconnected. The disposal of battery should comply with local regulations. At the end of the battery life, dispose of the battery supply in accordance with local regulations.
- NOTE:** Areas designated for the servicing of oxygen equipment shall be clean, free of oil and grease, and not be used for the repair of other equipment.
- NOTE:** Opening the cylinder valve quickly may cause unexpected pressure difference and lead to potential fire or explosion hazard due to the oxygen pressure shock. Open and close the cylinder valve slowly.
- NOTE:** Changes in inlet pressure, outlet resistance, or ambient temperature may affect the accuracy of flow values.
- NOTE:** The power supplies, terminal units and pipeline systems can be supplied by one or several different manufacturers.
- NOTE:** Regional or national regulations that apply to manufacturers of medical equipment can exist.
- NOTE:** The product does not contain latex parts.
- NOTE:** The operator should stay right in front of the equipment within four meters away from the display to facilitate observation of the displayed information on the equipment.
- NOTE:** Some alarm settings on this equipment are not configurable by users.
- NOTE:** The tidal volume and minute ventilation displayed on this equipment are measured in BTPS conditions. The fresh gas flow is measured in STPD conditions.



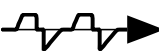











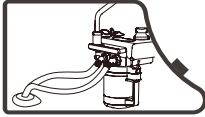

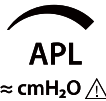

- NOTE:** For the method of connecting this equipment to an external monitor or other devices, please see Anesthesia System Bracket Installation Instructions.
- NOTE:** All the materials of this equipment exposed to gases are compatible with O₂, air and N₂O.
- NOTE:** To avoid abnormal gas supply, the anesthesia system has a 758 kPa pressure relief valve installed at the gas supply inlet. When the gas supply pressure is abnormally elevated, the pressure relief valve is turned on to ensure the proper operation of the anesthesia system. When the pressure relief valve is on, the anesthesia system and the O₂ flush are both operating properly, and their P-F (pressure/flow) characteristics are consistent with those under rated conditions. The pressure at the high-pressure O₂ outlet will be elevated to 758 kPa, and the maximum flow rate meets requirements in the specifications.
- NOTE:** The defibrillation restoration time is 15 seconds unless otherwise stipulated.
- NOTE:** If the O₂ Flush button is pressed for a long time, the concentration of anesthetic in the breathing system will drop too fast, which may trigger the vaporizer abnormal concentration alarm.

1.2 Symbols

The following table provides descriptions of symbols that are used on the equipment and/or within this manual.

SYMBOL	DESCRIPTION	SYMBOL	DESCRIPTION
	Caution!		Warnings
	Temperature limitation		Humidity limitation
	Keep dry		Atmospheric pressure limitation
	This way up		Fragile, handle with care
	Recyclable		Stacking limit by number
	Ambient: temperature range		Ambient: humidity range
	Electrical: alternating current (AC)		Electrical: internal battery

	Electrical: equipotentiality		Electrical: protective earth (ground)
	Electrical: fuse or circuit breaker		Video signal port
	Electrical: powered-on		Electrical: powered-off
	Electrical: input/output		Gas flow: flow control knob
	Pipelined gas supply		Gas cylinder
	Gas Outlet		Gas Inlet
MAX	Maximum value	MIN	Minimum value
>PPSU<	Material: polyethylene sulfone (PPSU)	>PSU<	Material: polysulfone
	Assemble volume exchanger		Disassemble O ₂ sensor
O₂%	O ₂ Sensor Connector	O₂⁺	Gas: O ₂ flush button
	Lock/Unlock: locked		Lock/Unlock: unlocked
	Manual ventilation		Automatic ventilation
	Water Drain		Watertrap
	No heavy objects: Do Not Crush		Do Not Oil
134°C	Autoclavable		Not Autoclavable

	Caution: Hot		Direction
	Electrical: light	 5 kg MAX 11 lbs MAX	Weight limit
	ACGO mode		Automatic ventilation mode
	Filter Access		APL valve
	Canister opened		Canister closed
	Negative pressure suction device		Negative pressure gas supply
	Identifier: manufacturer's reference/catalog number		Identifier: serial number
IPX1	Protection level of anesthesia system against splashing water		Applied parts of defibrillator proof type BF equipment
	Identifier: Manufacturer		Refer to instruction manual/booklet
	MR Unsafe - keep away from magnetic resonance imaging (MRI) equipment		
ETL CLASSIFIED  Intertek 3179617	Conforms to AAMI Std. ES 60601-1, IEC Std.60601- 1-6, IEC Std.60601- 1-8, ISO Std. 80601-2-13, ISO Std. 80601-2-55. Certified to CSA Std. C22.2 NO. 60601-1, NO.60601-1-6, NO.60601-1-8, NO.60601-2-10, NO.80601-2-13, NO.60601-2-26, NO.80601-2-55.		
	Electrical: WEEE (Waste of Electrical and Electronic Equipment) Marking. Separate treatment from general waste at end of life.		
Rx Only	U.S. Federal Law restricts this device to sale by or on the order of a physician or other practitioner licensed by state law to use or order the use of this device.		



Battery is fully charged. AC power is connected and it is powering the system.



Battery is partially charged. AC power is connected. It is charging the battery and powering the system.



Battery is fully charged and it is powering the system. AC power is not connected.

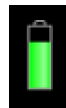

Battery is partially charged and it is powering the system. AC power is not connected.



Battery level is low and it is powering the system. Recharging recommended. AC power is not connected.



Battery is not installed



Alarm Audio Off icon



Alarm Audio Pause icon



Alarm Off icon



Low priority message



Medium priority message



High priority message

2.0

Product Description

Introduction	2-2
Equipment Views.....	2-4

2.1 Introduction

2.1.1 Indications For Use

The Anesthesia System is a device used to administer to a patient, continuously or intermittently, a general inhalation anesthetic and to maintain a patient's ventilation.

The Anesthesia System is intended for use by licensed clinicians in the administration of general anesthesia, for patients requiring anesthesia within a health care facility, and can be used in adult, pediatric and neonate populations.

High Flow Nasal Cannula (HFNC) is indicated for delivery of nasal high flow oxygen to spontaneously breathing adult patients. It can be used for pre-oxygenation and short-term supplemental oxygenation (up to 10 minutes) during intubation in operating rooms. It is not intended for apneic ventilation. HFNC is indicated for use in adults only.

WARNING: This anesthesia system is intended for use by qualified anesthesia personnel only or under their guidance. Personnel for using the equipment should receive complete pre-use training. Unauthorized personnel, or personnel who have received no training, must not perform any operations on the equipment.

WARNING: The equipment is not suitable for use in an MRI environment.

2.1.2 Structure and Composition

The Anesthesia System consists of main unit, anesthetic ventilator, anesthetic gas delivery system, anesthetic vaporizer (V90 model, applicable anesthetic agents: Isoflurane, Sevoflurane and Desflurane), anesthetic breathing system (including the airway pressure gauge, volume exchanger, CO₂ absorbent canister, inspiratory and expiratory check valves, inspiratory and expiratory flow sensors, exhaust valves, Auto/Manual switch, manual bag port, inspiratory and expiratory ports and connectors), Anesthetic Gas Scavenging System (AGSS), negative pressure suction device, anesthetic gas monitoring module, O₂ cell and accessories.

2.1.3 Functions and Features

The anesthesia system is intended to provide continuous or intermittent general inhalation anesthesia and maintain ventilation for patients. This equipment also provides ventilation monitoring for patients. The anesthesia system is applicable to patient environments.

Applied parts of the anesthesia system are the breathing tubes and masks. Connect the patient to the Anesthesia System via the breathing circuit. The anesthesia system provides the following ventilation modes:

- **Manual ventilation**
- **Volume Control Ventilation (VCV)**
- **Pressure Controlled Ventilation**
 - Pressure Controlled Ventilation (PCV)
 - Pressure Controlled Ventilation-Volume Guarantee (PCV-VG)
- **Synchronized Intermittent Mandatory Ventilation (SIMV)**
 - Synchronized Intermittent Mandatory Ventilation – Volume Control (SIMV-VC)
 - Synchronized Intermittent Mandatory Ventilation – Pressure Control (SIMV-PC)
 - Synchronized Intermittent Mandatory Ventilation – Volume Guarantee (SIMV-VG)
- **Continuous Positive Airway Pressure/Pressure Support Ventilation (CPAP/PS)**
- **Airway Pressure Release Ventilation (APRV) (optional)**

The anesthesia system provides the following frequently-used features or configurations:

- Cardiopulmonary bypass
- Monitor mode
- Lung Recruitment (optional)
- High-flow Nasal Cannula Oxygen (HFNC)
- Flow pause
- Anesthetic breathing system purge
- Agent usage calculation
- Anesthetic gas monitoring (with paramagnetic O₂ sensor)
- Oxygen concentration monitoring
- Screen saver
- AGSS visualization
- Auxiliary Common Gas Outlet (ACGO)
- Sample gas return to the anesthesia breathing system
- Negative pressure suction
- External auxiliary worktable

2.2 Equipment Views

2.2.1 Main Unit (Front View)

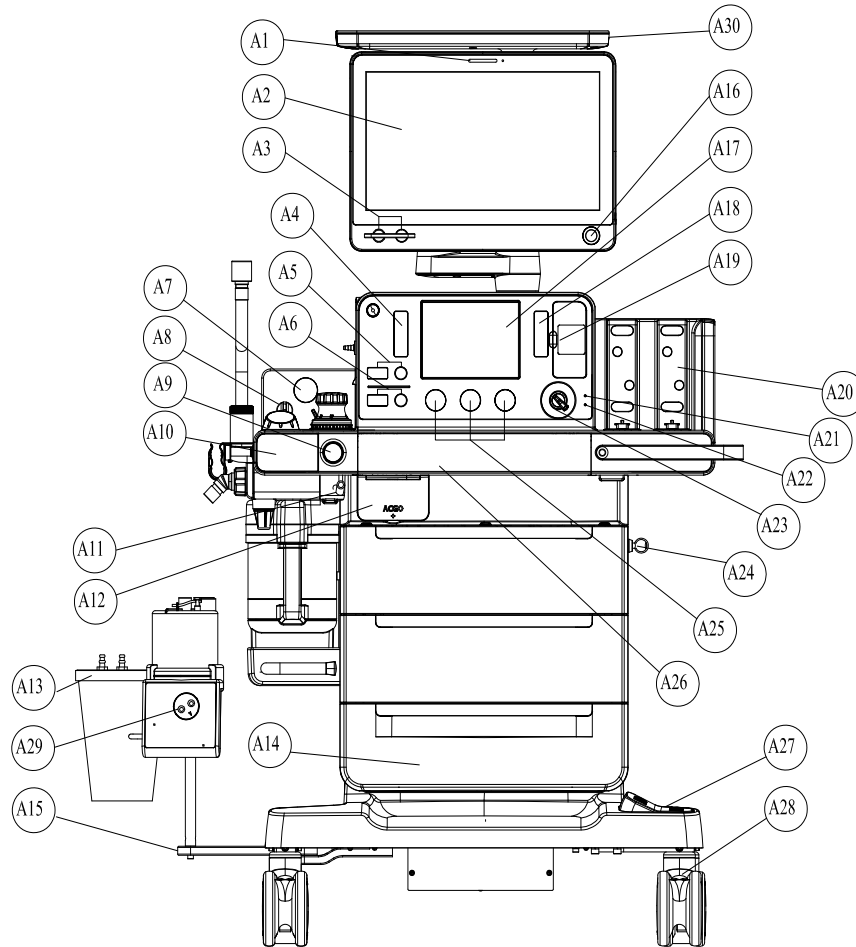

Figure 2-1 Main Unit (Front View)

PARTS	DESCRIPTION
A1 Alarm LED	The alarm LED may turn red, yellow or cyan, indicating different priorities. Red = high priority, yellow = medium priority, cyan = low priority, off = no alarms.
A2 Main Screen	See "System Interface" on Pages 4-1.
A3 The flow or O₂ concentration control knob of the electronic flow control system.	Rotate the knob to adjust the flow or O ₂ concentration.

PARTS		DESCRIPTION
A4	High-flow Nasal Cannula Oxygen (HFNC)	There is a float in the flow tube, and the scale line that the middle of the float is aligned to indicates the current gas flow. There is a flow control knob on the flowmeter to control the flow. Rotate the knob counter clockwise to increase the gas flow and rotate the knob clockwise to reduce the gas flow.
A5	Total flow control knob for HFNC	Rotate the knob to adjust the total flow of the HFNC.
A6	Oxygen concentration control knob for HFNC	Rotate the knob to adjust the O ₂ concentration of the HFNC.
A7	Negative pressure gauge	Used to indicate the negative pressure.
A8	Negative pressure suction switch	Used to switch the work mode of the negative pressure suction device. FULL, OFF and REG modes are available. FULL mode indicates that the negative pressure suction device works with the maximum pressure continuously and the control knob is inoperative. OFF mode indicates that the negative pressure is turned off and the negative pressure suction device is inactive. REG mode indicates that the pressure of the negative pressure suction device can be adjusted with the negative pressure control knob. Rotate the knob counter clockwise to increase the negative pressure. Rotate the knob clockwise to reduce the negative pressure.
A9	O₂ Flush button	Used to provide high-flow O ₂ for the inspiratory branch of the breathing system.
A10	Oxygen sensor cover	Open the cover to install the O ₂ sensor.
A11	Negative pressure suction tube clamp	Used to retain the tubes of the negative pressure suction device.
A12	ACGO (independent outlet and switch)	ACGO switch is used to enable/disable the ACGO feature. ACGO independent outlet is used to output fresh gas.
A13	Negative pressure suction liquid collection bottle	Used to collect the hydrops, hemothorax, pus and other contaminants from the patient's pharynx.
A14	Storage drawers	Three (3) storage drawers (lockable) are available.
A15	Liquid collection bottle and humidifier bracket	Used to support the negative pressure suction liquid collection bottle and humidifier.
A16	Main control knob of display	Press the main control knob to select an item on the menu or confirm the settings. Rotate the knob clockwise or counter clockwise to scroll the items on the menu or change the settings.
A17	Status display	Used to display the status of gas supply pressure, volume exchanger, AGSS, electronic anesthetic vaporizer and heating module of the breathing system.
A18	Total flowmeter of Backup Flow Control System	Display the total flow of Backup Flow Control System.
A19	Backup Flow Control System (BFCS) Cover	Pull the BFCS cover switch outward to start the BFCS. Rotate the flow control knob to control the air and O ₂ flows. Rotate the knob counter clockwise to increase the gas flow and rotate the knob clockwise to reduce the gas flow.
A20	Vaporizer Mount Spot	Used to install and lock the vaporizer. Two vaporizers are supported.
A21	Battery charging indicator	The indicator is on when the battery is being charged.
A22	AC status indicator	The indicator is on when the system is connected to an AC power source.
A23	System switch	Used to switch on or off the system.

PARTS	DESCRIPTION
A24 Key lock	The key and lock to lock a drawer.
A25 Gas supply pressure gauge	Used to indicate the pressure of the O ₂ , air and N ₂ O backup gas cylinders for the anesthesia system.
A26 Volume exchanger cover	Pull the unlocking button in the bottom right corner outward as per instructions on the equipment to open the volume exchanger cover.
A27 Caster lock	Lock/release the brakes for front two casters when depressed.
A28 Caster	The system moves with the help of casters. Caster lock of the equipment is controlled by the central brake and caster brake.
A29 Humidifier	The humidifier should be connected to the tube when the High-flow Nasal Cannula Oxygen (HFNC) feature is enabled.
A30 Top Shelf	Top shelf surface.

2.2.2 Main Unit (Rear View)

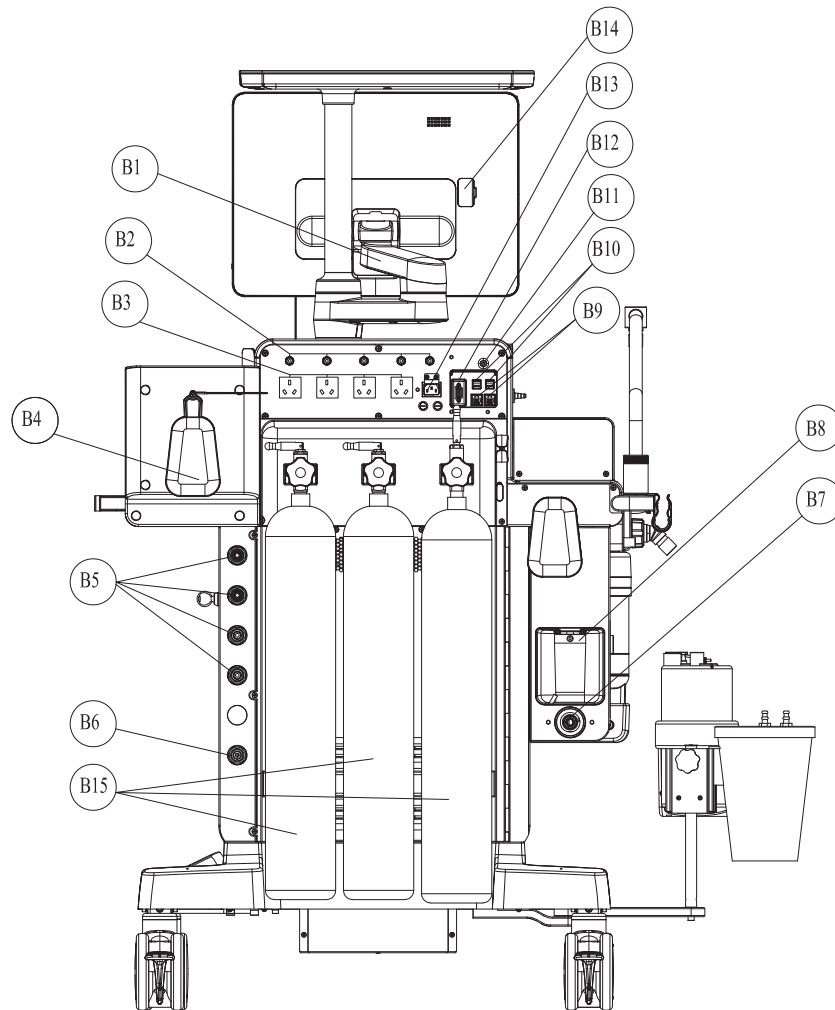

Figure 2-2 Main Unit (Rear View)

PARTS	DESCRIPTION
B1 Display arm	Used to install the display.
B2 Breaker	The breaker for each auxiliary output power outlet.
B3 Auxiliary AC power outlet	Four auxiliary AC power outlets are available.
B4 Hanger	Used to hang cables and gas supply hoses.
B5 Pipelined gas supply ports	The connecting ports for pipelined gas supply of O ₂ , air and N ₂ O.

PARTS		DESCRIPTION
B6	Negative pressure source port	Used to connect to the wall-mounted negative pressure source of the hospital.
B7	Waste Gas Scavenging outlet	Used to connect to the waste gas disposal system. NOTE: Please use a waste gas disposal system that complies with the ISO 80601-2-13 standard.
B8	Overfill protection	The overfill protection of the negative pressure suction device, used to prevent backflow of effluent after the bottle is full to ensure pipeline and tube safety.
B9	Network interfaces (CS1, CS2)	Used to connect to other equipment with network cables.
B10	SB interfaces (SB1, SB2, SB3, SB4)	Used to connect to a USB device. CAUTION: Do not connect any devices to the SB ports other than Mindray approved USB storage devices and a supported USB mouse.
B11	Equipotentiality	Used to provide a grounding point. Used to eliminate the electric potential difference between the ground wires of different devices to ensure safety.
B12	Communication interface (SP1)	RS232 communication interface.
B13	Power input socket	Used to connect to the power cord.
B14	Video signal port	Used to connect to an external display.
B15	Cylinders	Supply tanks containing high pressure O ₂ , Air, and N ₂ O to act as backup supply if the pipeline pressure is removed.

2.2.3 Main Unit (Left View)

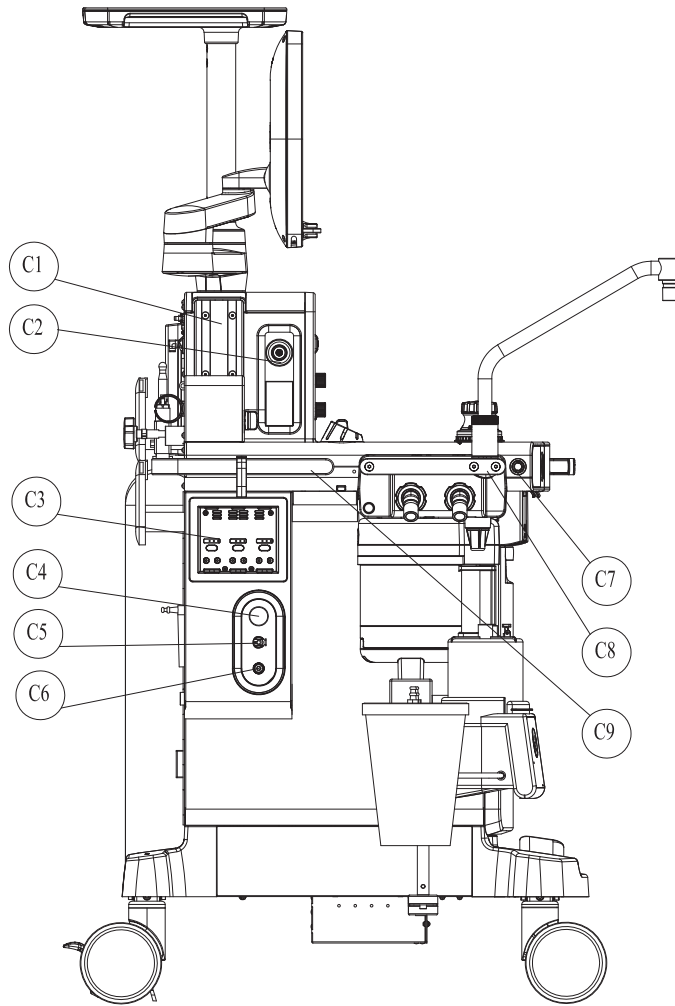

Figure 2-3 Main Unit (Left View)

PARTS		DESCRIPTION
C1	Installing rail	Used to install the standard attachment arms of the monitor and other equipment. Installing rails are available on both sides of the equipment.
C2	High-flow Nasal Cannula Oxygen (HFNC) outlet	Used to output O ₂ when the High-flow Nasal Cannula Oxygen (HFNC) feature is enabled.
C3	Module slot	Used to be inserted with and recognize the AG module mentioned in this manual.
C4	AGSS flow control knob	Rotate the knob clockwise or counter clockwise to adjust the flow in the AGSS until the float in the Status Screen is located between Min and Max scale lines.
C5	Sample gas return port	The sample gas return port of the Gas module.
C6	Auxiliary high-pressure O₂ outlet	Used to connect to an external device (such as an air-jet ventilator) for hyperbaric O ₂ venting.
C7	Oxygen sensor cover switch	Used to open the O ₂ sensor cover.
C8	Handle	The maximum force capacity of the handle is 10 kgf (22 lbf). WARNING: The handle is intended to be used for installing and disassembling the breathing system only and shall not be used for pushing/pulling/lifting the anesthesia system.
C9	Handle	The handle is intended to be used for pushing/pulling/rotating the anesthesia system, with a maximum force capacity of 80 kgf (176 lbf).

2.2.4 Main Unit (Right View)

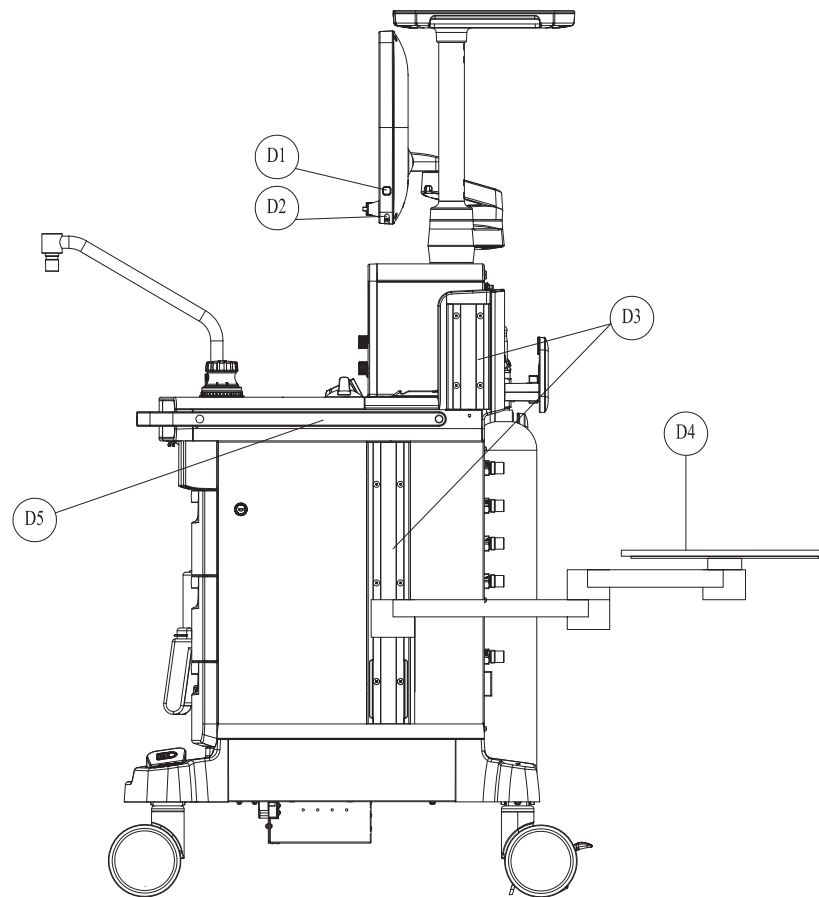

Figure 2-4 Main Unit (Right View)

PARTS	DESCRIPTION
D1 Work lamp switch	Used to turn on/off the work lamp. Three settings are available: off, low-light and high-light. Users can only turn on the work lamp when the system is switched on.
D2 Work lamp	Located beneath the display to illuminate the worktable.
D3 Installing rail	Used to install the standard attachment arms of the monitor and other equipment.
D4 External auxiliary worktable (optional)	External auxiliary worktable, 180-degree rotatable horizontally. Maximum supporting weight: 15kg (33 lbs).
D5 Handle	The handle is intended to be used for pushing/pulling/rotating the anesthesia system, with a maximum force capacity 80 kgf (176 lbf).

2.2.5 Main Unit (Top View)

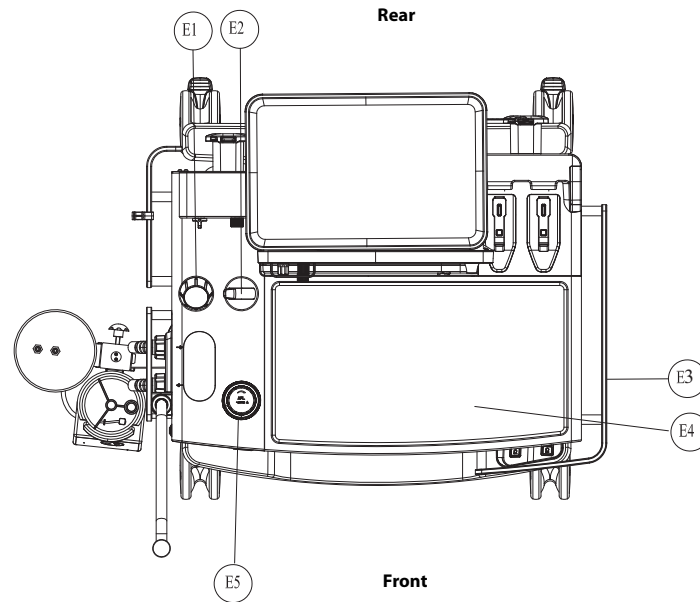

Figure 2-5 Main Unit (Top View)

PARTS		DESCRIPTION
E1	Airway pressure gauge¹	Used to indicate the airway pressure of patients.
		NOTE: It is normal to have a minor difference between the airway pressure gauge reading and the electronically monitored value. When the difference is greater than 15%, please contact your service personnel or Mindray.
E2	Manual/Auto switch	Used to switch between the automatic ventilation and manual ventilation modes.
E3	Handle	The handle is intended to be used for pushing/pulling/rotating the anesthesia system, with a maximum force capacity 80 kgf (176 lbf).
E4	Workbench	Workbench surface (stainless steel), with a maximum force capacity of 30 kgf (66 lbf).

PARTS	DESCRIPTION
E5 APL valve¹	Used to set the rotary pressure regulating valve of the breathing system during manual ventilation. Its scales represent the approximate pressure values. Set the APL valve to the SP position during spontaneous respiration. Elevate the APL valve upward as needed to release the pressure quickly. At a flow of 3L/min, the pressure of the APL valve should be between 1cmH ₂ O and 3cmH ₂ O (exclusive) either in dry or humid conditions. At a flow of 30L/min, the pressure of the APL valve should be between 1cmH ₂ O and 5cmH ₂ O (exclusive) either in dry or humid conditions.

¹ The APL valve and PAW gauge numerics are for reference only. Calibrated patient airway pressure is displayed on the user screen.

2.2.6 Breathing System

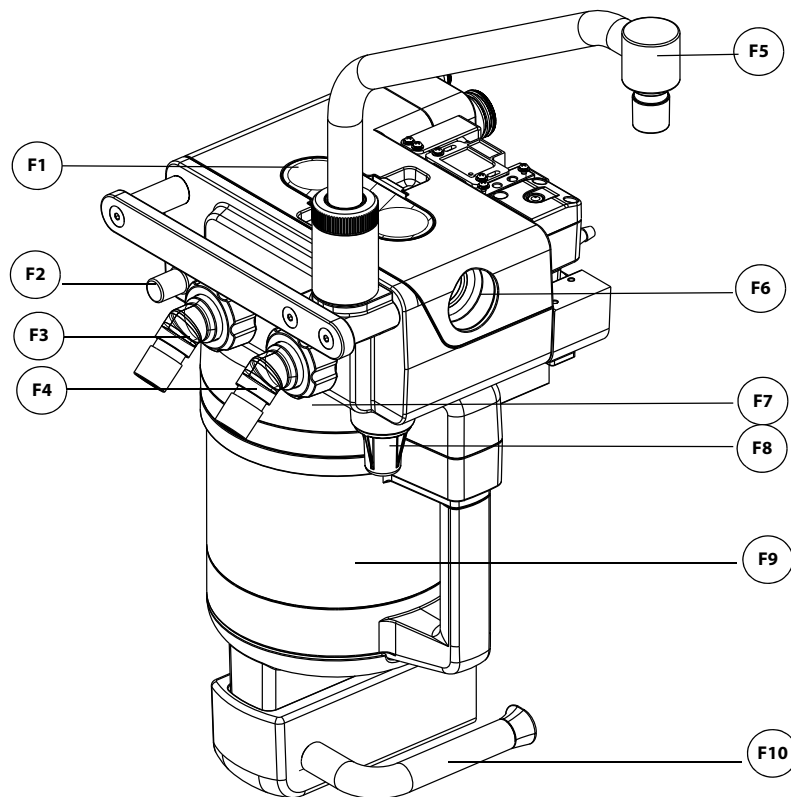

Figure 2-6 Breathing System

PARTS	DESCRIPTION
F1 Observation window of expiratory/inspiratory check valve	Used to observe the status of expiratory and inspiratory check valves from outside the equipment.
F2 Leak test plug	Used to connect to a breathing tube for leak tests.

PARTS	DESCRIPTION
F3 Expiration connector	The expiration connector of the breathing circuit.
F4 Inspiration connector	The inspiration connector of the breathing circuit.
F5 Bag arm	Used to connect to a manual ventilation bag.
F6 O₂ sensor port	Used to install the O ₂ sensor to monitor the O ₂ concentration.
F7 Canister bypass assembly	Used to maintain the pressure in the breathing circuit when the soda lime in the CO ₂ absorbent canister is being replaced.
F8 Watertrap	Used to collect the condensate water in the breathing system. The watertrap must be emptied on a regular basis.
F9 CO₂ absorbent canister	The container for holding the CO ₂ absorbent (bulk CO ₂ absorbent or Pre-pak CO ₂ absorbent).
F10 Canister lock	A latch to lock (horizontal)/unlock (vertical) the canister.

2.2.7 Negative Pressure Suction Device



Figure 2-7 Negative pressure suction device

PARTS	DESCRIPTION
G1 Overfill Protection	Prevents the fully collected waste liquid from flowing backward to ensure the tubing safety.
G2 Negative pressure gauge	Indicates negative pressure value.
G3 Negative pressure adjustment knob	Adjusts the pressure of negative pressure suction device.
G4 Selector switch	Switches over between the working modes of the negative pressure suction device. It can be set to FULL, OFF, or REG. FULL indicates that the negative pressure suction device is working with the maximum pressure continuously that is taken from the wall and the adjustment knob does not function. OFF indicates that the negative pressure suction device is turned off and is not working. REG indicates that the negative pressure suction device works with the pressure adjusted through the negative pressure adjustment knob. Turn the knob counterclockwise to increase negative pressure and clockwise to decrease the negative pressure.

Installation and Disassembly

Unpacking.....	3-3
Initial Setup.....	3-3
Breathing System.....	3-3
Vaporizer	3-4
Negative Pressure Suction Device	3-8
High-flow Nasal Cannula Oxygen (HFNC) Tube.....	3-10
Anesthetic Gas Scavenging System (AGSS)	3-11
Connect Anesthesia System with Information System.....	3-14
Connect Anesthesia System to Patient Monitor	3-15
Connect Anesthesia System with eGateway.....	3-15

- WARNING:** Before installation, check the adequacy of the surface of the structure to which the equipment is to be attached.
- WARNING:** This equipment must be installed by a factory authorized representative.
- WARNING:** Continuous use of desiccated soda lime may endanger patient safety. Adequate precautions should be taken to ensure that the soda lime in the CO₂ absorbent canister does not become desiccated. Turn off all gases when finished using the system.
- WARNING:** When electrosurgical equipment is used, keep the electrosurgical leads away from the breathing system, the O₂ sensor, and other parts of the anesthesia system. Keep available backup manual ventilation and a respirator with mask in case the electrosurgical equipment prevents safe use of the ventilator. Ensure the correct operations of all life support and monitoring equipment.
- WARNING:** Do not use masks or breathing tubes that are antistatic or conductive. They can cause burns if they are used near high frequency electrosurgical equipment.
- WARNING:** This anesthesia system has waste gas exhaust ports. The operator of the machine should pay attention to the disposal of the residual breathing gas scavenged.
- CAUTION:** The operational environment and the power source of the equipment must comply with the requirements as specified in the "Product Specifications" on Pages 10-1.

3.1 Unpacking

When the anesthesia system is delivered, IMMEDIATELY inspect the box for any damage.

- a. If there is NO damage and ALL tip indicators on the box exterior are intact, then sign and date the bill of lading or airway bill to indicate safe receipt of the equipment.
- b. If there is DAMAGE or ANY of the tip indicators on the box exterior have been activated, then conditionally accept the delivery and clearly describe the damages on the bill of lading or airway bill. BOTH the carrier and recipient must sign and date the bill of lading or airway bill. Save all damaged factory packaging until further instructed by Mindray. The receiver should immediately contact Mindray Customer Service.

3.2 Initial Setup

The initial setup of the anesthesia system must be performed by an authorized Mindray service representative. Please contact Mindray Technical Support for any additional assistance.

3.3 Breathing System

Please install the breathing system, refer to 9.7.3.4 "Reassembly".

3.4 Vaporizer

The equipment contains a 2-position vaporizer system to enable anesthetic agents to be introduced into the fresh gas flow. Two vaporizers are supported, but only one vaporizer can be used at a time. Isoflurane, Desflurane and Sevoflurane vaporizers can be used.

NOTE: **The barometric pressure may differ from the calibration pressure of the anesthetic vaporizer. This may cause an inaccurate output of the anesthetic agent. The operator should continuously monitor the concentration of anesthetic agent during system use to determine if the output concentration is accurate.**

1. To install a vaporizer, hold the vaporizer handle and press the button on the handle, then push the vaporizer in along the vaporizer rail.



Figure 3-1 Vaporizer

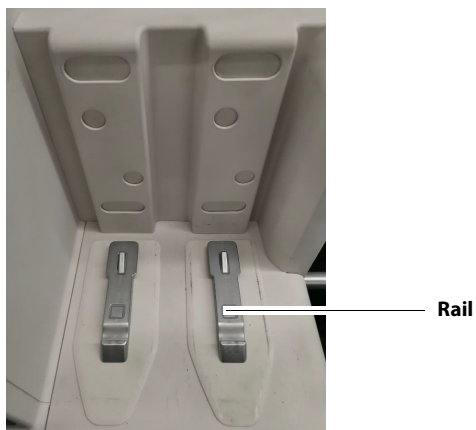

Figure 3-2 Vaporizer rail

2. You will hear a snap when the vaporizer is installed in place. If the anesthesia system is in standby or running status, the status indicator of the vaporizer will flash green and then go off. Or the indicator may flash yellow or red according to the vaporizer status.

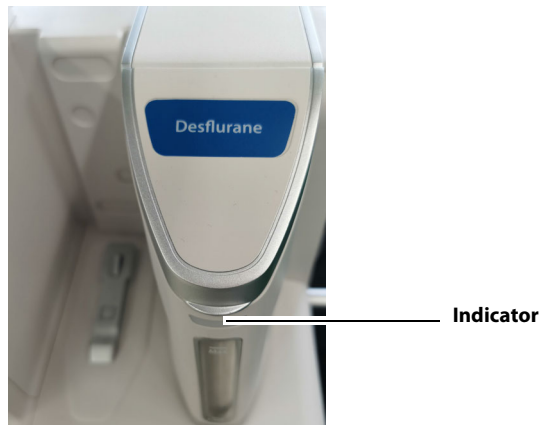

Figure 3-3 Vaporizer Indicator

3. To remove the vaporizer, keep the vaporizer in the inactive mode by setting the concentration to 0. Press the button on the handle, then pull the vaporizer out along the vaporizer rail.

3.4.1 Filling the Anesthetic Agent

The vaporizer can be filled either when installed on the anesthesia system or when not connected to the main unit. Filling methods for both approaches are the same.

The anesthetic agent liquid level can be observed in the glass-tube liquid-level meter of the vaporizer, or monitored on the display of the main unit. If the liquid level of the vaporizer is low, the main unit will prompt message alerts; if the liquid level of the vaporizer is close to being empty, the main unit will prompt alarms.

Use the correct filling adapter to fill the vaporizer. See the following for details:

ANESTHETIC AGENT	FILLING ADAPTER
Isoflurane	Mindray safety filling adapter
Sevoflurane	Quik-Fil, Mindray safety filling adapter
Desflurane	Saf-T-fil

WARNING: The filling adapter should be matched with the anesthetic agent bottle and vaporizer type.

CAUTION: The vaporizer can be refilled during use however the vaporizer will stop delivering anesthetic agent when the vaporizer cover is open.

The anesthetic agent is filled to the Isoflurane and Sevoflurane vaporizers per the following steps:

1. Open the anesthetic agent bottle, and install the filling adapter matching the anesthetic agent.
2. Open the vaporizer cover, insert the anesthetic agent bottle to the vaporizer filling hole and press the bottle downward. Press hard on the anesthetic agent bottle to activate the self-sealing system of the vaporizer so that fluid in the bottle flows into the vaporizer.
3. After filling is complete, pull out the anesthetic agent bottle.
4. Close the vaporizer cover.

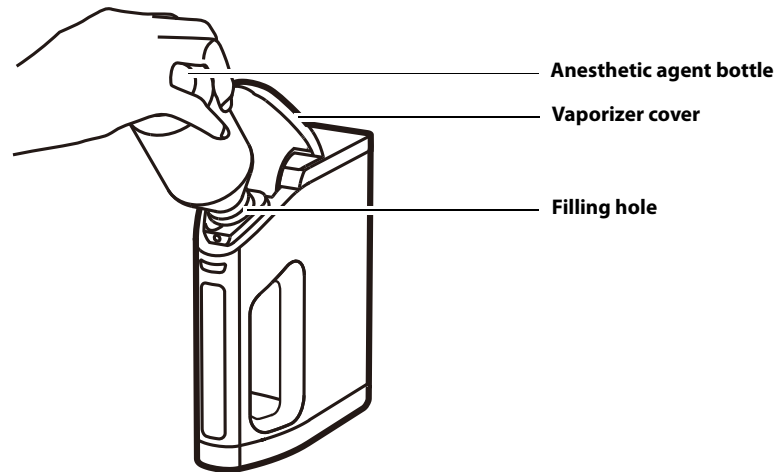

Figure 3-4 Fill the anesthetic agent (Isoflurane and Sevoflurane)

The anesthetic agent is filled to the Desflurane vaporizer per the following steps:

1. Open the Desflurane bottle.
2. Open the vaporizer cover and insert the anesthetic agent bottle to the vaporizer filling hole. You will hear a snap when the bottle is locked in place to the vaporizer, and the bottle cannot be pulled out. Press hard on the anesthetic agent bottle to activate the self-sealing system of the vaporizer so that fluid in the bottle flows into the vaporizer.
3. After filling is complete, stop pressing the anesthetic agent bottle. Hold the bottle with one hand and press the unlocking cover plate with the other hand to unlock the bottle from the vaporizer. Then pull out the bottle.
4. Close the vaporizer cover.

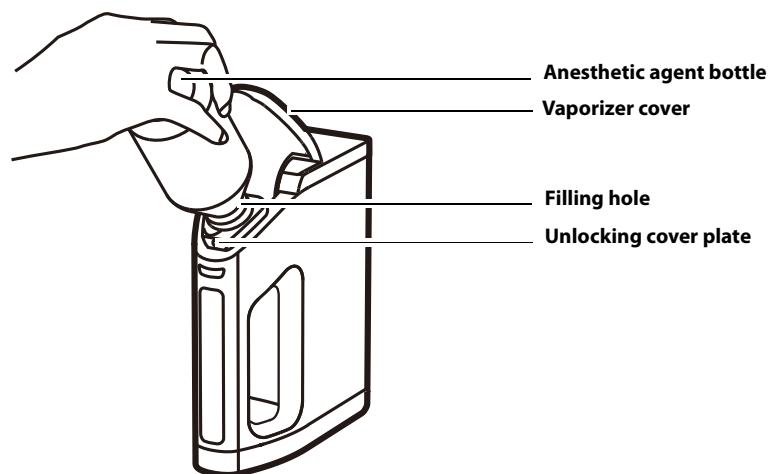

Figure 3-5 Fill the anesthetic agent (Desflurane)

WARNING: Ensure that the correct anesthetic agent is used. The vaporizer is designed with the specific anesthetic agent named on it and further indicated by color coded labeling. The actual output concentration of the anesthetic agent will vary if the vaporizer is filled with the wrong agent.

3.4.2 Draining the Anesthetic Agent

It is recommended that the anesthetic agent in the reservoir of the vaporizer be drained before long-haul transport or long-term storage of the vaporizer.

The anesthetic agent is drained from the Isoflurane and Sevoflurane vaporizers per the following steps:

1. Connect the anesthetic agent bottle with its matched filler.
2. Insert the anesthetic agent bottle to the matched vaporizer filling hole.
3. Place the vaporizer upside down then press the vaporizer downward to activate the self-sealing system of the vaporizer so that the agent fluid in the vaporizer flows back to the bottle.
4. Place the vaporizer horizontally again after the anesthetic agent is fully removed.
5. Pull out the anesthetic agent bottle.

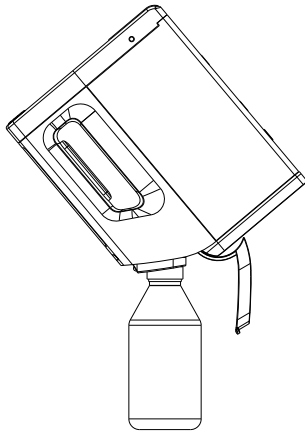

Figure 3-6 Draining the anesthetic agent (Isoflurane and Sevoflurane)

The anesthetic agent is drained from the Desflurane vaporizer per the following steps:

1. Insert the anesthetic agent bottle to the matched vaporizer filling hole. You will hear a snap when the bottle is locked in place to the vaporizer, and the bottle cannot be pulled out.
2. Place the vaporizer upside down then press the vaporizer downward to activate the self-sealing system of the vaporizer so that the agent fluid in the vaporizer flows back to the bottle.
3. Place the vaporizer horizontally again after the anesthetic agent is fully removed.
4. Hold the bottle with one hand and press the unlocking cover plate with the other hand to unlock the bottle from the vaporizer pull out the bottle.

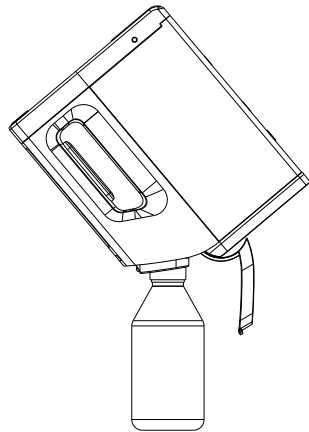

Figure 3-7 Draining the anesthetic agent (Desflurane)

WARNING: The anesthetic liquid drained from the vaporizer must not be used again. Please regard it as a dangerous chemical and dispose of it properly in accordance with local regulations.

3.5 Negative Pressure Suction Device

The negative pressure suction device comprises the negative pressure regulator, the liquid collection bottle, the suction tube and the filter. It is primarily used to collect the hydrops, hemothorax, pus and other contaminants from the patient's pharynx. The unit supports overfill protection to prevent backflow of effluent after the bottle is full to ensure pipeline and tube safety.

1. Place the liquid collection bottle to the bracket. Connect the suction tube, the liquid collection bottle and the filter following the screen printed instructions.
2. Insert the suction tube to the overfill protection connector. The negative pressure suction device is now fully installed.

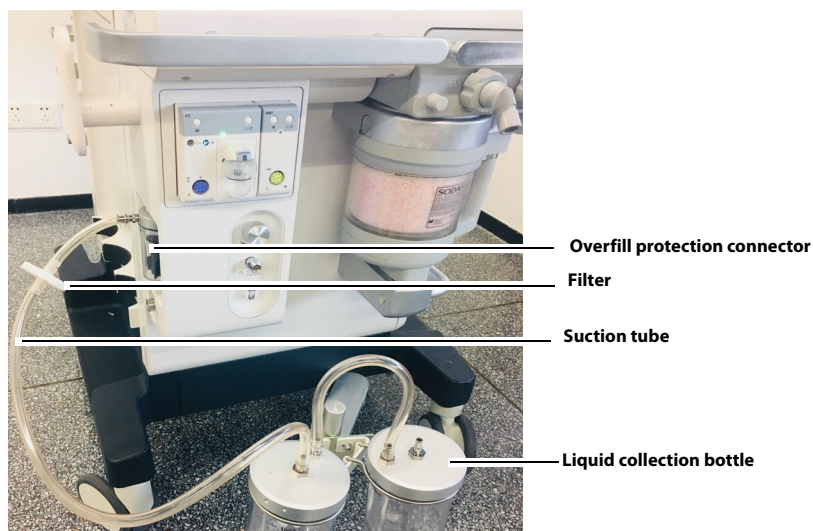

Figure 3-8 Install the negative pressure suction device

NOTE: When installing the filter to the suction tube, pay attention to keeping the side printed with **IN** facing the liquid collection bottle.

NOTE: Avoid twisting or bending suction tubes during use.

3. To disassemble the negative pressure suction device, pull out the suction tube, take out the liquid collection bottle and discard the filter. To replace the filter, please follow local regulations to dispose of discarded filters.

3.5.1 Turn on Negative Pressure Suction Device

1. Assemble the negative pressure suction device.
2. Occlude the suction tube inlet at the patient end.
3. Turn on the negative pressure pipeline supply.
4. Set the selector switch to **REG**.
5. Adjust the negative pressure regulating knob to keep the pressure gauge reading smaller than -40kPa.

3.5.2 Turn off Negative Pressure Suction Device

Set the selector switch to **OFF** to turn off the negative pressure suction device.

WARNING: Keep the negative pressure suction switch in the **OFF** state when the negative pressure suction device is not in use.

3.6 High-flow Nasal Cannula Oxygen (HFNC) Tube

1. Hang the humidifier on the bracket on the side of the anesthesia system.

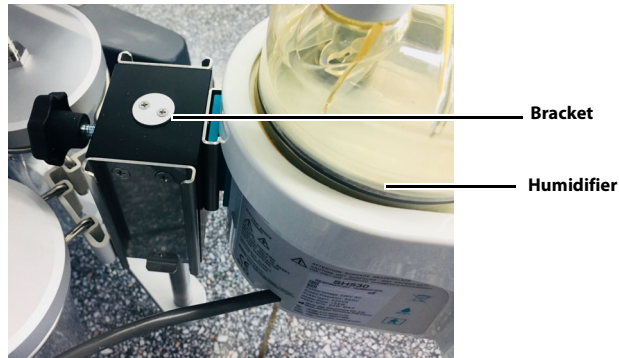

Figure 3-9 Install the humidifier

2. Connect the gas inlet of the humidifier and the HFNC outlet of the anesthesia system with a breathing tube. Connect the gas outlet of the humidifier and the patient with a breathing tube.

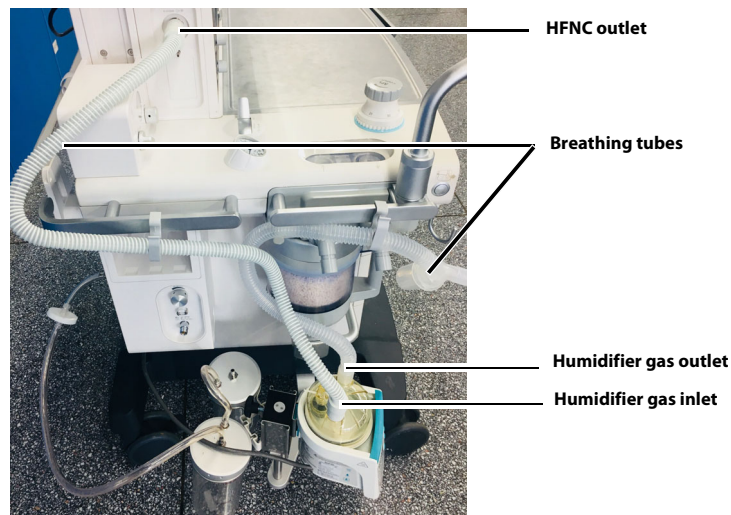

Figure 3-10 Connection hoses

3. To disassemble the humidifier, draw out the breathing tube and lift the humidifier upward.

3.7 Anesthetic Gas Scavenging System (AGSS)

3.7.1 Active AGSS

- When the ACGO circuit needs to scavenge the gas to the AGSS, connect the AGSS port with the ACGO as shown below.

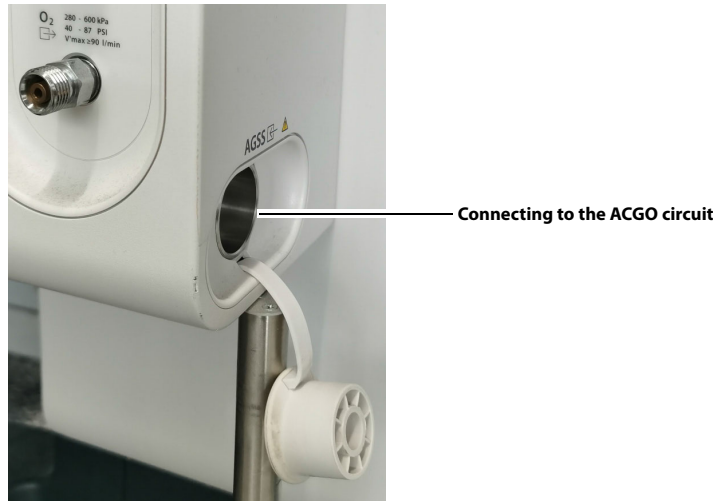

Figure 3-11 Active AGSS (connecting to the ACGO circuit)

- When the gas path of the patient monitor does not meet the biological compatibility standard, the patient monitor needs to scavenge the waste gas to the AGSS. Use the adapter as shown below.

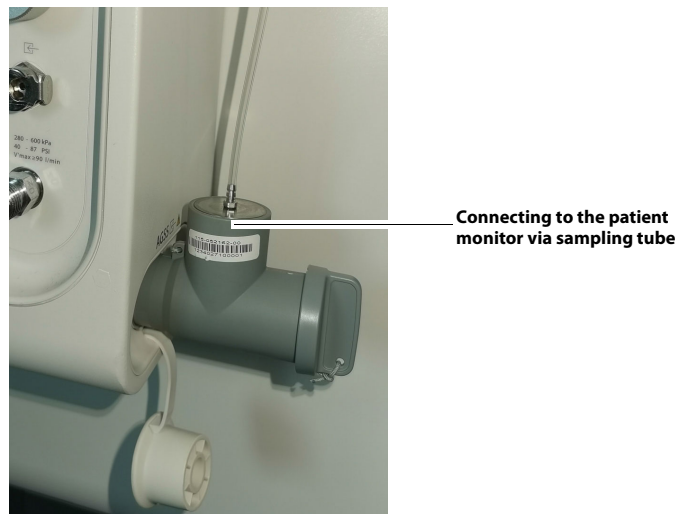

Figure 3-12 Active AGSS (connecting to the patient monitor)

- When both the patient monitor and ACGO circuit need to scavenge the gas to the AGSS, use the adapter as shown below.

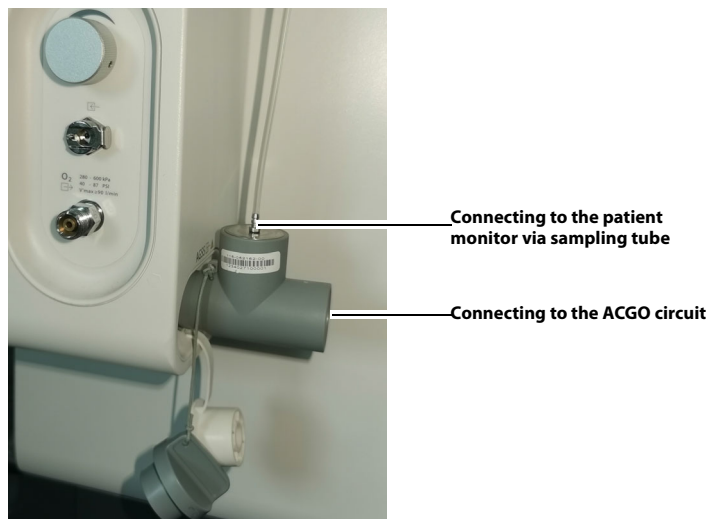

Figure 3-13 Active AGSS (connecting to the patient monitor and ACGO circuit)

3.7.2 Passive AGSS

- When the ACGO circuit needs to scavenge the gas to the AGSS, use the adapter as shown below.

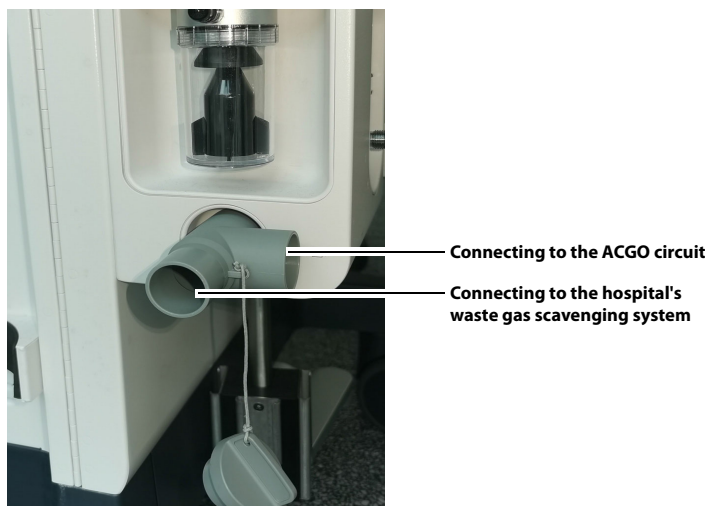

Figure 3-14 Passive AGSS (connecting to the ACGO circuit)

- When the gas path of the patient monitor does not meet the biological compatibility standard, the patient monitor needs to scavenge the waste gas to the AGSS. Use the adapter as shown below.

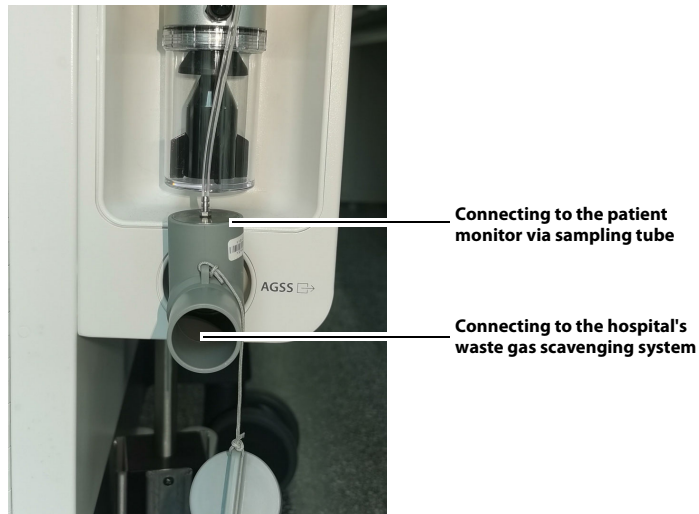

Figure 3-15 Passive AGSS (connecting to the patient monitor)

- When both the patient monitor and ACGO circuit need to scavenge the gas to the AGSS, use two adapters (one adapter as Figure 3-14 and one adapter as Figure 3-15) as shown below.

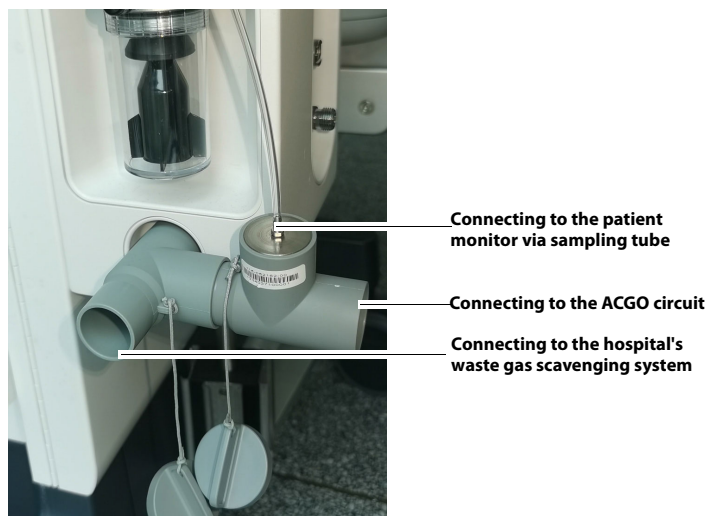



Figure 3-16 Passive AGSS (connecting to the patient monitor and ACGO circuit)

3.8 Connect Anesthesia System with Information System

3.8.1 Connect Anesthesia System with Information System Through Serial Interface

The anesthesia system can be connected to the information system through a serial interface and send its ventilation modes, status, parameters, alarms, alarm limits and patient information to the information system by the HL7 protocol.

1. The communication cable is connected to the communication interface of the anesthesia system on one end and connected to the matched interface of the information system on the other end.
2. Select the  icon to open the **[Setup]** menu.
3. Select the **[System]** soft key, enter the system password and confirm the password.
4. Select the **[Network]** tab in the system menu.
5. Select the **[Serial]** tab.
6. Set **[Protocol]** to **[HL7]**.
7. Configure related settings. See 4.7.8.4 (Pages 4-42) "Network".

3.8.2 Connect Anesthesia System with Information System Through Ethernet

The anesthesia system can be connected to the information system through ethernet and send its ventilation modes, status, parameters, alarms, alarm limits, patient information and waveforms to the information system by the HL7 protocol.

1. The network cable is connected to the ethernet interface of the anesthesia system on one end and connected to the matched interface of the information system on the other end.
2. Select the  icon to open the **[Setup]** menu.
3. Select the **[System]** soft key, enter the system password and confirm the password.
4. Select the **[Network]** tab in the system menu.
5. Select the **[HL7]** tab.
6. Configure related settings. See 4.7.8.4 (Pages 4-42) "Network".

NOTE: **The IP addresses of the anesthesia system and the information system must be in the same segment.**

3.9 Connect Anesthesia System to Patient Monitor

3.9.1 Connect Anesthesia System to Patient Monitor Through Serial Interface

The anesthesia system can be connected to a Mindray patient monitor through a serial interface and the BeneLink module to send the ventilation modes, parameters, alarms, alarm limits, waveforms and patient information to the patient monitor via the MR-WATO protocol.

The anesthesia system can be connected to the Philips patient monitor through a serial interface and the IntelliBridge module to send the partial ventilation modes, parameters, alarms, alarm limits and waveforms of the anesthesia system to the Philips patient monitor via the Philips IntelliBridge protocol.

1. The communication cable is connected to the communication interface of the anesthesia system on one end and connected to the matched interface of the monitor on the other end.
2. Select the  icon to open the **[Setup]** menu.
3. Select the **[System]** soft key, enter the system password and confirm the password.
4. Select the **[Network]** tab in the system menu.
5. Select the **[Serial]** tab.
6. Set **[Protocol]** to **[MR-WATO]** or **[Philips]**.
7. Configure related settings. See 4.7.8.4 (Pages 4-42) "Network".

3.10 Connect Anesthesia System with eGateway

The anesthesia system can be connected to the ADT server through eGateway to download patient information from the ADT server. See 4.2.1.2 (Pages 4-5) "Retrieve Patient Information from ADT Server".

With the anesthesia system connected to the eGateway, when key words are entered in the anesthesia system and eGateway recognizes the patient information related to the key words, it will update the patient information to the anesthesia system synchronously. If the patient information in the eGateway is updated, eGateway will also update the information to the anesthesia system synchronously. See 4.2.1.3 (Pages 4-5) "Synchronize Patient Information".

This page intentionally left blank.

System Interface

Main Screen.....	4-2
System Information Title.....	4-3
Fresh Gas Flow Display.....	4-10
Waveform/Parameter/Spirometry/Trend Display Zone.....	4-15
Ventilation Mode Tabs.....	4-23
System Soft Key.....	4-23
Setup Menu.....	4-28
Status Screen.....	4-46

4.1 Main Screen

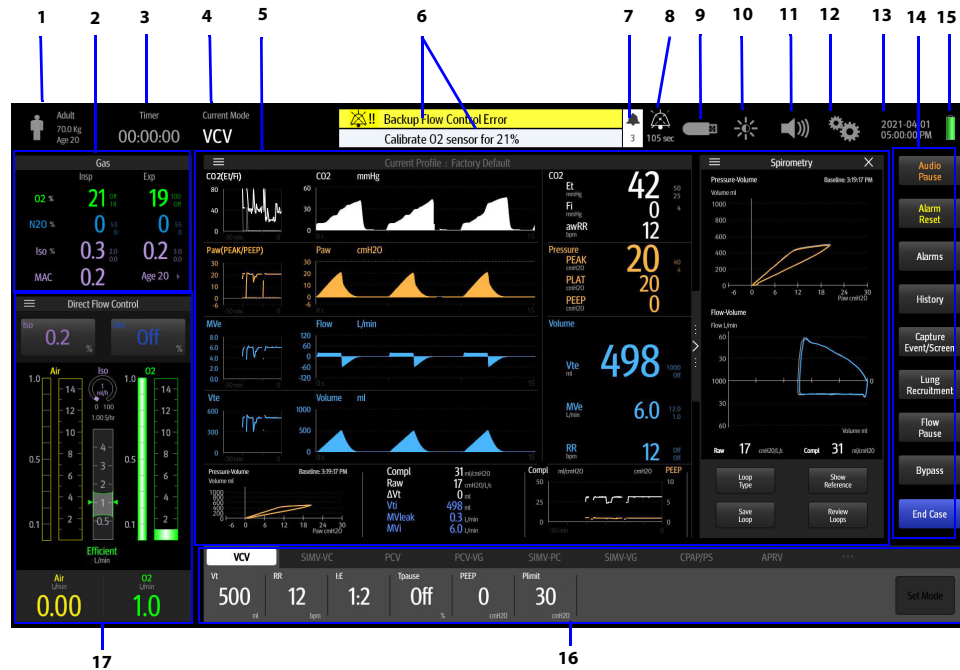

Figure 4-1 Main Screen

SERIAL NO.	MAIN SCREEN	DESCRIPTION
1	Patient information	Shows the information of the current patient, including the patient type, weight and age. You can click on the section to view more personal information of the patient. See (Pages 4-3) 4.2.1 "Patient Information".
2	Gas Area	The section displays parameter information in real time when the Gas or O ₂ Sensor module is configured.
3	Elapsed / Countdown Timer	Displays elapsed time. Select to start, stop, or reset the timer.
4	Current ventilation mode	Displays the current ventilation mode.
5	Waveform/parameter/spirometry/trend display zone	Displays the waveforms, monitoring parameters, spirometry, trends.

Table 4-1 Main Screen

SERIAL NO.	MAIN SCREEN	DESCRIPTION
6	Alarm/prompt message zone	<p>Displays physiological alarms, technical alarms and prompt messages. The most recent and top-priority alarm is displayed in the topmost section.</p> <p>Other alarms are displayed in the lower section, grouped by priority for scrolled display. Select the zone to display a list of all active alarms.</p> <p>See the table in Section "Alarms and Prompt Messages" on Pages 8-12 for a list of prompt messages and related priorities. Alarms with a high priority are displayed in red. Alarms with a medium priority are displayed in yellow. Alarms with a low priority are displayed in cyan. Prompt messages are displayed in white.</p>
7	Number of active alarms	Displays the current numbers of active alarms and prompts.
8	Audio Pause/Alarm Reset icon	When the [Audio Pause] or [Alarm Reset] soft key is selected, the Audio Pause or Alarm Reset icon is displayed along with a 120-second countdown timer.
9	U disk icon	The U disk icon is displayed when the anesthesia system recognizes that U disk is connected to the anesthesia system.
10	Screen brightness adjustment icon	Select the icon to adjust the brightness of both the Main Screen or Status Screen.
11	Volume adjustment icon	Select the icon to adjust the alarm volume, the system alert volume, the key click volume.
12	Setup icon	Select the icon to open the [Setup] menu.
13	System date and time	Displays the current system date and time. To adjust the date and time, see "Date and Time" on Pages 4-8.
14	Soft key field	Displays the [History] soft key, the [Lung Recruitment] soft key, the [Flow Pause] soft key, the [Capture Event/Screen] soft key, the [Alarms] soft key, the [Alarm Reset] soft key, the [Audio Pause] soft key, the [Bypass] soft key or the [Start Case] soft key. See (Pages 4-23) 4.6 "System Soft Key".
15	Main power supply and battery status icon	Displays the main power supply and battery status, See Pages 4-9 "Battery Status"
16	Ventilation mode and settings parameter zone	Displays tabs for ventilation modes. Each tab displays the ventilation mode and its parameters. Select a tab and the [Set Mode] soft key to change the ventilation mode. Select the parameter key to change the parameter settings. See "Set Ventilation" on Pages 6-5.
17	Display zone of fresh gas control/vaporizer/anesthetic agent consumption speed	<p>Displays the real-time flow and OPTIMIZER® information of O₂ or balance gas. Select the soft key zone to set the fresh gas flow in the pop-up menu.</p> <p>Displays the gas concentration of the vaporizer.</p> <p>Displays the anesthetic agent consumption speed and cost.</p>

Table 4-1 Main Screen

4.2 System Information Title

4.2.1 Patient Information

An icon displaying the information of the current patient. Select the icon to open the **Patient Information** menu. You can set the data for patients and hospitals in the Patient Information menu.



Figure 4-2 Patient information icon

Figure 4-3 Patient Information menu

NOTE: The equipment saves the latest patient parameter settings for each patient type: Adult, Pediatric, and Neonate. Changing to another patient size does not clear the parameter settings for the previous patient size. For example, changing from Adult to Pediatric and back to Adult will result in the Adult patient parameter settings still being saved.

EDITABLE FIELD	DESCRIPTION
Patient ID	
Visit Number	Enter up to 30 digits for each field. The fields will be cleared when the equipment powers off or enters the standby mode.
First Name	
Last Name	
Size	Radio option.
Gender	Radio option.
Height	
Age	Enter information using the virtual keyboard. The system will display prompt messages if the entered information exceeds the allowed range. The system will display <1 if the entered age is younger than 1.
Weight	
IBW	

Table 4-2 Patient information

EDITABLE FIELD	DESCRIPTION
Bed	Enter up to 30 digits for each field.
Room	
Department	
Facility	

Table 4-2 Patient information



4.2.1.1 Set Patient Information in Anesthesia System

NOTE: The patient type can be changed only when the equipment is in the standby or manual mode.

1. Select the Patient Information icon to open the Patient Information settings menu.
2. Set the patient information.
3. Select  to confirm the change and close the menu.

4.2.1.2 Retrieve Patient Information from ADT Server



The anesthesia system can be connected to the ADT server through eGateway to download patient information from the ADT server.

1. Connect the network cable.
2. Set the network and ensure that the network access is normal.
 - a. Enter Standby mode.
 - b. Select the  icon to open the **[Setup]** menu.
 - c. Select the **[System]** soft key, enter the system password and confirm the password.
 - d. Select the **[Network]** tab in the system menu.
 - e. Select **[ADT]** and set the **[ADT]** to  (on) on the pop-up screen.
 - f. Set **[Destination IP]** and **[Port]**.
 - g. Select the **[Test]** soft key.
 - h. Confirm that the test result is **[Connected]**.
3. Select the **[Find Patient]** soft key in the Patient Information menu.
4. Enter the key information on the pop-up screen.
5. Select the **[Search]** soft key and a list of conforming patient information will be displayed on the screen.
6. Select the desired patient information in the list and select the **[Import]** soft key. The imported data includes patient ID, visit number, first name, last name, bed, room, department and facility.

4.2.1.3 Synchronize Patient Information

With the anesthesia system connected to the eGateway, when key words are entered in the anesthesia system and eGateway recognizes the patient information related to the key words, it will update the patient information to the anesthesia system synchronously. If the patient information in the eGateway is updated, eGateway will also update the information to the anesthesia system synchronously. Synchronizable patient information include: patient ID, visit number, last name, first name, date of birth, age, weight, height and gender.

1. Connect the network cable.

2. Set the network and ensure that the network access is normal.
 - a. Enter Standby mode.
 - b. Select the  icon to open the **[Setup]** menu.
 - c. Select the **[System]** soft key, enter the system password and confirm the password.
 - d. Select the **[Network]** tab in the system menu.
 - e. Select **[MD2]** and set the **[MD2]** to  (on) in the pop-up screen.
 - f. Set **[Destination IP]** and **[Port]**.
 - g. Select the **[Test]** soft key.
 - h. Confirm that the test result is **[Connected]**.

NOTE: Key information is defined by the eGateway. For specific operations, see the eGateway Integrated Management and Installation Guide.

4.2.2 Timer (Elapsed Timer/Countdown Timer)

Displays the elapsed timer, the countdown timer or both of the two timers. The timer is located in the top left corner of the Main Screen. You can select the Timer icon to open the timer menu. (Figure 4-4)

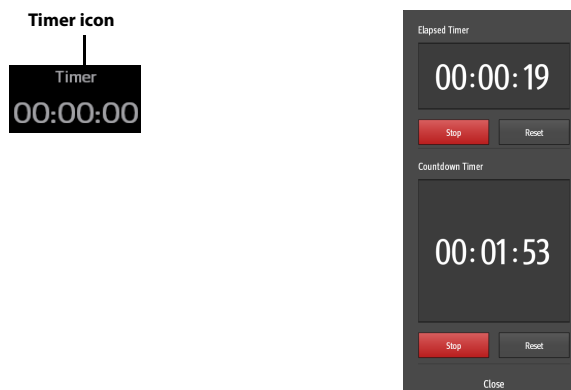



Figure 4-4 Timer

Elapsed timer

Select the **[Start]** soft key to start the elapsed timer. Select the **[Stop]** soft key to stop the elapsed timer. Select the **[Reset]** soft key to reset the timer.

Countdown timer

Set the remaining time for countdown and select the **[Start]** soft key to start the countdown. Select the **[Stop]** soft key to stop the countdown timer. Select the **[Reset]** soft key to reset the timer. The system will pop up a dialog box and beep when the countdown is over. In the dialog box, select  to turn off the system beep.

4.2.3 Alarm and Prompt Message

Displays physiological alarms, technical alarms and prompt messages. The most recent and top-priority alarm is displayed in the topmost section. Other alarms are displayed in the lower section, grouped by priority. In each group, the most recent alarm is displayed on the top of the list. Select the zone to display a list of all active alarms. See the table in Section "Alarms and Prompt Messages" on Pages 8-12 for a list of prompt messages and related priorities. Alarms with a high priority are displayed in red. Alarms with a medium priority are displayed in yellow. Alarms with a low priority are displayed in cyan. Prompt messages are displayed in white (Figure 4-5).



Figure 4-5 Alarms and Prompt Messages

4.2.4 Audio Pause/Alarm Reset icon

Select the **[Audio Pause]** soft key to display the Audio Pause icon and a 120-second countdown timer, indicating that all the audio alarms will be paused for 120 seconds.

When there is a medium priority or high priority alarm in the active alarms, select the **[Alarm Reset]** soft key to display the Alarm Reset icon and a 120-second countdown timer, indicating that all the current audio alarms will be paused for 120 seconds.



Figure 4-6 Audio Pause icon



Figure 4-7 Alarm Reset icon

4.2.5 Screen Brightness

Select the screen brightness adjustment icon to adjust the brightness of the Main Screen or Status Screen on the pop-up screen.

 indicates the lowest brightness and  indicates the highest brightness.

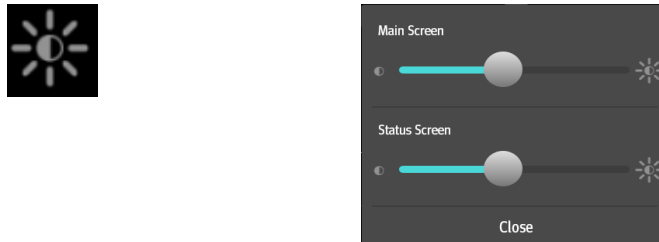

Figure 4-8 Screen brightness adjustment icon

4.2.6 Volume

Select the volume adjustment icon to adjust the alarm volume, the system alert volume, the key click volume on the pop-up screen.

 indicates the lowest volume.  indicates the highest volume.  indicates that the volume is turned off.

- Alarm Volume: it controls the volume of the physiological alarms and technical alarms.
- System Alert Volume: it controls the alert volume of the ventilation mode not selected and countdown timer expired. It also controls the volume of Capture Event/Screen and power off.
- Key Click Volume: it controls the volume of key clicking.

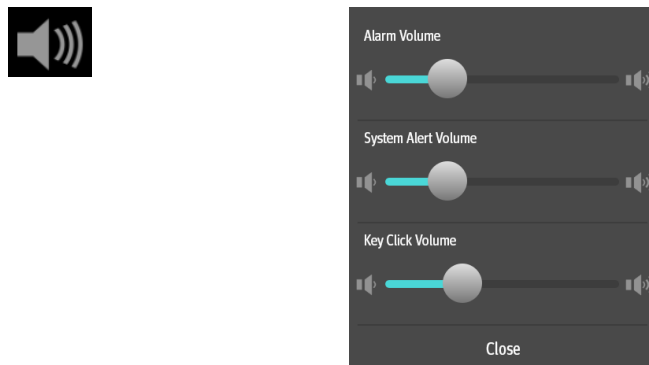

Figure 4-9 Volume adjustment icon

4.2.7 Date and Time

Displays the current system date and time (Figure 4-10).

2021-04-01
05:00:00 PM

Figure 4-10 Date and time icon

To adjust the date and time:

1. Enter Standby mode.
2. Select the  icon to open the [Setup] menu.
3. Select the [System] soft key, enter the system password and confirm the password.
4. Select the [Setup] tab in the system menu.
5. Select the [Time/Date] tab.
6. Adjust [24 Hour Time], [Time Zone], [Date], [Time], [Date Format] and [Daylight Savings Time] in the pop-up menu. See (Pages 4-37) 4.7.8.2 "Setup".

NOTE: Select [Daylight Savings Time], if applicable, before performing other settings.

7. Select  to confirm the changes.

4.2.8 Battery Status

Displays the main power supply and battery status(Figure 4-11).



Figure 4-11 Battery status icon

The power management system of the equipment supplies AC power to primary system features and charges the internal battery of the system. When the AC power supply suffers a fault, the equipment will be powered by the battery. See "Electrical Specifications" on Pages 10-6.

The equipment provides four (4) auxiliary AC power outlets. When the equipment is powered by its internal battery, the auxiliary AC power outlet is not live.

NOTE: To extend the service life of the battery, please use the battery at least once every three months. Charge the battery before the battery runs out.

NOTE: Check and replace the battery regularly. The service life of the battery depends on the frequency and duration of use. Improper use of the battery may shorten its service life. It is recommended that the lead acid battery be replaced once every three (3) years.

NOTE: The battery's power supply time depends on the equipment configuration and operation.

NOTE: In the event of a fault with the battery, contact our company's maintenance personnel for replacement.

The anesthesia system is equipped with an internal chargeable battery to ensure normal operation of the system in a power failure. When the equipment is connected to an AC power supply, the battery is charged regardless of whether the equipment is on or off. In the event of a sudden power failure, the system will automatically switch to the battery power supply mode without interrupting the operation of the system. When the AC power supply resumes within a specified period of time, the battery will start to be charged and the system will automatically switch from the battery to the AC power supply to ensure continuous operation.

When the power failure lasts shorter than 60 seconds (inclusive), the alarming settings before the power failure will be automatically restored.

The battery icon on the screen indicates the status of the battery.





PARTS	DESCRIPTION
	Battery is fully charged. AC power supply is connected. Equipment is powered by the AC power supply. The solid part of the battery icon represents the remaining battery level.
	Battery is partially charged. AC power supply is connected and charging the battery. Equipment is powered by the AC power supply.
	Battery is fully charged. AC power is not connected. Equipment is powered by the internal battery.
	Battery is partially charged. AC power is not connected. Equipment is powered by the internal battery.
	Battery is low. The battery should be charged immediately to work as a safe backup power supply. AC power is not connected. Equipment is powered by the internal battery.
	Battery is not installed.

Table 4-3 Battery status

Low battery may cause power supply faults. The equipment will trigger a high priority alarm and display [**Low Battery Voltage!**] in the Technical Alarm area. In this case, use the AC power supply to power the anesthesia system to resume its normal operation and charge the battery.

4.3 Fresh Gas Flow Display

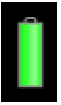
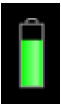
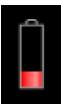
4.3.1 Electronic Flow Control System

Displays the real-time flow of O₂ or balance gas. The balance gas can be set to air or N₂O.

The flow meter numerics display a precision to two decimal digits for flows < 1 L/min and one decimal digit for flows ≥ 1 L/min.

In this equipment, the electronically-controlled flow meter is called the Electronic Flow Control System (hereinafter referred to as the EFCS). EFCS has two control modes available: Total Flow and Direct Flow.

4.3.1.1 Total Flow Control Mode

The total flow control mode of the EFCS is shown in the figure below:

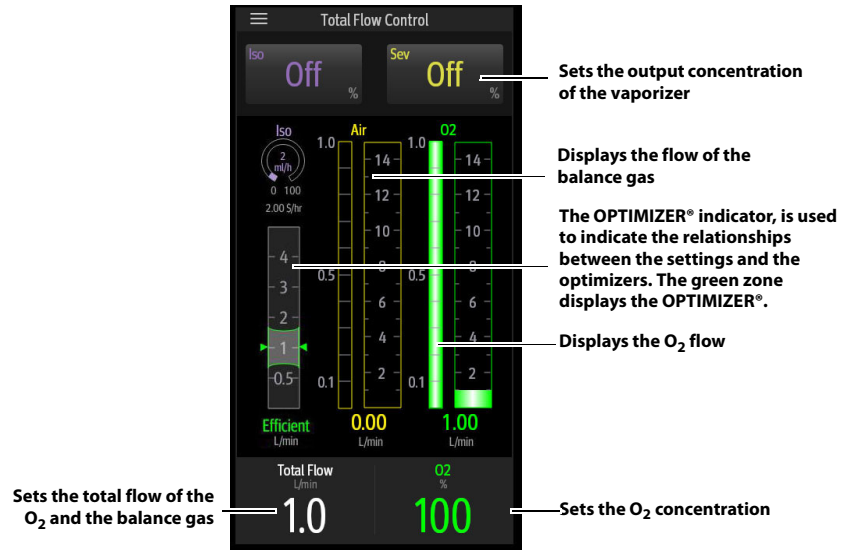

Figure 4-12 Total Flow Control mode

Select the soft key in fresh gas flow display zone and open the following total flow control menu.



Figure 4-13 Total Flow Control menu

You can perform the following settings in the Total Flow Control menu:

- Set 100% O₂ flow rate using quick keys.
- Set the [Control Mode] to [Total Flow] or [Direct Flow].

- Set the [Balance Gas] to [Air], [N₂O] or [None].
- Set the total flow.
- Set the O₂ concentration value.
- Set the anesthetic agent concentration of the vaporizer.

4.3.1.2 Direct Flow Control mode

The direct flow control mode of the EFCS is shown in the figure below:

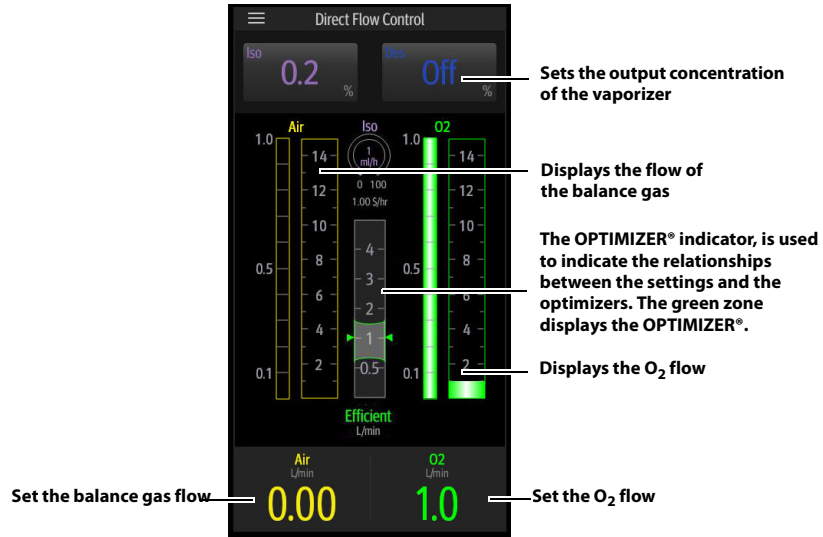

Figure 4-14 Direct Flow Control mode

Select the soft key in fresh gas flow display zone and open the following direct flow control menu.



Figure 4-15 Direct Flow Control menu

You can perform the following settings in the Direct Flow Control menu:

- Set 100% O₂ flow rate using quick keys.
- Set the [Control Mode] to [Total Flow] or [Direct Flow].
- Set the [Balance Gas] to [Air], [N₂O] or [None].
- Set the balance gas flow.
- Set the O₂ flow.
- Set the anesthetic agent concentration of the vaporizer.

4.3.1.3 OPTIMIZER®

WARNING: The fresh gas OPTIMIZER® indicator must not be used when high-flow fresh gas is needed.

NOTE: The OPTIMIZER® is effective only when the anesthesia system is configured with the AG or the anesthesia system has access to the AG or CO₂ data from the monitor (Passport 12M / 17M), and the anesthesia system is in the automatic ventilation mode.

NOTE: The OPTIMIZER® feature will become ineffective and unavailable when the data for OPTIMIZER® calculation is not valid.

The OPTIMIZER® indicator is used to indicate the relationships between the settings and the optimizers.

The green zone displays the OPTIMIZER® in a 1L/min range. The triangle pointers indicate the measured value of the total flow. If the triangle pointers are higher than the green zone, the triangle pointers and the indication text of [High] are in yellow. If the triangle pointers are in the green zone, the triangle pointers and the indication text of [Efficient] are in green. If the triangle pointers are lower than the green zone, the triangle pointers and the indication text of [Low] are in red (Figure 4-16).

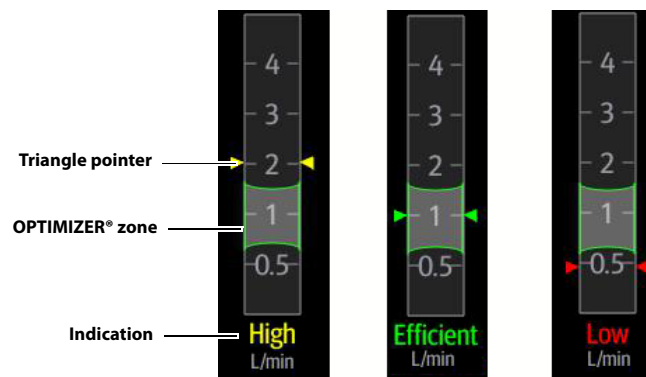



Figure 4-16 OPTIMIZER®

To enable or disable the OPTIMIZER® indicator, do the following:

1. Enter Standby mode.
2. Select the  icon to open the [Setup] menu.
3. Select the [System] soft key, enter the system password and confirm the password.
4. Select the [Setup] tab in the system menu.
5. Select the [Optimizer] tab.

6. Set **[Optimizer]** to  (off) or  (on).

If the anesthesia system is connected with the monitor, the anesthesia system can have access to the AG or CO₂ data from the monitor (Passport 12M / 17M). Perform the following operations:

1. The network cable is connected to the ethernet interface of the anesthesia system on one end and connected to the ethernet interface of the monitor on the other end.
2. Enter Standby mode.
3. Select the  icon to open the **[Setup]** menu.
4. Select the **[System]** soft key, enter the system password and confirm the password.
5. Select the **[Network]** tab in the system menu.
6. Select the **[Optimizer Source]** tab.
7. Set the **[IP Address]** and **[Multicast Address]**.

NOTE: The IP addresses of the anesthesia system and the monitor must be in the same segment.

8. Select the **[Test]** soft key. Make sure that the test result is **[Pass]**.

The OPTIMIZER® indicator is invalid in the following circumstances:

- The automatic circuit leak test is not executed or fails.
- The Vt, MV, EtCO₂ or FICO₂ parameter values are invalid.
- The alarms listed in the following table are triggered.

ALARM MESSAGES	THE OPTIMIZER® INDICATOR BECOMES INVALID WHEN AN ALARM IS TRIGGERED
Apnea	Yes
Apnea>2 min	Yes
Apnea CO ₂	Yes
Flow Sensor Failure	Yes
Check Flow Sensors	Yes
Pinsp Not Achieved	Yes
Vt Not Achieved	Yes
Patient Circuit Leak	Yes
CO ₂ Absorber Canister Not Locked	Yes
Ventilator Control Board Communication Stopped	Yes
Drive Gas Pressure Low	Yes
AG Module Error	Yes
AG Self Test Error	Yes
AG No Watertrap	Yes
AG Change Watertrap	Yes
AG Airway Occluded	Yes
AG Zero Failed	Yes
EtCO ₂ Over Range	Yes
FICO ₂ Over Range	Yes

4.3.2 Backup Flow Control System

If the EFCS fails, the system automatically opens the Backup Flow Control System (hereinafter referred to as the BFCS) cover, and adjusts the gas flow with the needle valve of flowmeter. Before the EFCS is restored, you cannot disable the BFCS.

The BFCS screen is shown in the figure below:



Figure 4-17 Backup Flow Control System

After the BFCS is enabled, the system will automatically provide O₂ flow at 1L/min. Rotate the needle valve to adjust the flow, and the flow will increase the flow from 1L/min. The total flowmeter is used to display the total flow. With the O₂ concentration displayed on the screen, you can manually calculate the O₂ flow and balance gas flow. By pressing the **[Audio Pause]** or **[Alarm Reset]** button, you can disable the audio alarm of **[Backup Flow Control is enabled]**.

When the EFCS is still on, you can pull the BFCS cover outward to start the BFCS. To disable the BFCS, close all the needle valves and press the **[Disable Backup Flow Control]** button on the screen. Then select **[Yes]** in the pop-up dialog box and close the BFCS cover to disable the BFCS.

When the **[Low Battery Voltage!]** alarm shows, the system will prompt to use the BFCS to control the flow. Please connect the system to an AC power supply as soon as possible.

4.4 Waveform/Parameter/Spirometry/Trend Display Zone

Displays the pressure, flow rate, volume, CO₂, O₂, N₂O, and AA waveforms; displays the monitoring parameters; displays spirometry; displays the mini trends and compl/PEEP trends.

Select this control to set the desired waveforms, parameters, spirometry and trends to display.

Select this control to set the desired spirometry screen to display.

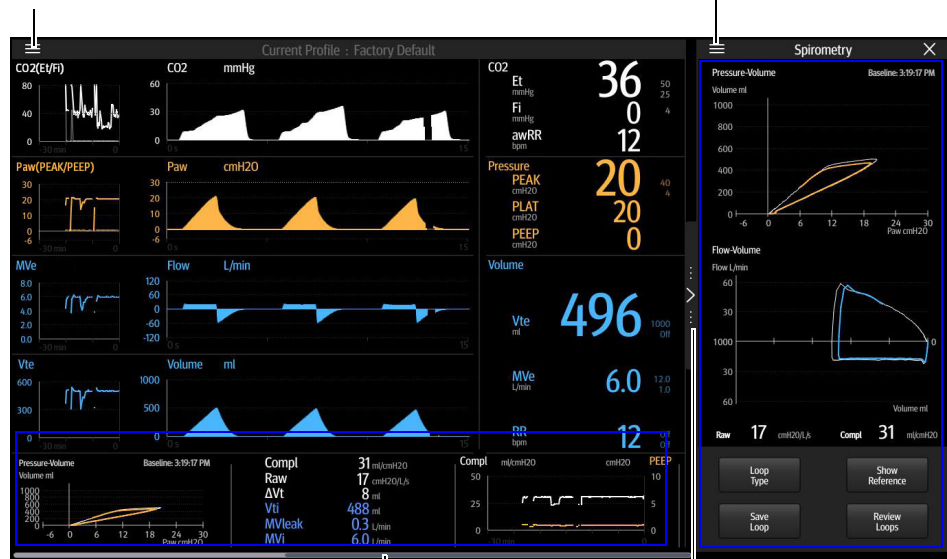

Scroll bar. Generally, scrolling the bar will show more data.

Select the control to expand or collapse the zone on the right.

Figure 4-18 Waveform/parameter/spirometry/trend display zone

4.4.1 Waveform/Parameter Screen

Displays the pressure, flow rate, volume, CO₂, O₂, N₂O, and AA waveforms and monitoring parameters.

Select this control to select the desired waveforms and monitoring parameters to display on the pop-up screen.

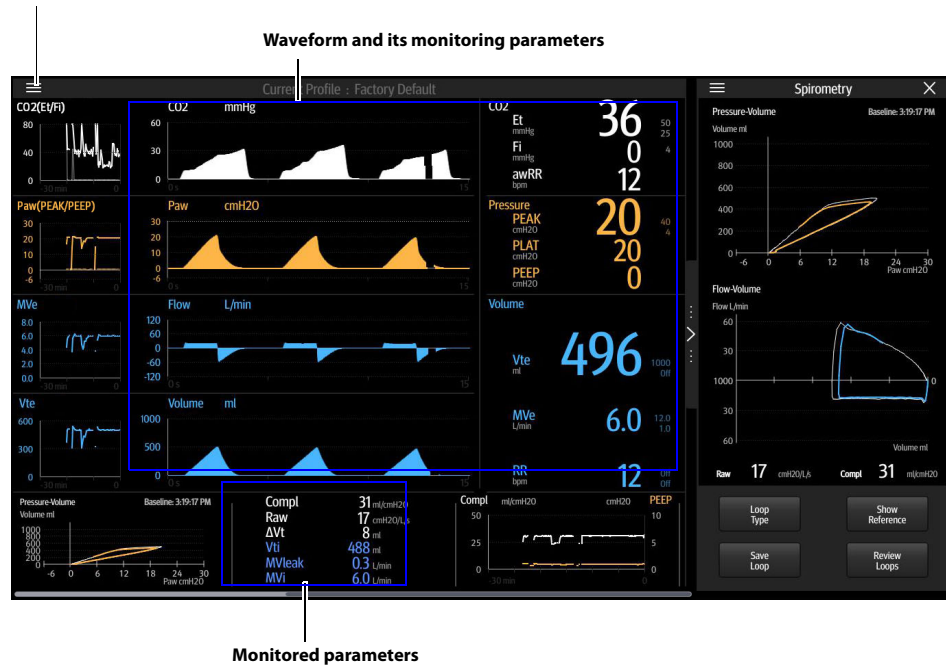

Figure 4-19 Waveform/parameter screen

4.4.2 Spirometry Screen

Spirometry loops reflect patient lung function and ventilation. They also indicate other related parameters such as compliance, over-inflation, breathing system leak, and airway blockage.

The system provides three types of spirometry loops: pressure - volume loop, flow - volume loop and pressure - flow loop. Loops data comes from pressure and flow data. A maximum of two loops are displayed at a time.

Four soft keys are displayed on the Spirometry screen: Loop Type, Show Reference, Save Loop and Review Loops.

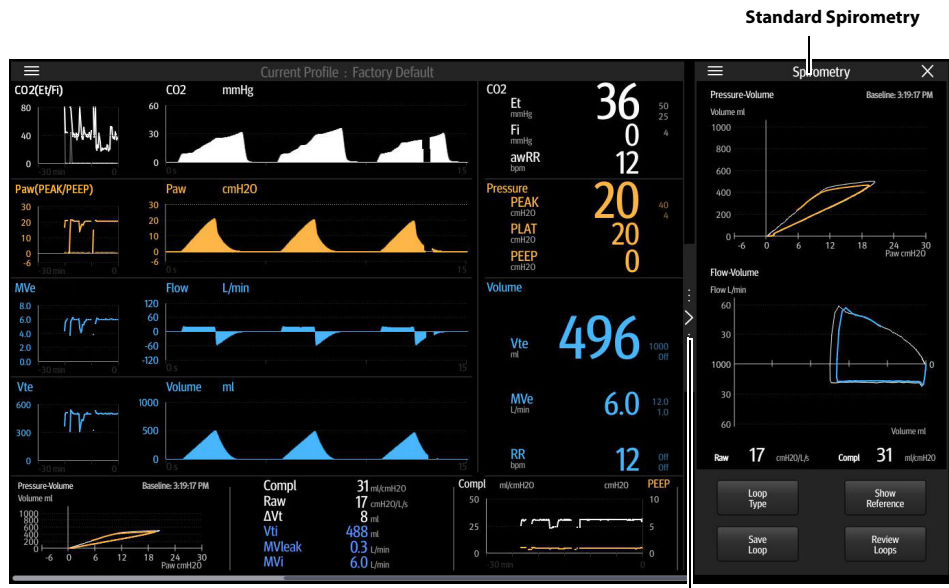

Select this control to expand the large loop screen. (The large loop screen displays one loop.)

Figure 4-20 Spirometry (standard loop screen, two loops are displayed)

4.4.2.1 Loop Type

The [Loop Type] option is used to display the P-V, the F-V, or the P-F loop on the spirometry screen.

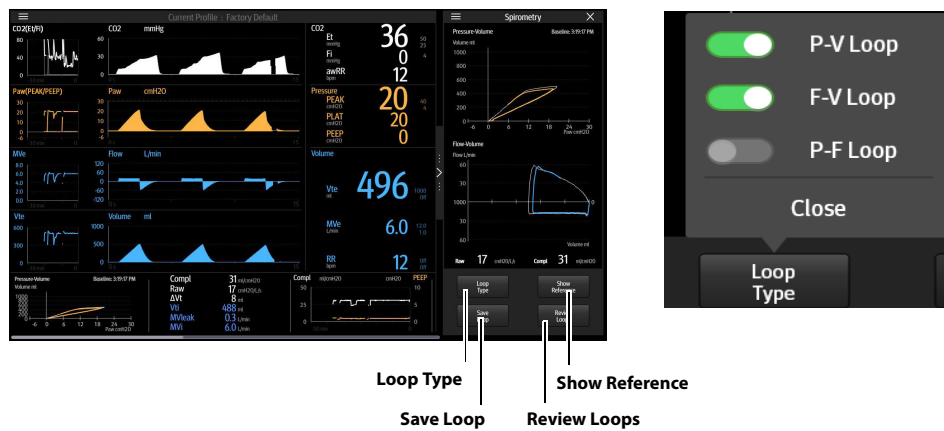

Figure 4-21 Soft keys of loops: Loop Type, Show Reference, Save Loop and Review Loops

4.4.2.2 Show Reference

Select [Show Reference] softkey only after saving a baseline via the [Save Loop] softkey.

[**Show Reference**] soft key is used to select and display the saved baseline loop and reference loop, or hide the loops (disable) in the loop window. The selected baseline loop or reference loop will be shown overlapped with the current loop. Only the most recent five reference loops saved will be displayed in the chronological order.

After the reference loop or baseline loop to display in the loop window are selected, the timestamp will also be displayed.

4.4.2.3 Save Loop

Select the [**Save Loop**] soft key to save the current loop (including its monitoring parameter data) as a baseline loop or reference loop. You can save a maximum of one baseline loop and five reference loops. Other loops can be saved to replace the baseline loop or reference loops. Only the most recent five reference loops are saved.

Review the saved baseline or reference loop with its numeric data (via [**Review Loops**] softkey) or displayed with the currently plotting loop on the same graph for comparison (via [**Show Reference**] softkey).

NOTE: **A reference loop cannot be saved without first saving a baseline loop. The System always makes the first saved loop as the baseline loop if no previous loops have been saved. Afterward, additional loops can be saved either as a baseline replacement or as a new reference loop.**

To save a baseline loop:

1. On the Spirometry Screen, select the [**Save Loop**] soft key. If no baseline loop has been saved, the current loop will be automatically saved as a baseline loop.
2. If a baseline loop has been saved, a dialog box will pop up, offering the [**baseline loop**] and [**reference loop**] options. After saving a loop as a [**baseline loop**], a confirmation box will pop up with a prompt message saying [**Selecting 'Yes' will overwrite the current baseline loop saved. Confirm to continue?**]. If [**Yes**] is selected, the currently saved baseline loop will be replaced. If [**No**] is selected, the save will be canceled.

To save a reference loop:

1. On the Spirometry Screen, select the [**Save Loop**] soft key. If a baseline loop has been saved, a dialog box will pop up, offering the [**baseline loop**] and [**reference loop**] options. Select [**reference loop**].

You can save a maximum of five (5) reference loops and one (1) baseline loop along with their monitoring parameter data.

When the maximum of five (5) loops is reached, and the user attempts another save, a confirmation dialog will be displayed with the following text, [**Selecting 'Yes' will overwrite the earliest saved reference loop. Confirm to continue?**]. If [**Yes**] is selected, the oldest data will be removed as the new data is added. If [**No**] is selected, the save will be canceled.

4.4.2.4 Review Loops

Select the [**Review Loops**] soft key to display the [**Review Loops**] screen, with the following zones and options available:

Small Loop Window: These small loop windows display the baseline loop and the reference loops. The baseline loop (only one) is always displayed on the top. The reference loops (five at most) are displayed under the baseline loop. The reference loops are sorted in the chronological order from the earliest (up) to the latest (bottom).

The baseline loop information is displayed on the right side of the small baseline loop window.

Large Loop Window: The loop window displays the enlarged view of the selected reference loop and is shown overlapped with the baseline loop.

Loops Type: Used to select the type of the loop to be reviewed. P-V loop, F-V loop and P-F loop options are available. P-V loop is the default option.

Delete Loops: The [Delete] option is used to delete a selected reference loop. After a reference loop is deleted, the new reference loop will move to the top. If no reference loops have been saved, the [Delete] key will be disabled (turning gray). The baseline loop cannot be deleted. It can only be replaced by a new baseline loop.

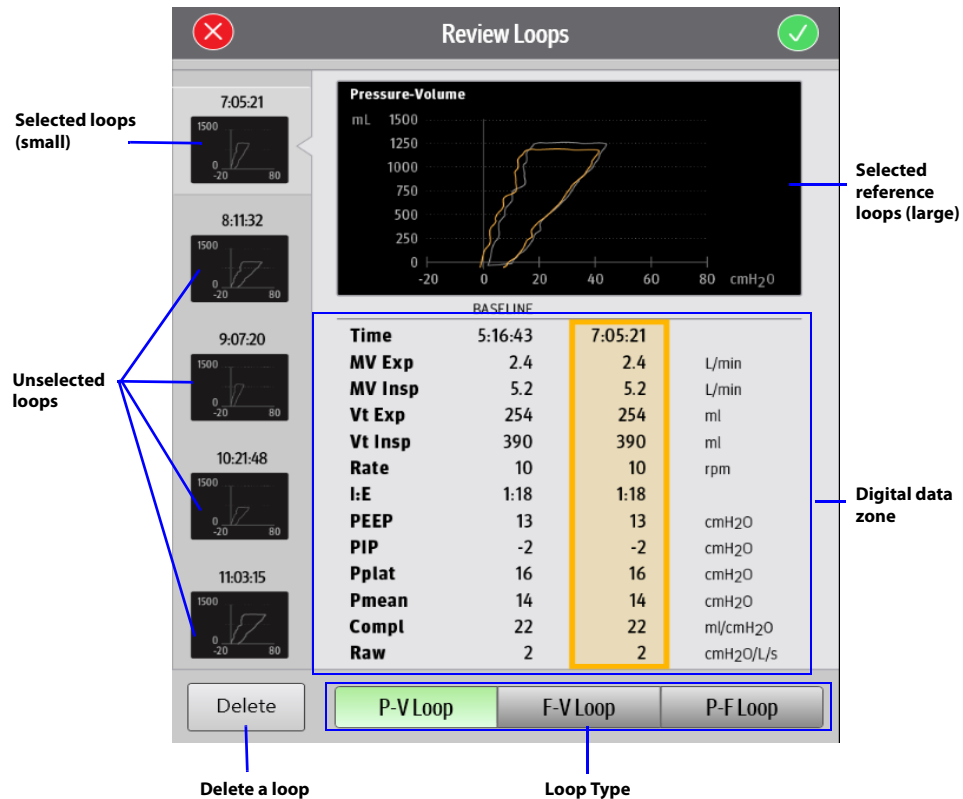

Figure 4-22 Review Loops window

Parameter data zone: Displays the monitoring parameter data related to the saved baseline loop and reference loops. Listed parameters include: **time**, **minute expiratory volume (MV Exp)**, **minute inspiratory volume (MV Insp)**, **expired tidal volume (Vt Exp)**, **inspiratory tidal volume (Vt Insp)**, **inspiration/expiration ratio (I:E)**, **positive end-expiratory pressure (PEEP)**, **respiratory rate (RR)**, **peak inspiratory pressure (PEAK)**, **inspiratory plateau pressure (Pplat)**, **mean pressure (Pmean)**, **dynamic airway compliance (Compl)** and **airway resistance (Raw)**.

4.4.2.5 Freeze loop

Select the key  to expand the large Spirometry loop screen, which contains the Freeze softkey.

When the Freeze softkey is selected, the system enters the Freeze status. The system pauses real-time refreshes of Spirometry on the screen to facilitate a brief review of the patient's data for more in-detail examination of the patient's conditions within the period of time. Tap the screen or rotate the main control knob to move the cursor to view the value at any point on the spirometry loop. Select the Freeze softkey again to exit the Freeze status. In Freeze status, if no operation is performed on the system for more than three minutes, the system exits Freeze status automatically.

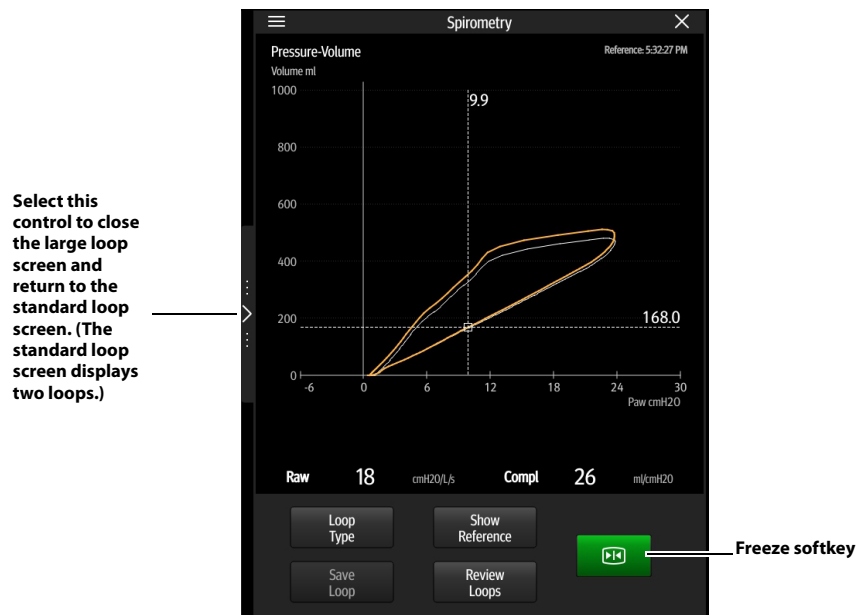



Figure 4-23 Freeze loop (large loop screen, only one loop is displayed)

4.4.3 Mini Trends Screen

Mini trends screen displays trend waveforms that correspond to the waveforms. The Mini Trends duration can be set as follows:

1. Select the  icon > **[Screen]** tab.
2. Set **[Mini Trends Duration]** to [5 Min], [15 Min], [30 Min], [1 Hour] or [2 Hour].

Select this control to enable or disable the mini trends waveform on the pop-up screen.

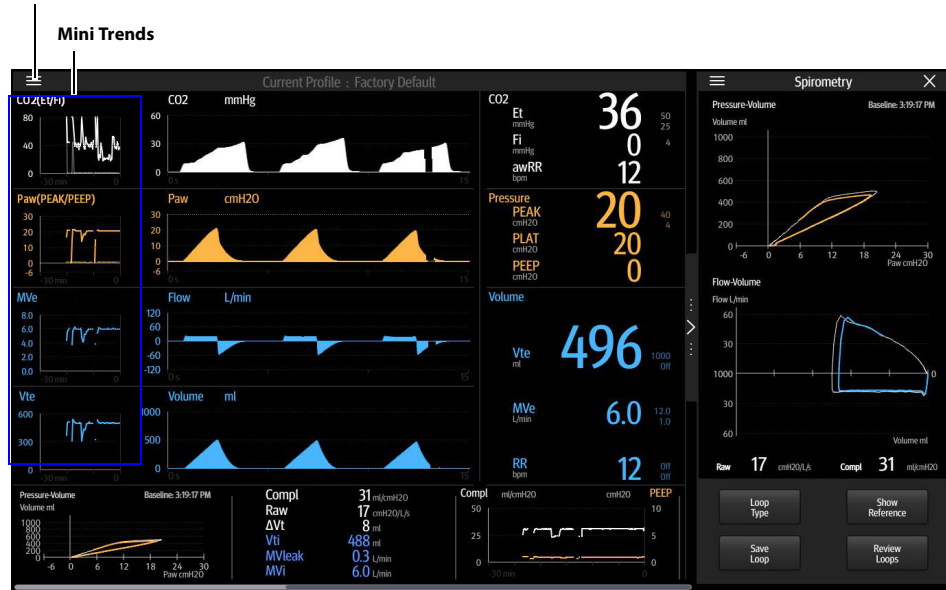



Figure 4-24 Mini Trends

4.4.4 Compl/PEEP Trend Screen

Compl and PEEP trend waveforms are displayed at the same time on the pop-up screen. The Compl/PEEP Trend duration can be set as follows:

1. Select the  icon > [Screen] tab.
2. Set [Mini Trends Duration] to [5 Min], [15 Min], [30 Min], [1 Hour] or [2 Hour].

Select this control to enable or disable the Compl/PEEP trend on the pop-up screen.

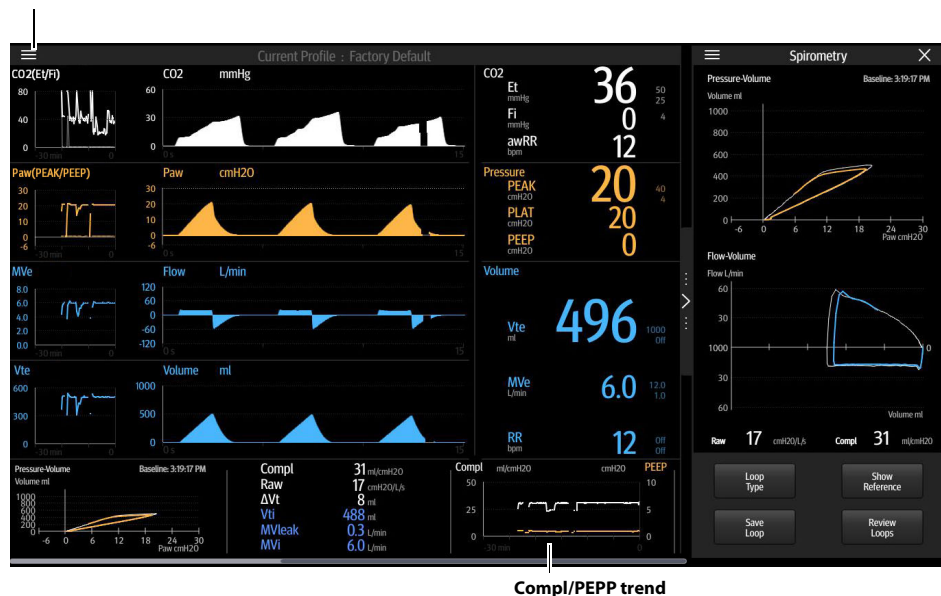

Figure 4-25 Compl/PEEP Trend

4.5 Ventilation Mode Tabs

Displays tabs for ventilation modes. Each tab displays the ventilation mode and its parameters.

The ventilation modes on the screen can be customized. Select ventilation mode custom soft key to open **[Vent Mode Setup]** menu. In the opened menu, set the ventilation modes to be displayed in ventilation mode zone. The system will add one ventilation mode at a time according to the order of selection.

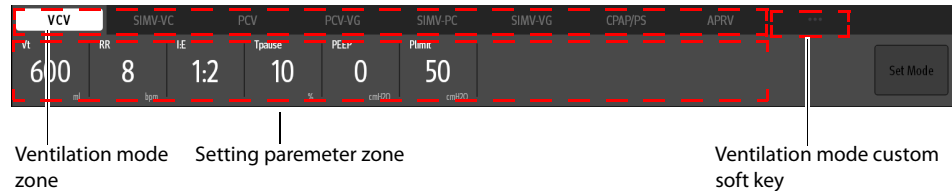

Figure 4-26 Ventilation Mode Tabs

To change the ventilation mode:

1. Select the desired ventilation mode tab, the **[Set Mode]** soft key will turn green and start to flash.
2. Optionally, select one or more parameter buttons to change the parameter settings of the desired ventilation mode. Select "✓" in the pop-up dialog box of parameter settings to confirm the changes to the parameter.
3. Select the **[Set Mode]** soft key to finalize the ventilation mode.

NOTE: If the **[Set Mode]** soft key is not selected after several seconds, the system will give audio alerts and then the desired ventilation mode will be canceled.

4.6 System Soft Key

System soft keys are provided on the right side of the Main Screen.

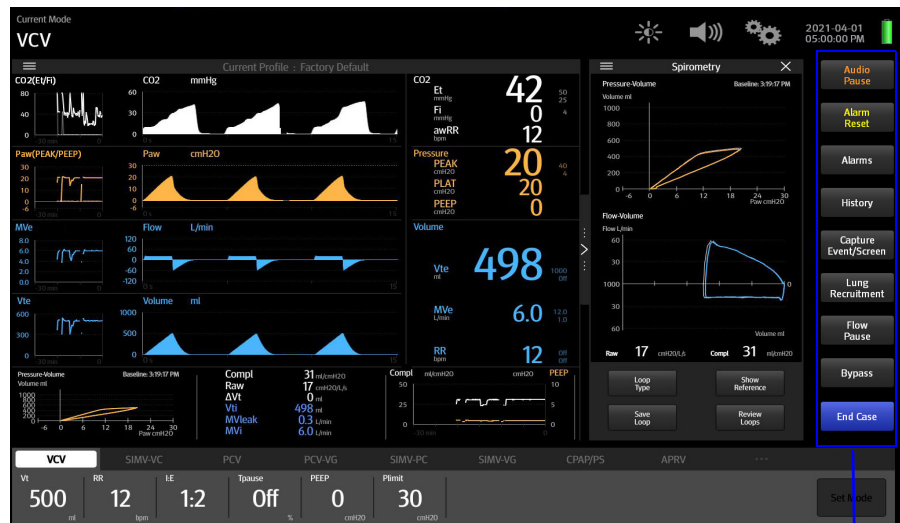

System soft keys

Figure 4-27 System soft keys

4.6.1 History

Select the **[History]** soft key on the Main Screen to open the **[History]** menu. The menu contains the List Trends, the Graphic Trends, the Event Log, Screen and Export tabs. The List Trends, Graphic Trends and Event Log tabs on the History screen are associated. When you switch among the tabs, the cursor is automatically positioned to the record that is related to the previous page.

4.6.1.1 List Trends

On the **[List Trends]** screen, you can view the parameter data and events of a patient. If no display interval is set, the trends will be displayed based on the data with an interval of one minute by default.

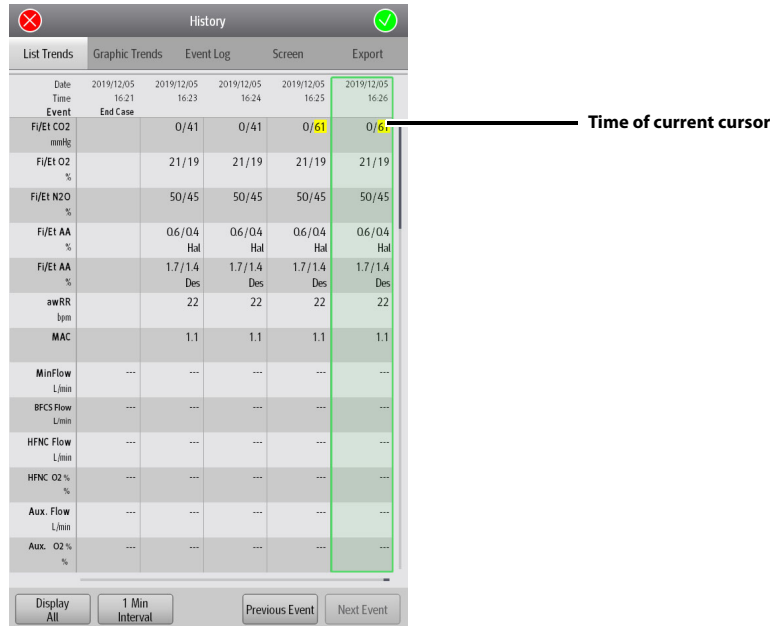

Figure 4-28 List Trends

4.6.1.1.1 About List Trends

- The horizontal coordinates of a list trend show the time and date.
- List Trends displays the parameter name on the vertical axis and it is always visible.
- List Trends displays the trend records in descending order beginning with the most recent on the right side of the grid.
- Graphic Trends are not stored when the system is in standby.
- List Trends can display the trend data of 48 consecutive hours.
- List Trends highlights the parameter data in the corresponding alarm color if an alarm condition existed for the parameter at the time of trend record storage.

4.6.1.1.2 List Trend Events Buttons

Drag the horizontal or vertical progress bar to view the updated trend data.

BUTTON

Previous Event

FUNCTION

The cursor moves from the current event to the previous event.

BUTTON	FUNCTION
Next Event	The cursor moves from the current event to the next event.

Table 4-4 List Trend Events Buttons

4.6.1.1.3 Display Interval

In the List Trends menu, you can set the display interval to [1 Min], [5 Min], [10 Min], [15 Min], [30 Min], [1 Hour] and [2 Hour].

4.6.1.1.4 Display Group

In the List Trends menu, you can set the display group to [Gas], [Gas Flow], [Ventilator] and [All].

4.6.1.2 Graphic Trends

Graphic trends display allows the user to observe the trend of the physiological parameters. The trend is reflected through a curve. Every point on the curve corresponds to the parameter value at a specific time point. Graphic trends can also record standby and parameter alarm events. Graphic trend data automatically displays in one minute intervals unless the zoom is selected.

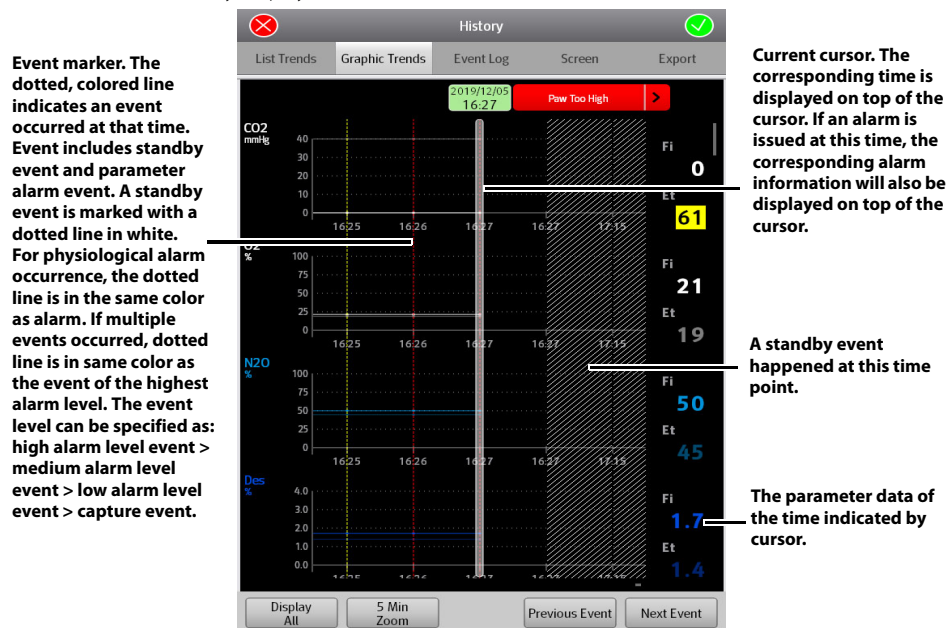

Figure 4-29 Graphic Trends

4.6.1.2.1 About Graphic Trends

- Graphic Trends store the data with the interval in 1 minute.
- Graphic Trends displays the trend records in descending order beginning with the most recent.
- Graphic Trends are not stored when the system is in standby.
- The display period of data is a rolling 48 hours of continuous data.
- Graphic Trends highlights the parameter data in the corresponding alarm color if an alarm condition existed for the parameter at the time of trend record storage.

4.6.1.2.2 Graphic Trend Events Buttons

Drag the horizontal or vertical progress bar to view the updated trend data.

BUTTON	FUNCTION
Previous Event	The cursor moves from the current event to the previous event.
Next Event	The cursor moves from the current event to the next event.

Table 4-5 Graphic Trend Events Buttons

4.6.1.2.3 Zooming

In the Graphic Trends menu, you can set the zooming to [1 Min], [5 Min], [10 Min], [15 Min], [30 Min], [1 Hour] and [2 Hour].

4.6.1.2.4 Display Group

In the Graphic Trends menu, you can set the display group to [Gas], [Gas Flow], [Ventilator] and [All].

4.6.1.3 Event Log

The [Event Log] tab can record the technical alarms, physiological alarms, capture events, power-off delays, standbys, canceled power-off delays, system time changes, lung recruitments, system self-tests, vaporizer checks and leak tests.

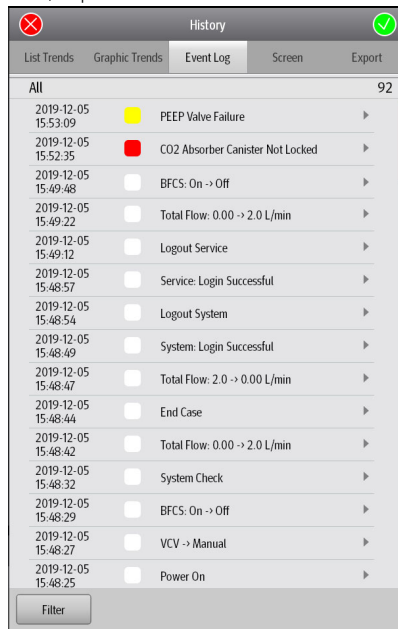

Figure 4-30 Event Log

NOTE: Event logs will not be cleared after the anesthesia system powers off.

NOTE: The system can store up to 10,000 events. After the number of events exceeds 10,000, the earliest event will be overwritten by the latest event.

4.6.1.3.1 Filter

In the Event Log menu, you can set [Filter] to [High], [Medium], [Low], [Informational], [Activity] and [All On].

4.6.1.4 Screen

You can select and delete captured screens. Select the [Capture Event/Screen] soft key on the Main Screen to capture the current screen and save it as an image. You can save up to 50 captured screens.

4.6.1.5 Export

Insert a U disk to the USB interface of the equipment as per the prompts on the screen. Select the **[Export]** soft key to export list trends, graphic trends, event logs and captured screens to the U disk. The exported data is in the format of .html. Files in the format can be opened in Internet Explorer 8.0, 9.0, 10.0 and 11.0.

4.6.2 Lung Recruitment (Optional)

See (Pages 6-14) 6.6.10 "Lung Recruitment Ventilation (Optional)".

4.6.3 Flow Pause

Use **[Flow Pause]** to temporarily suspend fresh gas flow during the ventilation. Using **[Flow Pause]** while the breathing system is disconnected from patient prevents the flow of gas into the room. **[Flow Pause]** is available during both mechanical ventilation and manual ventilation.

To enter the **[Flow Pause]** state:

1. On the Main Screen, select the **[Flow Pause]** soft key.
2. Select **[Yes]** on the pop-up screen to confirm the change. The system will enter the **[Flow Pause]** state.

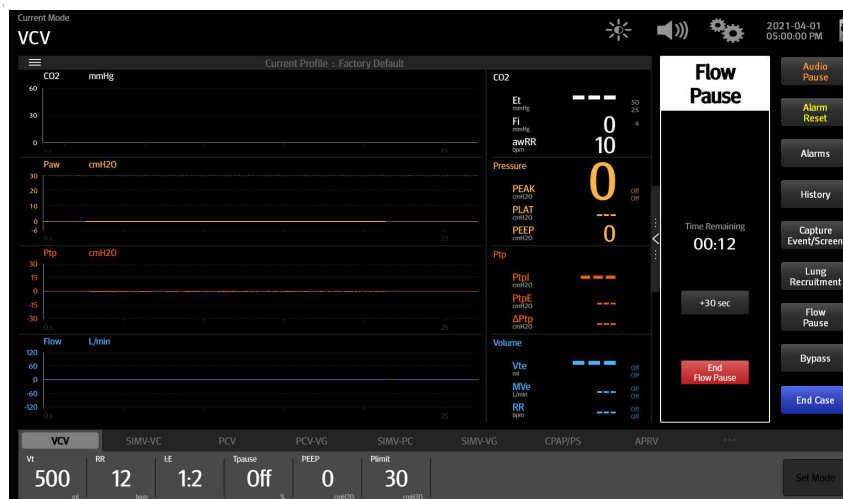

Figure 4-31 Flow pause

When the system is in the **[Flow Pause]** state:

- The fresh gas flow is turned off.
- The mechanical ventilation is suspended.
- Physiological alarms related to ventilation and gas are disabled.
- The countdown timer is enabled. The default countdown time is 60 seconds. You can select **[+30 sec]** button to add 30 seconds to the current countdown time. The maximum countdown time is 2 minutes.

To exit the **[Flow Pause]** state:

- The system exits the **[Flow Pause]** state automatically when the countdown time is 00:00.
- Select **[End Flow Pause]** button to exit the **[Flow Pause]** state.
- The system exits the **[Flow Pause]** state automatically when the system enters Standby mode or the BFCS is enabled.

After the system exits from the **[Flow Pause]** state:

- The fresh gas flow resumes at the settings from before entering the **[Flow Pause]** state.
- Ventilation resumes in the same ventilation mode and with the same parameter settings as before entering the **[Flow Pause]** state.
- Physiological alarms related to ventilation and gas are enabled.

4.6.4 Cardiac Bypass Mode

See (Pages 6-19) 6.7.3 "Cardiac Bypass Mode".

4.6.5 Screens

Select the **[Capture Event/Screen]** soft key, and the system will save the current screen as an image in the **[png]** format and log the current monitoring and event to the Event Log (See Pages 4-26 "Event Log"). The anesthesia system can store up to 50 images.

4.6.6 Alarms

Select the **[Alarms]** soft key on the Main Screen to open the **[Alarms]** menu where you can set the alarm limits and view active alarms (See (Pages 8-1) 8.0 "Alarms and Messages").

4.6.7 Alarm Reset

See (Pages 8-8) 8.6 "Setting Alarm Limits".

4.6.8 Audio Pause

See (Pages 8-7) 8.4 "Pause Alarm Audio".

4.7 Setup Menu

Select the  icon to open the **[Setup]** menu (Figure 4-35).

NOTE: The **[System]** soft key is only available in the standby mode.

NOTE: The **[Service]** tab is for use only by Mindray Technical Service. Please contact Mindray Technical Support for details.

4.7.1 Ventilation

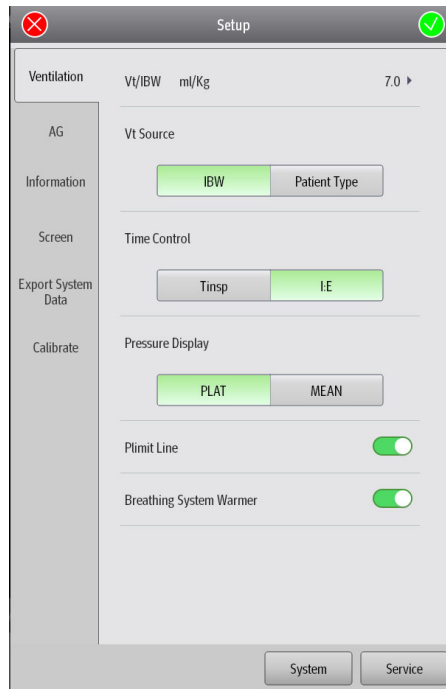

Figure 4-32 Ventilation (taking AG module configuration for example)

Vt/IBW

The system calculates the default tidal volume in the ventilation mode based on the [Vt/IBW] value. It is available for the VCV, SIMV-VC, PCV-VG, and SIMV-VG modes.

Vt Source

Set the [Vt Source] to [IBW] or [Patient Type]. When the [Vt Source] is set to [Patient Type], changes to [IBW] won't impact [Vt] setting. When the [Vt Source] is set to [IBW], changes to [IBW] will impact [Vt] and [RR] settings based on the aforementioned Vt/IBW result.

Time Control

When [Time Control] is set to [I:E], the time control parameter in the VCV, PCV and PCV-VG ventilation modes is [I:E], and that in the PS and CPAP/PS ventilation modes is [Apnea I:E]. When [Time Control] is set to [Tinsp], the time control parameter in the VCV, PCV and PCV-VG ventilation modes is [Tinsp], and that in the PS and CPAP/PS ventilation modes is [Apnea Ti].

Pressure Display

Set the pressure monitoring to display on the Main Screen to [Plat] or [Mean].

Plimit Line

Set the [Plimit Line] to (off) or (on). The Plimit line function displays a dashed line in the Pressure waveform area to indicate the Plimit position. The Plimit line can be displayed in VCV, SIMV-VC, SIMV-VG and PCV-VG modes.

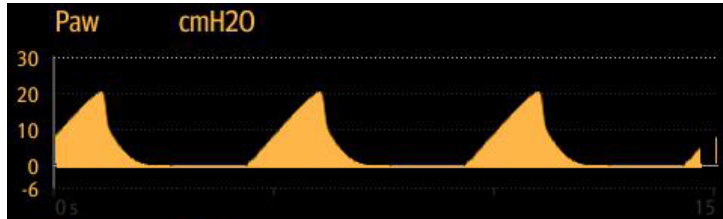

NOTE: The Plimit line does not affect the auto-scaling algorithm. If the Plimit line is turned on but not visible, it may be because the line is positioned off the waveform scale.

Breathing System Warmer

The [Breathing System Warmer] can be set to (off) or (on). If the [Breathing System Warmer] is (off), or if AC power is not connected, the system displays an icon to indicate that the warmer is not active.



After cycling power, the Breathing System Warmer will return to the default state.

NOTE: The Breathing System Warmer is inactive when the equipment is powered by battery.

4.7.2 Oxygen (O₂)

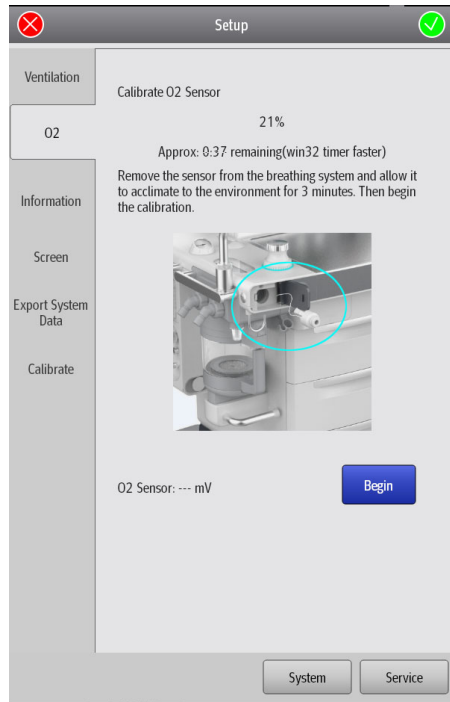

Figure 4-33 Oxygen (O₂)

Calibrate O₂ Sensor

You can select the **[Calibrate O₂ Sensor]** button to calibrate the O₂ sensor. Follow the prompts on the screen to perform the operation: See "21% Oxygen Calibration" on Pages 9-4 for more information.

4.7.3 AG Settings (AG module configured)

See (Pages 7-1) 7.0 "Anesthetic Gases and O₂ Concentration Monitoring" for more information.

4.7.4 Information

Displays the software version, network setup information and other related information of the equipment. The information is for view purpose only and does not support modifications.

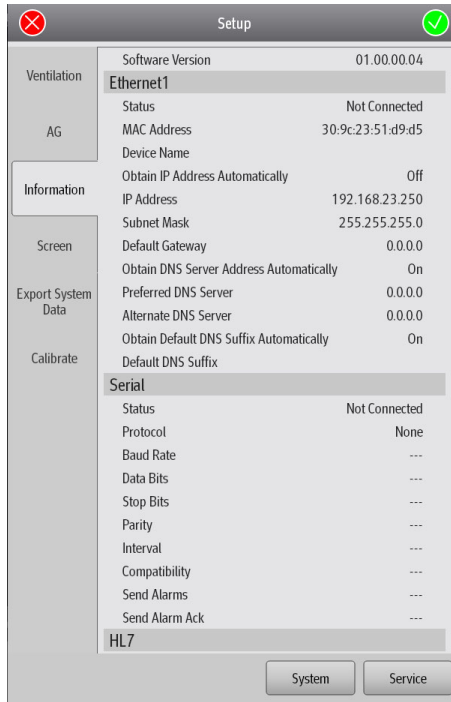

Figure 4-34 Information

4.7.5 Screen

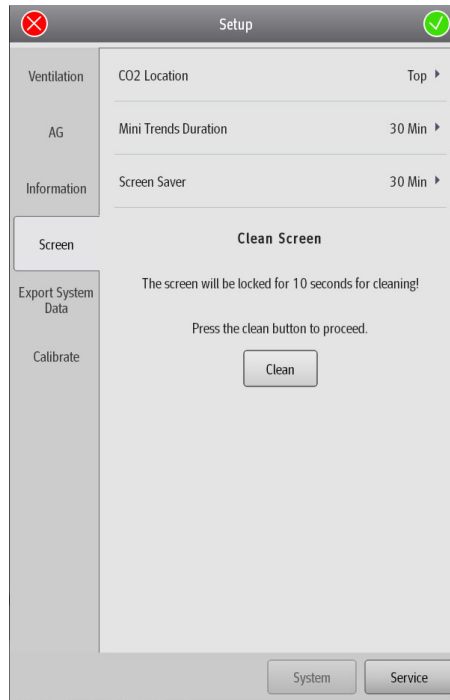

Figure 4-35 Screen

CO₂ Location

When the AG module is configured, the system will display the CO₂ waveform on the Main Screen. The [CO₂ Location] can be set to [Top] or [Bottom]. Based on the [CO₂ Location] setting, the system displays the CO₂ waveform at the corresponding location on the Main Screen.

Mini Trends Duration

See (Pages 4-21) 4.4.3 "Mini Trends Screen" and (Pages 4-22) 4.4.4 "Compl/PEEP Trend Screen".

Screen Saver

Set the delay time for entering the screen saver or disable the screen saver feature by setting it OFF. When the system enters the screen saver status, the status screen is displayed as blank, and the Main Screen displays Mindray at random locations as the screen saver. The system will exit from the screen saver when it detects the following operations:

- A touch on the Main Screen
- An operation on the main control knob
- An operation on either Flow Control Knob
- The BFCS cover is opened/closed
- The ACGO is enabled
- The HFNC is enabled
- The Auto/Manual switch is flipped
- A module is inserted/withdrawn (AG module)
- An vaporizer is installed/disassembled
- An alarm is issued

Clean Screen

When the **[Clean]** soft key is selected, the system will lock the screen for 10 seconds so that the display can be cleaned.

4.7.6 Export System Data

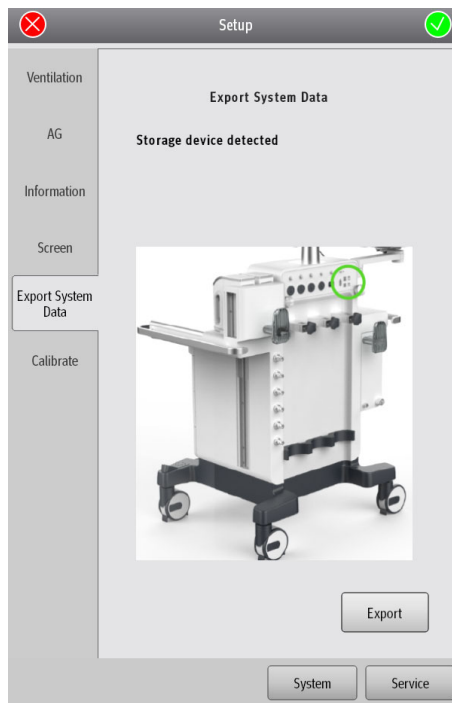



Figure 4-36 Export System Data

The anesthesia system can export system data. The system data includes the equipment information, logs, monitoring data, system information, historical data, captured screens and network information.

To export data from the system, follow the steps below:

1. As per the instructions on the screen, insert a U disk to the SB interface of the anesthesia system. The  icon is displayed on the Main Screen.
2. Select the **[Export]** soft key, and the system will check the remaining space of the U disk. If the remaining space is enough, the system will export the system data. Exported file is encrypted in the format of blg except the captured screens.
3. After the export is complete, select the  icon.
4. Select **[Yes]** in the pop-up dialog box, and remove the U disk.

4.7.7 Calibrate

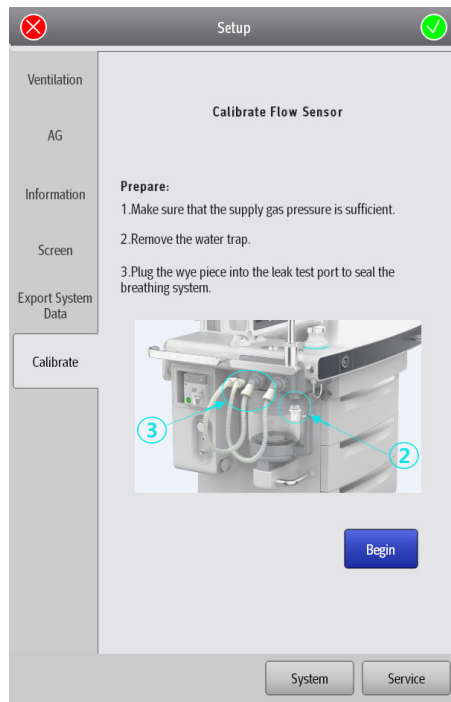

Figure 4-37 Calibrate

Follow the prompts on the screen to calibrate the flow sensor. See (Pages 9-4) 9.3 "Flow Sensor Calibration" for more information.

4.7.8 System

The [**System**] menu is accessible only by authorized administrative service personnel with password access. The [**System**] menu can only be accessed in Standby mode.

NOTE: **The authorized administrator should change the default password immediately after the system is installed to prevent unauthorized access to the System menu. The password may contain up to 30 digits including numbers, letters (case sensitive) and special characters.**

4.7.8.1 Calibrate



Figure 4-38 Setup > System > Calibrate menu

MENU	DESCRIPTION
O₂ sensor	Select [Begin] to calibrate the O ₂ sensor and follow the prompts on the screen. See (Pages 9-4) 9.4 "O ₂ Sensor Calibration".
Zero Flow Meters	Select [Begin] to zero the flowmeter and follow the prompts on the screen. NOTE: Before zeroing the flowmeter, make sure that the gas supply (O₂, N₂O and air) is disconnected.
Zero HFNC	This menu shows when you configure the HFNC function. Select [Begin] to zero the HFNC module and follow the prompts on the screen.
AG module	This menu shows when you configure the AG module. See (Pages 7-11) 7.11 "Calibrate the AG Module".
Internal AG module	This menu shows when you configure the internal AG module. See (Pages 7-11) 7.11 "Calibrate the AG Module".

Table 4-6 Calibrate menu

4.7.8.2 Setup

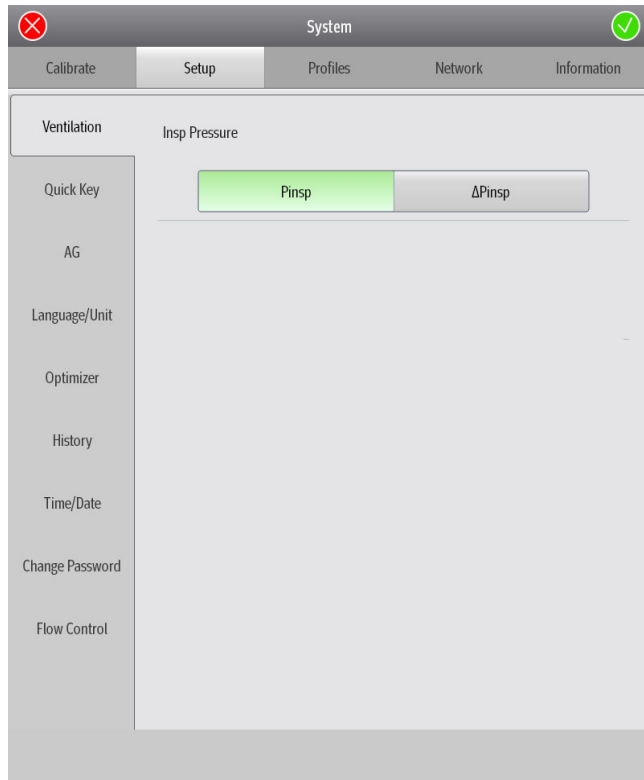

Figure 4-39 Setup > System > Setup menu

MENU	OPTION	DESCRIPTION
Ventilation	Insp Pressure	When [Insp Pressure] is set to [Pinsp], the inspiration pressure parameter in the PCV and SIMV-PCV ventilation modes is [Pinsp]. When [Insp Pressure] is set to [ΔPinsp], the inspiration pressure parameter in the PCV and SIMV-PCV ventilation modes is [ΔPinsp].

Table 4-7 Setup menu

MENU	OPTION	DESCRIPTION
	Alarm Reset	When the [Alarm Reset] is enabled, the Main Screen will display the [Alarm Reset] soft key. When the [Alarm Reset] is disabled, the Main Screen will not display the [Alarm Reset] soft key.
	Capture Event/Screen	When the [Capture Event/Screen] is enabled, the Main Screen will display the [Capture Event/Screen] soft key. When the [Capture Event/Screen] is disabled, the Main Screen will not display the [Capture Event/Screen] soft key.
Quick Key	Lung Recruitment (Optional)	When the [Lung Recruitment] is enabled, the Main Screen will display the [Lung Recruitment] soft key. When the [Lung Recruitment] is disabled, the Main Screen will not display the [Lung Recruitment] soft key.
	Flow Pause	When the [Flow Pause] is enabled, the Main Screen will display the [Flow Pause] soft key. When the [Flow Pause] is disabled, the Main Screen will not display the [Flow Pause] soft key.
	Bypass in Auto mode	When the feature is enabled, the [Bypass] soft key on the Main Screen is available in both the Auto Ventilation mode and Manual Ventilation mode. When the feature is disabled, the [Bypass] soft key is only available in the Manual Ventilation mode.
AG (AG module configured)	Null for 30s from zeroing	When the feature is enabled, related parameters of AG module will be invalid within 30s of starting zeroing AG module. When the feature is disabled, related parameters of AG module will be normal within 30s of starting zeroing AG module.
	Types of Agent	Set the types of anesthetic agent which need automatic recognition.
	Language	Sets the user interface text language.
	Pressure Unit	Sets the unit for pressure.
	CO₂ Unit	Sets the unit for CO ₂ .
Language/Unit	Gas Supply Pressure	Sets the unit for the gas supply pressure.
	Agent Cost Unit	Sets the agent cost unit.
	Patient Height	Sets the unit for patient height.
	Patient Weight	Sets the unit for patient weight.
	Optimizer	Enables or disables the OPTIMIZER [®] feature.
Optimizer	Agent Usage	Enables or disables the agent usage calculation feature.
	Cost/ml of Liquid Agent	Sets the cost of anesthetic agent per ml.
History	Clear History	Configure the Clear History setting at the end of the case. When this feature is enabled, the standby screen displays the [Clear History will delete all List Trends and Event Logs at the start of case!].

Table 4-7 Setup menu

MENU	OPTION	DESCRIPTION	
Time/Date	24 Hour Time	Enables or disables the 24 Hour Time.	
	Time Zone	Selects to set the UTC time zone.	
	Time	Sets the current time.	
	Date Format	Sets the date format.	
	Date	Sets the current date.	
	Daylight Savings	The [Daylight Savings] can be set to [Auto] , [On] or [Off] . When the [Daylight Savings] is set to [Auto] , the start time and end time of the daylight savings should be set. When the [Daylight Savings] is set to [On] , the system time is automatically adjusted. If the region or country where the equipment is installed does not observe the daylight savings, set the [Daylight Savings] to [Off] .	
	Start	Sets the start time of [Daylight Savings] . If the [Daylight Savings] is set to [On] or [Off] , this setting cannot be selected.	
	End	Sets the end time of [Daylight Savings] . If the [Daylight Savings] is set to [On] or [Off] , this setting cannot be selected.	
	Change Password	Current Password	Changes the system password. The authorized administrator should change the default password immediately after the system is installed to prevent unauthorized access to the System menu. The password may contain up to 30 digits including numbers, letters (case sensitive) and special characters.
		New Password	
Confirm Password			
Flow Control	Quick Key 1	The quick key for the [Fresh Gas Control] menu can be set here. The option can also be used to set the flow rate and O ₂ concentration.	
	Quick Key 2		
	Quick Key 3		
	Quick Key 4		
	Total Flow	Select to set the default fresh gas total flow when coming out of standby.	

Table 4-7 Setup menu

4.7.8.3 Profiles

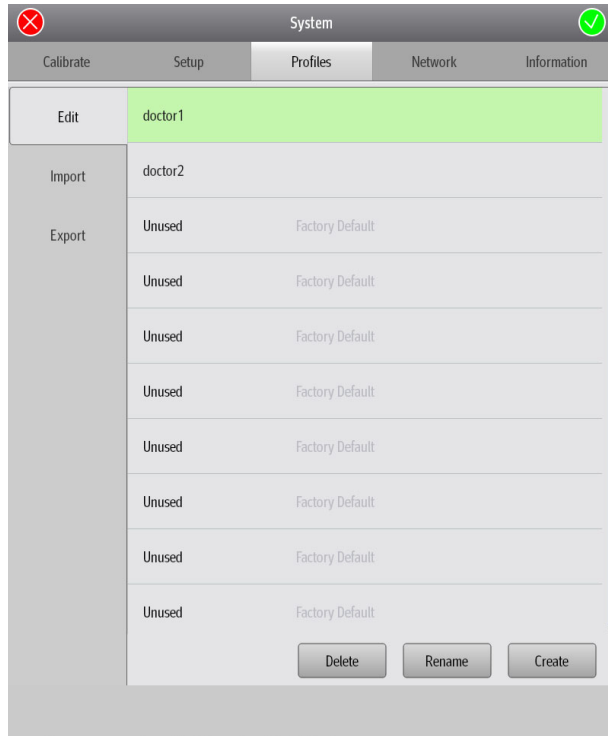

Figure 4-40 Setup > System > Profiles menu

MENU	OPTION	DESCRIPTION
	Delete	10 factory profiles are displayed by default. In practical application, the operator may make some changes to some settings and these changes can be saved as user profiles. The anesthesia system saves the profiles in real time and the saved profiles are called recent profiles.
	Rename	
		<p>Save User Profile: Select the [Create] soft key to set the profile name on the pop-up screen. After the profile is confirmed, the system will save the current profile as a user profile.</p> <p>Restore Factory Profile: Select a user profile, and select the [Delete] soft key. The system will delete the user profile and restore the factory profile.</p>
Edit	Create	<p>Load Profile Manually:</p> <ul style="list-style-type: none"> In the standby mode, select the [Current Profile: xxxx] soft key and select the desired profile on the pop-up screen. Select the [Manual] ventilation mode, and select the [Load Profile] soft key on the pop-up screen, and then select the desired profile on the pop-up screen. <p>When the anesthesia system restarts within 60 seconds after an power outage, the system can automatically restore the recent profile. If the power outage lasts longer than 120 seconds, the anesthesia system will automatically load the user profile before the shutdown. If the power outage lasts between 60 to 120 seconds, the anesthesia system may automatically restore the recent profile or automatically load the user profile before the shutdown.</p>
Import	/	Insert a USB storage device into the SB interface of the anesthesia system and import the profile duplicate from the USB storage device as per the prompts on the screen.
Export	/	Insert a USB storage device into the SB interface of the anesthesia system and export the profile duplicate to the USB storage device as per the prompts on the screen.

Table 4-8 Profiles menu

4.7.8.4 Network

The screenshot shows the 'System' configuration window with the 'Network' tab selected. The window has a title bar with a red 'X' on the left and a green checkmark on the right. Below the title bar are five tabs: 'Calibrate', 'Setup', 'Profiles', 'Network', and 'Information'. The 'Network' tab is active, displaying a list of network settings. The settings are organized into sections: Ethernet1, Serial, HL7, MD2, SNTP, ADT, and Optimizer Source. Each setting has a label, a value, and an edit icon (pencil) or a toggle switch.

Section	Setting	Value	Action
Ethernet1	MAC Address	30:9C:23:51:D9:D5	
Serial	Device Name	Please Input	✎
	Obtain IP Address Automatically	<input type="checkbox"/>	
MD2	IP Address	192 . 168 . 23 . 250	✎
SNTP	Subnet Mask	255 . 255 . 255 . 0	✎
ADT	Default Gateway	0 . 0 . 0 . 0	✎
Optimizer Source	Obtain DNS Server Address Automatically	<input type="checkbox"/>	
	Preferred DNS Server	0 . 0 . 0 . 0	✎
	Alternate DNS Server	0 . 0 . 0 . 0	✎

Figure 4-41 Setup > System > Network menu

MENU	OPTION	DESCRIPTION
Ethernet	MAC Address	Displays the MAC address of the anesthesia system.
	Device Name	Sets the device name.
	Obtain IP Address Automatically	Enables or disables the Obtain IP Address Automatically feature. When the feature is enabled, the [IP Address], [Subnet] and [Default Gateway] cannot be manually changed. When the feature is disabled, the [IP Address], [Subnet] and [Default Gateway] need to be manually changed. In this case, the Obtain DNS Server Address Automatically and Obtain Default DNS Suffix Automatically features, and the Obtain IP Address Automatically feature in the SNTP menu are disabled.
	IP Address	Sets the IP address.
	Subnet Mask	Sets the subnet mask.
	Default Gateway	Sets the default gateway.
	Obtain DNS Server Address Automatically	Enables or disables the Obtain DNS Server Address Automatically feature. When the feature is enabled, the [Preferred DNS Server] and [Alternate DNS Server] cannot be manually changed. When the feature is disabled, the [Preferred DNS Server] and [Alternate DNS Server] need to be manually changed.
	Preferred DNS Server	Sets the preferred DNS server.
	Alternate DNS Server	Sets the alternate DNS server.
	Serial	Protocol
Baud Rate		Sets the Baud rate.
Data Bits		Sets the data bits.
Stop Bits		Sets the stop bits.
Parity		Sets the parity.
Data Interval		Sets the data intervals.
HL7 Protocol Version		Sets the HL7 protocol version.
Compatibility		Sets the serial communication protocol version.
Send Alarms		Enables or disables the Send Alarms feature.
Send Alarm Ack		Enables or disables the Send Alarm Ack feature.

Table 4-9 Network menu

MENU	OPTION	DESCRIPTION	
HL7	Data+ Waveforms	Destination IP	Sets the destination IP address.
		Port	Sets the port.
		Test Results	Select the [Test] soft key, and the system will start the network test and display the test results.
		Data Interval	Sets the data intervals.
		HL7 Protocol Version	Sets the HL7 protocol version.
		Compatibility	Sets the serial communication protocol version.
		Send Waveforms	Enables or disables the Send Waveforms feature.
	Alarm	Destination IP	Sets the destination IP address.
		Port	Sets the port.
		Test Results	Select the [Test] soft key, and the system will start the network test and display the test results.
		HL7 Protocol Version	Sets the HL7 protocol version.
		Compatibility	Sets the serial communication protocol version.
		Send Alarms	Enables or disables the Send Alarms feature.
		Send Alarm Ack	Enables or disables the Send Alarm Ack feature.
Receiving Setting	Receiving Application	Input the receiving application.	
	Receiving Facility	Input the receiving facility.	
MD2	EUI	Displays the EUI mark.	
	MD2	Enables or disables the MD2 protocol channel. When MD2 protocol channel is enabled, the [Destination IP] cannot be manually changed. When MD2 protocol channel is disabled, the [Destination IP] needs to be manually changed.	
	Destination IP	Sets the destination IP address.	
	Test Results	Select the [Test] soft key, and the system will start the network test and display the test results.	
	Local Certificate	Displays the local certificate according to the [Certificate Type]. The local certificate can be deleted.	
Certificate Management	Import Certificate	To import a certificate, do as follows: <ol style="list-style-type: none"> 1. Create a folder named "TLSCerts" in the U disk. 2. Copy the certificate to the "TLSCerts" folder. 3. Insert the U disk into the SB interface of the anesthesia system. 4. Set the [Certificate Type]. 5. Set the [Certificate Name], [Private Key Name] or [Private Key Password]. 6. Select the [Import] soft key. 	

Table 4-9 Network menu

MENU	OPTION	DESCRIPTION
SNTP	Interval	Sets the time interval.
	Primary Server IP Address	Sets the primary Server IP address.
	Secondary Service IP Address	Sets the secondary server IP address.
	Test Results	Select the [Test] soft key, and the system will start the network test and display the test results.
ADT	ADT	Enables or disables the ADT feature.
	Destination IP	Sets the destination IP address.
	Port	Sets the port.
	Test Results	Select the [Test] soft key, and the system will start the network test and display the test results.
Optimizer Source	IP Address	Sets the IP address.
	Multicast Address	Sets the multicast address.
	Test Results	Select the [Test] soft key, and the system will start the network test and display the test results.

Table 4-9 Network menu

4.7.8.5 Information

Displays the equipment ID, MAC address and system features status.

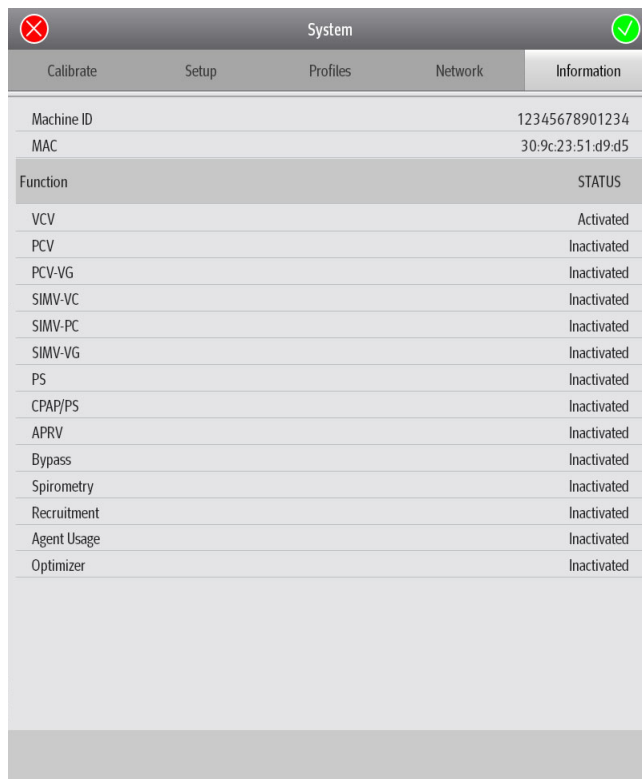

System	
Function	STATUS
Machine ID	12345678901234
MAC	30.9c:23:51:d9:d5
VCV	Activated
PCV	Inactivated
PCV-VG	Inactivated
SIMV-VC	Inactivated
SIMV-PC	Inactivated
SIMV-VG	Inactivated
PS	Inactivated
CPAP/PS	Inactivated
APRV	Inactivated
Bypass	Inactivated
Spirometry	Inactivated
Recruitment	Inactivated
Agent Usage	Inactivated
Optimizer	Inactivated

Figure 4-42 Setup > System> Information menu

4.7.9 Service Tab

Accessible only by Mindray-authorized service personnel. Please contact Mindray Technical Support for assistance.

4.8 Status Screen

4.8.1 Volume Exchanger

The Status Screen does not display the volume exchanger when in standby, ACGO and Monitor modes.

4.8.1.1 Automatic Ventilation, Flow Pause or Bypass

The system provides a VTi loop and dynamic lung to indicate the operation status of the volume exchanger during ventilation.

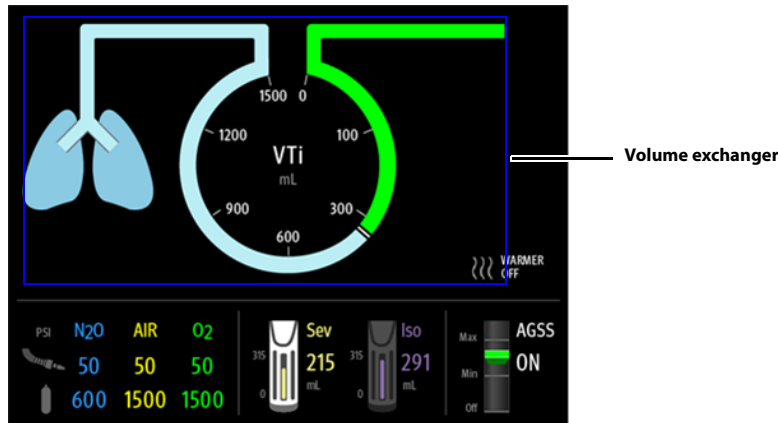

Figure 4-43 Volume exchanger (in automatic ventilation, flow pause or Bypass mode)

4.8.1.2 Manual Ventilation

The system provides a dynamic bag and dynamic lung to indicate the ventilation status.

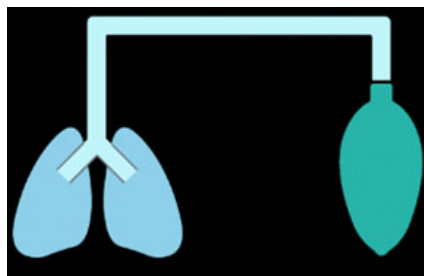

Figure 4-44 Manual Ventilation Mode

4.8.2 Gas Supply Pressure Monitoring

The anesthesia system monitors the gas supply pressure electronically. When the gas supply pressure triggers an alarm, the pressure value on the screen flashes and is highlighted in the color matching the alarm priority.

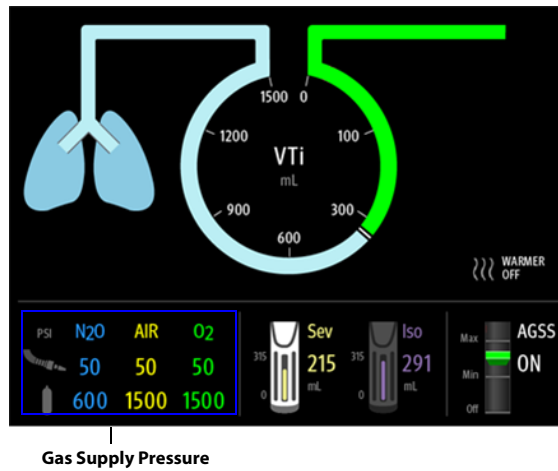



Figure 4-45 Gas supply pressure monitoring

To change the gas supply pressure unit, perform the following settings:

1. Select the  soft key > **[System]** soft key (system password required) > **[Setup]** > **[Language/Unit]** tab.
2. Set **[Gas Supply Pressure]** to **[kPa]**, **[psi]** or **[bar]**.

4.8.3

Vaporizer

When the system detects a vaporizer, it displays the status and agent volume of the vaporizer.

- When the vaporizer is in use the vaporizer image on the status screen is highlighted.
- When the vaporizer is turned off, the vaporizer image on the status screen turns gray.
- When the vaporizer triggers a **[Vaporizer Liquid Level Low]** or **[Vaporizer Almost Empty]** alarm, the agent volume on the screen flashes and is highlighted in the color matching the alarm priority.
- When the vaporizer triggers other alarms, the border of the vaporizer turns to the color matching the alarm priority.

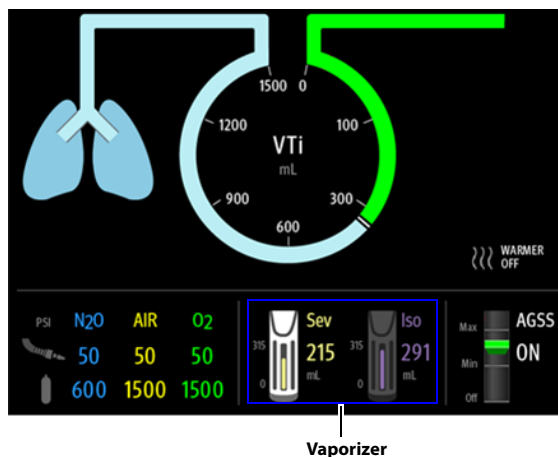

Figure 4-46 Vaporizer

4.8.4 AGSS

The AGSS status is displayed when the system is configured with AGSS. The float is used to indicate the AGSS flow rate. Rotate the knob clockwise or anticlockwise the AGSS flow control knob until the float in the Status Screen is located between Min and Max scale lines. When the system enters the standby status, the AGSS is off and the float is in the [Off] status.

NOTE: Read the AGSS flow rate based on the position of the upper surface of the float.

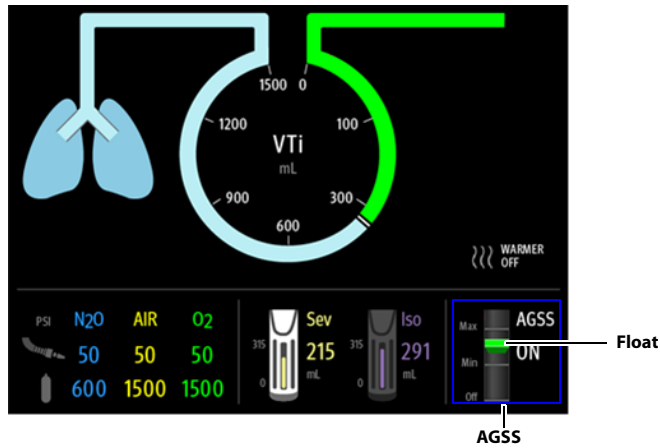

Figure 4-47 AGSS

Preoperative Tests

Requirements of Preoperative Tests	5-2
Preoperative Checklist	5-3
Inspect the System	5-5
System Check.....	5-6
Power Failure Alarm Test	5-7
Pipeline Test.....	5-7
Basic Ventilation Test.....	5-9
Backup Gas Cylinder Test.....	5-9
Flow Control System Test.....	5-10
Breathing System Test	5-12
Alarm Test.....	5-13
Inspect the AGSS.....	5-16
Check Passive AGSS.....	5-16
Inspect the Negative Pressure Suction Device	5-16
Pre-operation Preparations	5-16

5.1 Requirements of Preoperative Tests

Preoperative tests on the equipment follow the ASA guidelines and should be performed according to the test intervals listed below. Refer to special procedures or precautions in this manual.

NOTE: This is a guideline which can be modified to accommodate variations in local clinical practice. Such local modifications should have appropriate peer review.

NOTE: Ensure that the N₂O cutoff and O₂/N₂O ratio are normal before use. Use an O₂ concentration tester to monitor the O₂ concentration in the gas output.

Perform the preoperative tests listed below at these events:

- **After the equipment is repaired or maintained, all test items should be tested.**
- **Every day before the equipment is used on the first patient:**
 - Inspect the System (Section 5.3)
 - System Check (Section 5.4)
 - Power Failure Alarm Test (Section 5.5)
 - Pipeline Test (Section 5.6)
 - Basic Ventilation Test (Section 5.7)
 - Backup Gas Cylinder Test (Section 5.8)
 - Flow Control System Test (Section 5.9)
 - Breathing System Test (Section 5.10)
 - Alarm Test (Section 5.11)
 - Inspect the AGSS (Section 5.12)
 - Inspect the Negative Pressure Suction Device (Section 5.14)
 - Pre-operation Preparations (Section 5.15)
- **Before using the equipment on each patient:**
 - Inspect the System (Section 5.3)
 - System Check (Section 5.4)
 - Pipeline Test (Section 5.6)
 - Breathing System Test (Section 5.10)
 - Inspect the AGSS (Section 5.12)
 - Inspect the Negative Pressure Suction Device (Section 5.14)
 - Pre-operation Preparations (Section 5.15)

NOTE: Read and understand the operation and maintenance of each component before using the anesthesia system.

NOTE: Do not use the anesthesia system if a test failure occurs. Please contact Mindray Technical Support for any additional assistance.

NOTE: Provide a checklist of the anesthetic system, including anesthetic gas delivery system, monitoring device, alarm system, and protective device, which are intended to be used for the anesthetic system, whether they are used alone or assembled together.

5.2 Preoperative Checklist

5.2.1 Introduction

The purpose of preoperative check is to detect potential system problems before use.

An effective method for detecting pneumatic circuit occlusions, leaks, and other system problems can be found in the procedures of preoperative checks. In addition, it is recommended that the breathing circuit be tested for the ability to effectively deliver positive pressure ventilation before each ventilation begins. Test to see if the test lung can be properly ventilated and quickly identify an occluded circuit limb and other breathing circuit problems.

5.2.2 Suggested Preoperative Checklist

WARNING: To ensure the normal operation of the system and the safety of both the user and the patient, please follow all check procedures established by the hospital before administering anesthesia to the patient.

Each day before administering anesthesia, the following should be done:

1. With the anesthesia system connected to an AC power supply, turn on the power switch and verify that the system is powered by the AC power supply. Follow the on-screen prompts to perform and complete the start-up test.
2.
 - a. Check the O₂ Supply Failure safety messages and alarms.
(See "O₂ Pipeline Test" on Pages 5-7)
 - b. Test low O₂ concentration alarms.
(See "O₂ Concentration Monitoring and Alarm Test" on Pages 5-13)
 - c. Test high and low airway pressure alarms.
(See "Airway Pressure (Paw) Too High Alarm Test" on Pages 5-15)
(See "Airway Pressure (Paw) Too Low Alarm Test" on Pages 5-15)
 - d. Test low minute ventilation and apnea alarms.
(See "Minute Volume (MV) Too Low Alarm Test" on Pages 5-14)
(See "Apnea Alarm Test" on Pages 5-14)
3. Verify that the O₂ sensor displays approximately 21% in room air and above 94% after exposure to 100% O₂ (See "O₂ Concentration Monitoring and Alarm Test" on Pages 5-13).
4. Check whether the vaporizer has been properly installed and sufficiently filled.
5. For an anesthesia system equipped with an AGSS, check whether the AGSS float position is between the Min and Max scale lines ("Inspect the AGSS" on Pages 5-16).
6. Drain any moisture from the breathing system water trap.
7. Drain and wipe with a soft cloth any moisture from the absorber canister assembly.

Prior to administering anesthesia to each patient, the following should be done:

1. Check for any damage to or dangerous conditions in the equipment. Ensure all necessary equipment and supplies are present, e.g., drugs, CO₂ absorbent (not exhausted), breathing circuits and backup O₂ supply.
2. Check that the central O₂, N₂O and air supply pressure is within the specified range for pipelined gas supply (i.e., 280 -600 kPa (40 to 87 psi)).
3. Perform the flow control system test (See "Flow Control System Test" on Pages 5-10).
4. Verify that the O₂ and air supplies of HFNC are available and functioning.
5. Verify that the Self-inflating Manual Ventilation device is available and functioning.
6. Check whether the backup O₂, N₂O and air cylinders (if applicable) have been installed onto the equipment and whether they have sufficient pressure without leakage under high pressure. (See "Test Backup Gas Cylinders" on Page 4-12)
7. Check whether the valves of the backup O₂, N₂O and air cylinders (if applicable) have been closed and not opened until needed to prevent unexpected use.
8. Connect the breathing circuit and manual bag and check the operation of unidirectional valves by visual inspection.
9. Check the ventilation capability in Standby, Manual, VCV and PCV modes.
10. Check that patient suction is adequate to clear the airway.
11. Verify the monitoring functionality and check alarms.

The following step is recommended to be performed when prompted by the equipment:

- Complete the 21% of O₂ calibration (See "O₂ Sensor Calibration" on Pages 9-4).

The following step is recommended when replacing an O₂ sensor:

- Complete the 21% and 100% of O₂ calibration (See "O₂ Sensor Calibration" on Pages 9-4).

The following steps are recommended for each installing of new vaporizers or each replacement of CO₂ absorbent:

- Perform a vaporizer test (See "Vaporizer Test" on Pages 5-7).

5.3 Inspect the System

NOTE: Ensure that the breathing system is correctly connected and not damaged.

Perform the following inspections before operating the equipment:

1. The equipment is correctly connected and it is in good condition.
2. Inspect the system for:
 - a. Damage to flowmeters, vaporizers, gauges, supply hoses.
 - b. Complete breathing system with adequate CO₂ Pre-Pak absorbent or loose fill CO₂ absorbent.
 - c. Backup gas cylinders are properly installed onto the yokes.
 - d. Wrenches of backup gas cylinders are in place.
 - e. O₂ supply of HFNC is available and functioning.
3. All components are correctly attached.
4. The breathing system is correctly connected, the breathing tubes are undamaged. The self-inflating manual ventilation device is available and functioning.
5. The gas supply system has been connected and the pressure is correct.
6. The necessary emergency equipment is available and in good condition.
7. Equipment for airway maintenance and tracheal intubation is available and in good condition.
8. Inspect the color of the soda lime in the canister. Replace the soda lime immediately if obvious color change is detected.

WARNING: Check if the gasket is properly installed in place while installing the canister. If the gasket is not properly installed (for example, gasket is not centered), it may cause breathing system leakage.

WARNING: Before locking the canister, make sure that the gasket on the bypass assembly and the canister edge have no residual absorbent particles or powder. Otherwise it may cause breathing system leaks.

9. Applicable anesthetic and emergency drugs are available.
10. The casters are not damaged or loose, the brake(s) is set and prevents movement.
11. Ensure that the breathing system is in proper position.
12. The AC mains indicator turns on when the power cord is connected to the AC power source. If the indicators are not displayed, the system does not have electrical power.
13. The anesthesia system can be switched on or off normally.
14. The O₂ Flush button is functioning properly.

5.4 System Check

1. *From system being turned on:*
When the system is turned on, it automatically initiates the Power On Self Test (POST). After the POST is over, the system check screen is displayed.





Alternatively, on the *Main Screen*:

Enter the standby screen, select the  soft key > **[System Check]** soft key, and enter the system check screen.

2. Follow the instructions on the Main Screen for operations.
3. Select the **[Continue]** soft key and the system starts the check.
4. Select **[Test Details]** to view the test results of each test item.
5. You can then proceed to standby or troubleshoot the equipment based on the test results.
6. After the system check is over, the Preoperative Checklist screen is displayed. Perform desired preoperative checks as per the prompts on the screen.

SYSTEM CHECK ITEMS	DESCRIPTION	REMARK
1. Startup	When the system is turned on, it performs a check to ensure its alarm system (alarm LED and speaker) and hardware (flowmeter board, ventilator board, auxiliary ventilator board, power board, and CPU board) are functioning properly.	Confirm that the buzzer plays the check sound when the power on self test is started.
2. System Check	Performs leak and compliance tests, vaporizer tests and AGSS tests. Checks the hardware, valves, sensors, flowmeters, gas supplies, power supplies and modules.	Otherwise, stop using the anesthesia system and contact your service personnel or Mindray.
3. Preoperative Check List	Displays the checks to be performed before operating the system.	

Table 5-1 System Check

NOTE: Select the **[Alarms]** soft key > **[Limits]** tab on the Main Screen. Set the **[AGSS Alarms]** to  (off) or  (on) in the pop-up menu. When the **[AGSS Alarms]** is set to  (on), the System Check items include the AGSS tests. When the **[AGSS Alarms]** is set to  (off), the System Check items do not include the AGSS tests.

5.4.1 Auto System Check

Set the time for the next automatic system check.

1. Enter the standby screen, and select the  soft key > **[Auto System Check]** soft key.
2. Set the time for automatic system checks.
3. Select the **[Start]** soft key and the system enters the standby screen. The time for the next automatic system check is displayed on the standby screen.

5.4.2 Leak & Compliance Test

NOTE: The system records the result of the last Automatic Circuit Leak Test on its standby screen, indicating whether the test was passed, failed, or skipped.

1. *From system being turned on:*
When the system is turned on, it automatically initiates the Power On Self Test (POST). After the POST is over, the system automatically enters the System Check screen. System Check includes leak and compliance tests.

Alternatively, on the *Main Screen*:

Enter the standby screen, and select the  soft key > **[Leak Test]** soft key.

2. Follow the instructions on the screen:
3. Perform corresponding operation according to the test result and help information.

5.4.3 Vaporizer Test

A vaporizer test primarily covers the following items:

- Leak test of the vaporizer
- Self-test of the vaporizer control valve
- Leak and compliance tests of the breathing system

WARNING: During the vaporizer test, the anesthetic agent comes from the fresh gas outlet. Use a safe and approved procedure to remove and collect the agent.

Before the test, ensure that the vaporizers are correctly installed. For detailed steps, see "Vaporizer" on Pages 3-4.

1. Connect the Y-piece on the breathing circuit to the leak test port.
2. Enter the standby screen, and select the **[Vaporizer Test]** soft key.
3. Follow the instructions on the screen for operations.
4. Select the **[Continue]** soft key to start the vaporizer test.
5. If the system fails the vaporizer test, proceed as prompted on the screen.

5.5 Power Failure Alarm Test

1. Set the System switch to the On position.
2. Disconnect the AC mains.
3. Make sure that the AC mains indicator is off. An audible alarm should sound and the alarm **[Battery in Use]** should be displayed on the Main Screen.
4. Reconnect the AC mains.
5. Make sure the audible alarm sound disappears and the AC mains indicator and battery charge indicator are illuminated. The alarm **[Battery in Use]** should not be displayed on the Main Screen.
6. Set the System switch to the OFF position.

5.6 Pipeline Test

5.6.1 O₂ Pipeline Test

1. Connect the O₂ pipeline supply.
2. If the anesthesia system has been configured with backup gas cylinders, turn off the valves of all the backup gas cylinders.
3. Set the System switch to the On position.
4. Set the O₂ flow to 6 L/min.
5. Ensure that the readings of O₂ pipeline pressure gauges are within the range of 280 to 600 kPa (40 to 87 psi).
6. Disconnect the O₂ pipeline supply.
7. As O₂ pressure decreases, the alarms of [**O₂ Supply Failure**] and [**Drive Gas Pressure Low**] should occur.
8. Ensure that the O₂ gauge reading decreases to zero.

5.6.2 N₂O Pipeline Test

NOTE: To perform a N₂O pipeline test, connect the O₂ supply first to enable N₂O flow control.

NOTE: Different from O₂ pipeline supply, when N₂O supply is disconnected, the anesthesia system with no pressure sensor configured will issue no alarms related to N₂O pressure as N₂O pressure decreases.

1. Connect O₂ and N₂O pipeline supplies.
2. If the anesthesia system has been configured with backup gas cylinders, turn off the valves of all the backup gas cylinders.
3. Set the System switch to the On position.
4. Select the soft key in Fresh Gas Flow display zone, and set the [**Control Mode**] on the pop-up screen to [**Direct Flow**].
5. Set [**Balance Gas**] to [**N₂O**].
6. Set the N₂O flow to 6 L/min.
7. Check whether the readings of the N₂O pipeline pressure gauges are within the range of 280 to 600 kPa (40 to 87 psi).
8. Disconnect the N₂O pipeline supply.
9. With the N₂O pressure decreases, the O₂ flow remains unchanged and the N₂O flow becomes zero. Meanwhile, the anesthesia system with a pressure sensor configured will issue the alarm of [**N₂O Supply Failure**].
10. Ensure that the N₂O gauge reading decreases to zero.

5.6.3 Air Pipeline Test

NOTE: Different from O₂ pipeline supply, when air supply is disconnected, the anesthesia system with no pressure sensor configured will issue no alarms related to air pressure as air pressure decreases.

1. Connect the pipelined Air supply.
2. If the anesthesia system has been configured with backup gas cylinders, turn off the valves of all the backup gas cylinders.
3. Set the System switch to the On position.
4. Select the soft key in Fresh Gas Flow display zone, and set the [**Control Mode**] on the pop-up screen to [**Direct Flow**].

5. Set the Balance Gas to AIR.
6. Set the Air flow to 6 L/min.
7. Check that the Air pipeline pressure gauges show 280 to 600 kPa (40 to 87 psi).
8. Disconnect the pipelined Air supply.
9. With the air pressure decreases, the anesthesia system with a pressure sensor configured will issue the alarm of **[Air Supply Failure]**.
10. Ensure that the Air gauge decreases to zero.

5.7 Basic Ventilation Test

1. Attach a breathing circuit and breathing bag.
2. Attach an adult test lung or breathing bag to the patient end of the Y-fitting of the breathing circuit.
3. Set the O₂ flow to 3 L/min and set the N₂O and air flows to zero.
4. Set the ventilator controls according to the following table:

VENTILATOR CONTROLS	VENTILATOR SETTINGS
Patient Size	Adult
Ventilation Modes	PCV
Target Pressure - P_{insp}	20
Respiratory Rate - RR	8
I:E Ratio - I:E	1:2
PEEP - PEEP	0
Inspiratory Rise Time - T_{slope}	0.5

5. Select **PCV** and begin ventilation.
6. Verify that the breathing bag at the patient end of the Y-fitting of the breathing circuit inflates and deflates and that the PLAT monitoring on the display and the PAW gauge reading are consistent with the P_{insp} setting.

5.8 Backup Gas Cylinder Test

NOTE: No backup gas cylinder test is required for an anesthesia system not configured with backup gas cylinders.

5.8.1 Check Cylinder Pressure

1. Set the system switch to the Off position and connect the gas cylinder to check.
2. Open the valve of each gas cylinder using the attached wrench.
3. Make sure that each gas cylinder has adequate pressure. In case of inadequate pressure discovered in any gas cylinder, close the valve for the specific cylinder and replace the cylinder with a fully-inflated one.
 - Input range of O₂ cylinder: 6.9 to 20 MPa (1000 - 2900 psi)
 - Input range of N₂O cylinder: 4.2 to 6 MPa (600 - 870 psi)
 - Input range of air cylinder: 6.9 to 20 MPa (1000 - 2900 psi)
4. Close the valves of all cylinders.

5.8.2 High Pressure Leak Test of O₂ Cylinders

1. Set the system switch to the Off position and disconnect the O₂ pipeline supply.
2. Open the valve of the O₂ cylinder.
3. Record the current pressure of the cylinder.
4. Close the valve of the O₂ cylinder.
5. Record the cylinder pressure after one minute.

If the pressure reduction of the backup gas cylinder exceeds 1.25 MPa (181.3 psi), install a new cylinder gasket. Repeat Steps 1 to 5. If the leak persists, stop using the backup gas cylinder supply system.

5.8.3 High Pressure Leak Test of N₂O Cylinders

1. Set the system switch to the Off position and disconnect the N₂O pipeline supply.
2. Open the valve of the N₂O cylinder.
3. Record the current pressure of the cylinder.
4. Close the valve of the N₂O cylinder.
5. Record the cylinder pressure after one minute.

If the pressure reduction of the backup gas cylinder exceeds 0.5 MPa (72.5 psi), install a new cylinder gasket. Repeat Steps 1 to 5. If the leak persists, stop using the backup gas cylinder supply system.

5.8.4 High Pressure Leak Test of Air Cylinders

1. Set the system switch to the Off position and disconnect the air pipeline supply.
2. Open the valve of the air cylinder.
3. Record the current pressure of the cylinder.
4. Close the valve of the air cylinder.
5. Record the cylinder pressure after one minute.

If the pressure reduction of the backup gas cylinder exceeds 1.25 MPa (181.3 psi), install a new cylinder gasket. Repeat Steps 1 to 5. If the leak persists, stop using the backup gas cylinder supply system.

5.9 Flow Control System Test

WARNING: If N₂O is available and flows through the system during this test, use a safe and approved procedure to collect and remove N₂O gas.

WARNING: Incorrect gas mixtures can cause patient injury. If the O₂:N₂O ratio system does not supply O₂ and N₂O in the correct proportions, do not use the system.

CAUTION: Open the gas cylinder valve slowly to avoid damage to it. Do not rotate the flow control knob hard. If a backup gas cylinder is not used after a backup gas cylinder test, close its valve.

CAUTION: When the electronic flow control system is disabled, the backup flow control system will be enabled. The initial flow of backup flow control system is 1 L/min of O₂. The BFCS display only has a total flowmeter.

CAUTION: Turn the flow control knob of the backup flow control system slowly. To avoid damaging the control valves, do not turn further when the flowmeter reading is out of range. When turning a flow control knob clockwise to decrease flow, the flowmeter should reach 1 L/min before the knob reaches its most clockwise mechanical stop (off) position. Do not turn any further when the knob has reached the off position. Turning a flow control knob counter clockwise increases flow.

The flow control system includes Electronic Flow Control System (hereinafter referred to as EFCS) and Backup Flow Control System (hereinafter referred to as BFCS). Normally, EFCS is used. Perform EFCS and BFCS tests before any case:

1. Connect the pipeline supplies or slowly open the cylinder valves.
2. Set the System switch to the ON position.
3. Select the soft key in Fresh Gas Flow display zone, and set the [Control Mode] on the pop-up screen to [Direct Flow].
4. Set the Balance Gas to AIR.
5. Adjust the Air flow. Make sure that the displayed reading of electronic flowmeter is consistent with the setting.
6. Set [Balance Gas] to [N₂O].
7. Adjust the N₂O flow gradually. Make sure that the O₂ flow increases with the increase of N₂O flow and that the O₂ and N₂O flows are in the proportion of 1 to 3.
8. Set both O₂ flow and N₂O flow to 5 L/min.
9. Turn off the O₂ pipeline supply.
10. Push the [O₂ Flush] button to release the pressure inside the system.
11. Make sure that the technical alarm of [O₂ Supply Failure] appears, and the N₂O flow is zero.
12. Make sure that a N₂O flow value is read and finally stabilized at 5 L/min after the O₂ pipeline supply is turned on.
13. Open the BFCS cover, start the BFCS and make sure that a prompt message of [BFCS in Use] appears.
14. Make a visual check to ensure that the total flowmeter shows a basal flow of approximately 1 L/min.
15. Adjust the Air needle valve. Increase Air flow gradually and make sure that the total flow can rise to more than 10 L/min. Close the Air needle valve.
16. Adjust the O₂ needle valve to increase the O₂ flow gradually and make sure that the total flow can rise to more than 10 L/min. Adjust the flow to 10 L/min.
17. Close the O₂ needle valve.
18. Rotate the O₂ needle valve for half a circle.
19. Close the BFCS cover, and the Main Screen will prompt a menu to confirm disabling the flow control system. Select [Yes] and ensure that the [Manual valves must be closed!] prompt message appears.
20. Close the O₂ needle valve and close the BFCS cover again. The Main Screen prompts a menu to confirm disabling the flow control system. Select [Yes], and the prompt message disappears.
21. Open the BFCS cover and turn the Air needle valve for half a circle.
22. Close the BFCS cover, the system automatically opens the BFCS cover and the Main Screen will prompt a menu to confirm disabling the flow control system. Select [Yes] and ensure that the [Manual valves must be closed!] prompt message appears.
23. Close the air needle valve and close the BFCS cover again. The Main Screen prompts a menu to confirm disabling the flow control system. Select [Yes], and the prompt message disappears.

NOTE: In the event that the BFCS needle valve fails to be closed when you have closed the BFCS cover, the system will prompt [Manual valves must be closed!] if you proceed with other operations. In this case, check if all the needle valves are fully closed.

NOTE: When checking the readings on the total flowmeter, keep your visual angle at the same level of the float. The reading of the scale may vary when viewed at a different angle.

24. Disconnect the pipelined gas supply or close the cylinder valve.

25. Set the System switch to the OFF position.

5.10 Breathing System Test

WARNING: Objects in the breathing system can stop gas flow to the patient. This can cause injury or death. Ensure that there are no test plugs or other objects in the breathing system.

WARNING: Do not use a test plug that is small enough to fall into the breathing system.

5.10.1 Inspiratory and Expiratory Check Valve Tests

1. Ensure that the breathing system is correctly connected and not damaged.
2. Ensure that the check valves in the breathing system are operating normally.
 - a. Check that the inspiratory check valve opens during inspiration and closes at the start of expiration.
 - b. Check that the expiratory check valve opens during expiration and closes at the start of inspiration.

5.10.2 APL Valve Test

1. Enter Standby mode.
2. Set the Auto/Manual switch to the Manual position.
3. Connect the manual bag to the bag arm port.
4. Connect the Y-piece on the breathing circuit to the leak test port.
5. Turn the APL valve control to the 30 cmH₂O position.
6. Press the [O₂ Flush] button to inflate the manual bag.
7. Ensure that the reading on the airway pressure gauge is within the range of 25 cmH₂O to 40 cmH₂O.
8. Turn the APL valve control to the fully open position.
9. Set the O₂ flow to 3 L/min. Turn any other gases off.
10. Ensure that the reading on the airway pressure gauge is less than 5 cmH₂O.
11. Push and hold the [O₂ Flush] button. Ensure that the reading on the airway pressure gauge does not exceed 10 cmH₂O.
12. Set the O₂ flow to zero. Ensure that the reading on the airway pressure gauge does not fall below 0 cmH₂O.

5.11 Alarm Test

Alarms also can be verified by creating an alarm condition on the equipment and verifying the corresponding alarm indicators are present on the anesthesia system.

5.11.1 Prepare for Alarm Tests

1. Connect the test lung or manual bag to the Y-piece of the breathing circuit.
2. Set the Auto/Manual switch to the Auto position.
3. Set the System switch to the ON position.
4. Set the system to Standby mode.
5. Set Patient Size to Adult.
6. Set the ventilator controls as follows:
 - Ventilation mode: VCV
 - Vt: 500 mL
 - RR: 12 bpm
 - I:E: 1:2
 - Tpause: 10%
 - PEEP: 0 cmH₂O
 - Plimit: 30 cmH₂O
7. Set the Auto/Manual switch to the Manual position.
8. Set the O₂ flow to within the range of 0.5 to 1 L/min.
9. Set the Auto/Manual switch to the Auto position.
10. Ensure that:
 - The Main Screen displays the correctly set data. The measured values should be within the tolerances specified in the specifications. (See "Ventilator Specifications", Table 10.11 on Pages 10-21.

5.11.2 O₂ Concentration Monitoring and Alarm Test

NOTE: For the anesthesia system with the Gas module installed, disconnect the sample line from the Y-piece and breathe into it until you see a CO₂ reading on the screen. Then reconnect the sample line to the Y-piece. This will activate the gas module alarms.

1. Set the Auto/Manual switch to the Manual position and exit Standby mode.
2. If the system has an AG module configured with O₂ monitoring functionality available, make sure that the pre-heating of the module has been complete. Keep the sampling port on the watertrap of the AG module facing the air and check the FiO₂ value on the Main Screen to make sure that approximately 21% O₂ is measured in room air. If the system has no AG module configured with O₂ monitoring functionality available or has no AG module configured, make sure that the system is using the O₂ sensor and the O₂ sensor has been calibrated. Remove the O₂ sensor from the breathing circuit, but do not disconnect the cable of the O₂ sensor. After three minutes, check the FiO₂ value on the Main Screen to make sure that the approximately 21% O₂ is measured in room air.
3. On the Main Screen, select the **[Alarms]** soft key > **[Limits]** tab. Set the FiO₂ low alarm limit to 50%.
4. Ensure that a **[FiO₂ Too Low]** alarm occurs.

5. Set the FiO₂ low alarm limit back to a value lower than the measured O₂ value and make sure that the alarm cancels.
6. Install the O₂ sensor back to the breathing system.
7. Select the Alarms soft key and then the Limits tab. Set the FiO₂ high alarm limit to 50%.
8. Connect the manual bag to the manual bag port. Press the **[O₂ Flush]** button to inflate the manual bag. Ensure that the sensor measures 90% O₂ at least.
9. Ensure that a **[FiO₂ Too High]** alarm occurs.
10. Set the FiO₂ high alarm limit to 100% and make sure that the alarm cancels.

5.11.3 Minute Volume (MV) Too Low Alarm Test

1. Connect the test lung or manual bag to the Y-piece of the breathing circuit.
2. Set the ventilation switch to the Auto position.
3. Set the ventilator controls as follows:
 - Ventilation mode: VCV
 - Vt: 500 mL
 - RR: 12 bpm
 - I:E: 1:2
 - Tpause: 10%
 - PEEP: 0 cmH₂O
 - Plimit: 30 cmH₂O
4. On the Main Screen, select the **[Alarms]** soft key > **[Limits]** tab. Set the MV low alarm limit to 15.0 L/min.
5. Ensure that a **[MV Too Low]** alarm occurs after approximately 60 seconds.
6. Select the **[Alarms]** soft key > **[Limits]** tab. Set the MV low alarm limit back to a value lower than the measured MV value and ensure that the alarm cancels.

5.11.4 Apnea Alarm Test

1. Connect the manual bag to the manual bag port.
2. Set the ventilation switch to the Manual position.
3. Turn the APL valve control to set the APL valve to 10 cmH₂O position.
4. Push the **[O₂ Flush]** button to inflate the bag. Squeeze the manual bag to make sure that a complete breathing cycle is displayed on the screen.
5. Stop squeezing the manual bag and wait for more than 30 seconds to ensure that the **[Apnea]** alarm occurs.
6. Inflate and squeeze the manual bag to ensure that the apnea alarm cancels.

5.11.5 Continuous Airway Pressure Too High Alarm Test

1. Connect the manual bag to the manual bag port.
2. Set the O₂ flow to the minimum value.
3. Turn the APL valve control to set the APL valve to 30 cmH₂O position.
4. Set the ventilation switch to the Manual position.
5. Connect the Y piece on the breathing circuit to the leak test port to occlude the patient end of the breathing system.
6. Push and hold the **[O₂ Flush]** button for approximately 15 seconds. Ensure that the **[Continuous Airway Pressure]** alarm occurs.
7. Disconnect the breathing circuit and ensure that the alarm cancels.
8. Reconnect the breathing circuit.

5.11.6 Airway Pressure (Paw) Too High Alarm Test

1. Connect the test lung or manual bag to the Y-piece of the breathing circuit.
2. Set Patient Type to Adult, and start the automatic ventilation.
3. On the Main Screen, select the **[Alarms]** soft key > **[Limits]** tab.
4. Set the lower limit of PEAK alarm to 0 cmH₂O and the upper limit of PEAK alarm to 5 cmH₂O lower than the monitoring of the anesthesia system.
5. Ensure that the **[Paw Too High]** alarm occurs.
6. Set the PEAK high alarm limit to 40 cmH₂O.
7. Ensure that the alarm cancels.

5.11.7 Airway Pressure (Paw) Too Low Alarm Test

1. Connect the test lung or manual bag to the Y-piece of the breathing circuit.
2. Set Patient Type to Adult, and start the automatic ventilation.
3. On the Main Screen, select the **[Alarms]** soft key > **[Limits]** tab.
4. Set the PEAK low alarm limit to 10 cmH₂O.
5. Disconnect the test lung or manual bag from the Y-piece of the breathing circuit.
6. Wait for 20 seconds. Check the alarm area and ensure that the **[Paw Too Low]** alarm occurs.
7. Connect the test lung or manual bag to the Y-piece of the breathing circuit.
8. Ensure that the alarm cancels.

5.11.8 AG Module Alarm Test

1. Install the AG module and see See "AG Measurement Preparation" on Pages 7-6.
2. Remove the gas sampling tube from the anesthesia system and connect the standard gas bag filled with anesthetic gas AA. AA stands for one of the following anesthetic agents: Des (Desflurane), Iso(Isoflurane) and Sev (Sevoflurane).
3. On the Main Screen, select the **[Alarms]** soft key > **[Limits]** tab.
4. Set the EtAA upper limit to be lower than the standard gas concentration.
5. Ensure that the **[EtAA Too High]** alarm appears on the screen.
6. Set the EtAA lower limit to be higher than the standard gas concentration.

7. Ensure that the [EtAA Too Low] alarm appears on the screen.

5.12 Inspect the AGSS

1. Connect to the O₂ supply.
2. Connect the waste gas outlet of the anesthesia system to the EVAC port or the vacuum port of healthcare facility and turn on the waste gas disposal system.
3. Put the anesthesia machine out of standby status. Check whether the float is located between the MIN and MAX scale lines.

NOTE: If the float is located below the MIN line, rotate the flow control knob (rotate the knob counter clockwise to increase the flow, and rotate it clockwise to decrease the flow) to adjust the float position to between the MIN and MAX scale lines.

NOTE: Do not block the AGSS pressure compensation openings during the inspection. If the float fails to move up to above the MIN scale line, possible reasons include the following:

1. The waste gas disposal system is not working or the pump rate is less than the minimum flow value of the active AGSS specification.
2. The drive gas supply pressure is too low to enable the AGSS normally.

5.13 Check Passive AGSS

1. Connect the waste gas outlet of the anesthesia system to the passive AGSS.
2. Seal the Y-piece and install the manual bag. Set the Auto/Manual switch to the Manual position and rotate the APL valve to the SP position.
3. Set the fresh gas flow to 2 L/min and then exit to the standby mode. Observe the changes in airway pressure for one minute and confirm that the airway pressure does not exceed 5 cmH₂O.

5.14 Inspect the Negative Pressure Suction Device

1. Assemble the negative pressure suction device.
2. Occlude the suction tube at the patient end.
3. Turn on the negative pressure pipeline supply.
4. Set the selector switch to REG.
5. Turn the negative pressure adjustment knob to the maximum position and check if the reading on the pressure gauge increases gradually.

5.15 Pre-operation Preparations

1. Ensure that the ventilator parameters and alarm limits are set to applicable clinical levels.
2. Ensure that the system is in Standby mode.
3. Ensure that the equipment for airway pressure maintenance, manual ventilation and tracheal intubation, and applicable anesthetic and emergency drugs are available.
4. Set the ventilation switch to the Manual position.
5. Connect the manual bag to the manual bag port.
6. Turn off all vaporizers.
7. Turn the APL valve control to the SP position to fully open the APL valve.
8. Ensure that the breathing system is correctly connected and not damaged.

WARNING: Before connecting the equipment to the patient, flush the device with O₂ at a flow of 8 L/min for at least two minutes. This removes unwanted mixtures and by-products from the system.

This page intentionally left blank.

Operations

Powering On the Anesthesia System.....	6-2
Powering Off the Anesthesia System.....	6-2
Patient Setup	6-3
O ₂ Sensor Calibration.....	6-4
Set Fresh Gas	6-4
Set Ventilation.....	6-5
Other Features.....	6-17
Start Automatic Ventilation	6-20
Stop Automatic Ventilation	6-21
Relationships of Ventilation Parameters.....	6-21

WARNING: Before using the anesthesia system on the patient, ensure that the system is correctly assembled and in good condition, and that all the tests described in the Preoperative Tests are already completed. In case of test failure, do not use the system. Contact a qualified Mindray service representative to repair the system.

6.1 Powering On the Anesthesia System

1. Connect the pipelined gas supply and backup gas cylinders of the equipment.
2. Connect the power cord to the AC power source. Check that the AC power LED is illuminated.
3. Set the System switch to ON.
4. The Main Screen shows the start-up screen.
5. The alarm LED flashes red, yellow, and cyan once in turn and then a beep is given. This verifies that audible and visual alarms are operational.
6. After several seconds, the system self-test screen is displayed and the equipment runs its system self-test.

6.2 Powering Off the Anesthesia System

The system provides a powering off function with the following features:

- A prompt sound is given when user turns off the system. If the system switch is turned off in Standby mode, the system waits 3 seconds to power off completely.
- If the power switch is turned off in Manual mode or in any of the Automatic ventilation modes, the system will wait 12 seconds until it is completely powered off. In the 12-second power off delay period, the screen will display a 10-second countdown timer. If the equipment is performing Automatic ventilation, the ventilator will continue ventilating the patient in the current ventilation mode.
- The system beeps once every second during the countdown from 10 seconds to 1 second. When the timer turns to zero, a two-second power-off sound is played.
- When the user turns on the equipment during the power off delay period, the countdown timer will disappear, and the anesthesia system will resume its previous state.

NOTE: The delayed power-off feature is not available when the equipment is in the standby mode. The power-off feature is only available when the equipment is in an active ventilation mode.

6.3 Patient Setup

6.3.1 Standby Mode

Some system functions do not work when the system is in the standby mode.

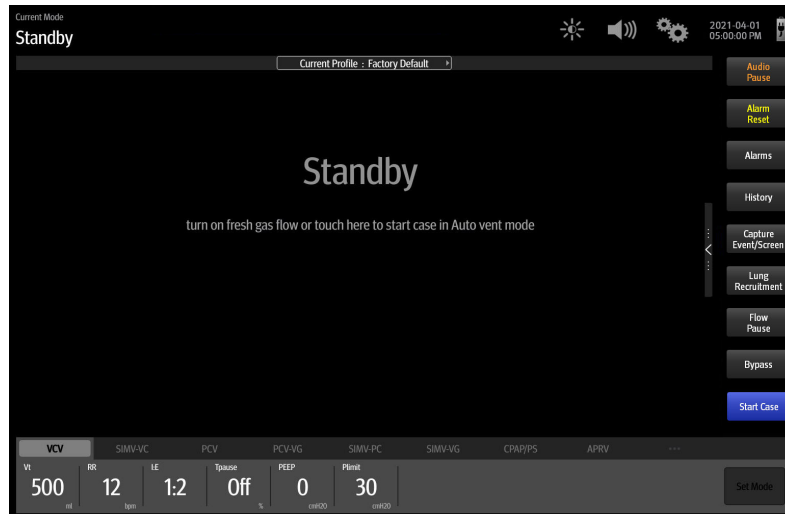

Figure 6-1 Standby Mode

NOTE: Whether to display the [Standby] or [Start Case] key on the soft key field of the Main Screen shall be set by authorized service personnel. Please contact Mindray Technical Support if necessary.

6.3.1.1 Enter Standby mode

When the [Standby] key is displayed on Soft key field of the Main Screen

1. Select the [Standby] key on the Main Screen.
2. Follow the on-screen prompts to enter Standby mode.

When the [Standby] key is not displayed on Soft key field of the Main Screen:

1. Set the Auto/Manual switch to the Manual position.
2. When using the EFCS, skip to Step 3.
When using the BFCS, turn the flow control knob of the BFCS clockwise to the mechanical stop position.
3. Select the [Standby] key in the Manual mode.
4. Follow the on-screen prompts to enter Standby mode.

NOTE: After selecting the [Standby] key, you can set whether to [Restore current profile settings] in the pop-up dialog box.

NOTE: When the system is in Standby mode and the Auto/Manual Switch is in Manual position, the [Bypass] button in the Manual tab is disabled. However, the [Alarms] button remains enabled and can be toggled to On or Off.

WARNING: Entering Standby mode will stop ventilation and parameter monitoring. Do not select Standby mode if the patient requires continuous ventilation.

6.3.1.2 Exit Standby mode

When the **[Start Case]** key is displayed on Soft key field of the Main Screen:

Touch the standby zone or select the **[Start Case]** soft key on the screen, and follow the on-screen prompts to exit the standby mode.

When the **[Start Case]** key is not displayed on Soft key field of the Main Screen:

1. Set the Auto/Manual switch to the Manual position.
2. Touch the waveform zone on the screen or turn on Fresh Gas, or select the **[Start Case]** key, and follow the on-screen prompts to exit standby mode.

6.3.2 Set Patient Information

See 4.2.1 (Pages 4-3) "Patient Information".

6.4 O₂ Sensor Calibration

If O₂ sensor calibration is needed, please see "O₂ Sensor Calibration" on Pages 9-4.

6.5 Set Fresh Gas

6.5.1 Set O₂, N₂O and Air Inputs

You can set the O₂ and balance gas through EFCS, or set the O₂ and air flows through BFCS.

The Security System in the equipment is intended to prevent delivering low-O₂ gas mixtures to patients. N₂O cannot be delivered without O₂.

The equipment maintains a safe O₂ to N₂O ratio by keeping the N₂O flow in a proper ratio to the pre-conditioned O₂ flow. N₂O flow is subject to the limitation of O₂ flow to make sure that O₂ remains in a safe ratio of not lower than 25%.

Auto cut-off of N₂O:

When the O₂ flow rate is lower than 200 mL/min, N₂O is automatically cut off to zero the N₂O flow rate.

O₂ pressure loss alarm:

When the O₂ pressure is lower than 220 kPa (32 psi), the O₂ supply failure alarm is triggered.

O₂ ratio controller:

The O₂ ratio controller ensures that the O₂ concentration in the fresh gas is always not lower than 25% when the N₂O valve is fully opened.

WARNING: If BFCS is used, make sure that both O₂ and air flow controllers are fully closed at the beginning and the end of each case.

NOTE: The float flowmeter is calibrated based on 100% O₂. For other gas, the accuracy of the flowmeter may degrade.

NOTE: When checking the readings on the float flowmeter, keep your visual angle at the same level of the float. The reading of the scale may vary when viewed at a different angle.

NOTE: Before the operation, please confirm the fresh gas control mode is consistent with your habit or preference.

6.5.2 Set Anesthetic Agent

NOTE: You do not need to perform this operation if inspiratory anesthetic agent is not used.

NOTE: The anesthesia system can be installed with vaporizers corresponding with Isoflurane, Sevoflurane and Desflurane. Only one vaporizer can be opened at a time.

6.5.2.1 Select the Desired Anesthetic Agent

1. Determine the anesthetic agent to be used and then fill the vaporizer.

WARNING: Ensure that the correct anesthetic agent is used. The vaporizer is designed with the specific anesthetic agent named on it and further indicated by color coded labeling. The actual output concentration of the anesthetic agent will vary if the vaporizer is filled with the wrong agent.

2. Install the vaporizer filled with anesthetic agent onto the anesthesia system.

6.5.2.2 Adjust the Concentration of Anesthetic Agent

Clicking the vaporizer concentration settings keys in the Fresh Gas Control area to open the dialog box for concentration adjustment.

6.6 Set Ventilation

NOTE: In all ventilation modes, when inspiration pressure reaches the upper limit of PAW alarms, the system switches to expiration immediately and airway pressure is released.

NOTE: In case of a fault with the drive gas supply, the Auto ventilation mode won't function normally.

6.6.1 Change Ventilation Mode

To change ventilation mode to Manual:

Use the Auto/Manual switch on the breathing system to enter and exit Manual ventilation mode.

To change ventilation mode to VCV, SIMV-VC, PCV, PCV-VG, SIMV-PC, SIMV-VG, CPAP/PS, APRV:

1. Select the tab of the desired ventilation mode. The [Set Mode] button (or [Preset Mode] button in manual mode) will flash (Figure 6-2).
2. Select the [Set Mode] button (or [Preset Mode] button in manual mode) to confirm the change. If the [Set Mode] button is not selected after several seconds, an audio reminder will sound for several seconds and then the system will return to the previous ventilation mode.
3. Optionally, select each available ventilation parameter to edit the parameter setting.
4. Move the Auto/Manual Switch to the Auto position.

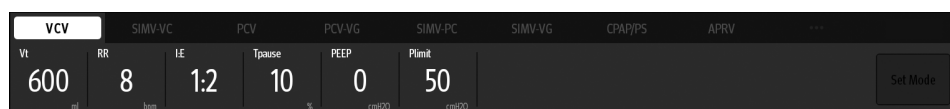

Figure 6-2 Ventilation Mode Tabs

6.6.2 Set Manual Ventilation Mode

Manual ventilation mode is the operating mode used to manually ventilate the patients or allow patients to breathe spontaneously. To use the manual mode, the user must first set the APL valve to the desired pressure value and then use the Auto/Manual switch on the breathing module to enter and exit Manual mode. Push the **[O₂ Flush]** button to inflate the bag if necessary.

Set the APL Valve for Manual Ventilation

Rotate the APL valve adjustment knob to the desired pressure. The number on the knob that lines up with the index mark on the bottom section of the valve indicates the approximate pressure setting.

NOTE: **Clockwise rotation increases the pressure, and counter clockwise rotation decreases the pressure.**

The patient can be ventilated manually using the breathing bag. The pressure will be limited to the value set on the APL valve.

Set the APL Valve for Spontaneous Breathing

Rotate the APL valve adjustment knob fully counter clockwise until the SP marking on the knob lines up with the index mark on the bottom section of the valve. The valve will then be open for the patient to breathe spontaneously.

NOTE: **In the manual ventilation mode, you can use the APL valve to adjust the pressure limit of breathing system and gas volume in the manual bag. When the pressure in the breathing system reaches the pressure limit set for the APL valve, the valve opens to release excess gas.**

NOTE: **The APL valve adjusts the breathing system pressure limit during manual ventilation. Its scale shows approximate pressure.**

Set Alarms

In the manual ventilation mode, when the **[Alarms]** soft key is set to **[Off]**, the pressure, volume and apnea alarms are disabled, and the related alarm limits will be displayed as **[Off]**. Pressure, volume and apnea alarms can be turned on by setting the **[Alarms]** soft key to **[On]**. The related alarm limits will be restored to their original settings.

Set CO₂ Alarms

In the Manual ventilation mode, the CO₂ and the CO₂ apnea alarms can be turned off by setting the **[CO₂ Alarms]** soft key to **[Off]**, and the related alarm limits will be displayed as **[Off]**. The **[CO₂ and CO₂ Apnea Alarms are OFF]** prompt will be displayed in the alarm area. The CO₂ and the CO₂ apnea alarms can be turned on by setting the **[CO₂ Alarms]** soft key to **[On]** or by turning the Auto/Manual switch to the Auto position. The related alarm limits will be restored to their original settings.

NOTE: **In the Auto ventilation mode, the system's CO₂ alarms are turned on by default and cannot be turned off.**

When the system exits the standby mode and enters the Manual ventilation mode, if the **[CO₂ Alarms]** soft key is **[On]**, the system will not enable the CO₂ and the CO₂ apnea alarms until three continuous respiratory waves are monitored.

In the following two cases, the system will disable the CO₂ alarms or CO₂ apnea alarms for 30 seconds. After 30 seconds, the CO₂ and the CO₂ apnea alarms will be enabled even if no respiratory wave has been monitored.

- If the **[CO₂ Alarms]** soft key is set to **[On]** from the **[Off]** status
- Set the Auto/Manual switch from the Manual position to the Auto position

WARNING: Risk of inadequate monitoring. National standards require a minimum monitoring with some basic alarm functions. The standard may not be met if the CO₂ parameter alarms feature is disabled. Please disable the CO₂ parameter alarms feature only after you check the standard.

Anesthetic Gas Purge

While in manual ventilation, select the **[Purge Agent]** soft key and confirm the operation to start the anesthetic gas purge of the breathing system.

6.6.3 Settings Before Starting the Automatic Ventilation Mode

1. Enter Standby mode.
2. Select the desired ventilation mode tab.
3. Set the desired ventilation parameters.
4. Select the **[Set Mode]** key (flashing green) on the right of the ventilation tab to confirm the ventilation mode.
5. If in Standby, exit Standby by touching the Main Screen.
6. To begin automatic ventilation, set the Auto/Manual switch to the Auto position.

6.6.4 Volume Control Ventilation (VCV)

Volume Control Ventilation (VCV) mode is a fully automatic ventilation mode. In the VCV mode, each time automatic ventilation starts, gas is delivered to the patient at a constant flow, which reaches the preset V_t within the gas delivery time. To ensure a certain amount of V_t, the resulted airway pressure (Paw) changes based on patient pulmonary compliance and airway resistance.

In the VCV mode, you need to set the P_{limit} to prevent harm to patients that may be caused by excess airway pressure. Set T_{pause} to improve patient pulmonary gas distribution and PEEP to prevent end-expiratory alveolar collapse and improve hypoxemia.

To ensure the set tidal volume gas delivery, the ventilator adjusts gas flow based on the measured inspiratory volume, dynamically compensating for breathing system compliance and system leakage and eliminating the effect of fresh gas flow as well. This is called tidal volume compensation.

To avoid an excessive amount of gas being delivery due to an incorrect compensation calculation, the compensation calculation has two thresholds.

- 1) The calculated compliance of tube is limited to 5mL/cmH₂O.
- 2) The volume for leakage compensation is limited to 0.5xV_T setting value.

In the VCV mode, if tidal volume compensation fails, the system can continue to deliver gas in a stable manner but cannot compensate for the effects of fresh gas flow and breathing system compliance losses.

In VCV and SIMV-VC modes, when inspiration pressure reaches P_{limit}, respectively, the inspiration pressure is held.

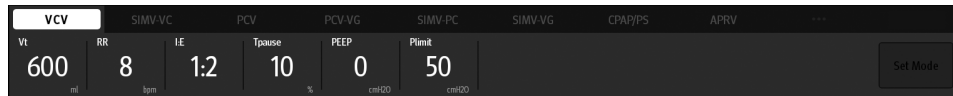

Figure 6-3 Volume Control Ventilation (VCV) Tab

Set VCV Mode:

1. Select the VCV tab on the Main Screen.
2. Select the parameter soft key and assign an appropriate value on the pop-up screen.
3. Check that all VCV parameters are set appropriately.
4. Select the **[Set Mode]** soft key to confirm the settings.

VCV parameters:

- Vt: tidal volume
- RR: respiratory rate
- I:E or Tinsp: ratio of inspiratory time to expiratory time or time of inspiration
- Tpause: percentage of inspiratory pause time in inspiratory time
- PEEP: positive end-expiratory pressure
- Plimit: pressure limit level

NOTE: Before activating a new automatic ventilation mode, ensure that all related parameters are set appropriately.

6.6.5 Set Pressure Control Ventilation (PCV)

Pressure control ventilation (PCV) mode is a basic fully-automatic ventilation mode. In the PCV mode, each time automatic ventilation starts, airway pressure rises rapidly to the preset P_{insp}, then the feedback system will slow down the output flow and maintain a constant airway pressure until the end of the inspiration time. The tidal volume delivered in the PCV mode changes based on patient pulmonary compliance and airway resistance.

In the PCV mode, you can set PEEP to improve expiration of carbon dioxide and to increase oxygenation of breathing process.

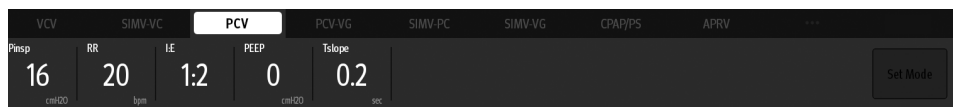

Figure 6-4 Pressure Control Ventilation (PCV) Tab

Set PCV Mode:

1. Select the PCV tab on the Main Screen.
2. Select the parameter soft key and assign an appropriate value on the pop-up screen.
3. Check that all PCV parameters are set appropriately.
4. Select the **[Set Mode]** soft key to confirm the settings.

PCV parameters:

- P_{insp} or ΔP_{insp}: peak inspiratory airway pressure or relative inspiratory pressure.
- RR: respiratory rate

- I:E or T_{insp}: ratio of inspiratory time to expiratory time or time of inspiration
- PEEP: positive end-expiratory pressure
- T_{slope}: rise time

NOTE: Before activating a new automatic ventilation mode, ensure that all related parameters are set appropriately.

6.6.6 Set Pressure Control Ventilation - Volume Guarantee (PCV-VG)

Pressure Control Ventilation - Volume Guarantee (PCV-VG) mode implements volume-guaranteed ventilation in a pressure-controlled manner. In this mode, the pressure level should be kept as low as possible during the inspiratory phase, meanwhile the gas supply volume should be equal to the preset tidal volume. The Pressure control level will vary according to the tidal volume setting, resistance and compliance of the patient's lungs.



Figure 6-5 Pressure Control Ventilation - Volume Guarantee (PCV-VG) Tab

Set PCV-VG Mode:

1. Select the PCV-VG tab on the Main Screen.
2. Select the parameter soft key and assign an appropriate value on the pop-up screen.
3. Check that all PCV-VG parameters are set appropriately.
4. Select the **[Set Mode]** soft key to confirm the settings.

PCV -VG parameters:

- Vt: tidal volume
- Plimit: pressure limit level with volume guarantee
- RR: respiratory rate
- I:E or T_{insp}: ratio of inspiratory time to expiratory time or time of inspiration
- PEEP: positive end-expiratory pressure
- T_{slope}: rise time

NOTE: Before activating a new automatic ventilation mode, ensure that all related parameters are set appropriately.

6.6.7 Synchronized Intermittent Mandatory Ventilation (SIMV)

The equipment supports three modes of SIMV: SIMV-volume control (SIMV-VC), SIMV-pressure control (SIMV-PC) and SIMV-volume guarantee (SIMV-VG).

6.6.7.1 Synchronized Intermittent Mandatory Ventilation–Volume Control (SIMV-VC)

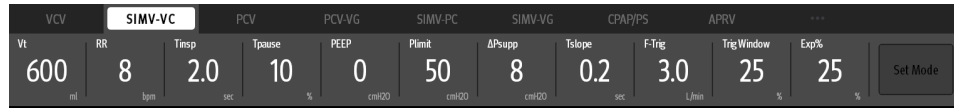

Figure 6-6 Synchronized Intermittent Mandatory Ventilation–Volume Control (SIMV-VC) Tab

SIMV-VC means to deliver synchronized intermittent mandatory volume controlled ventilation to the patient. In the SIMV-VC mode, the ventilator waits for patient's next inspiration based on the specified time interval. The sensitivity depends on Trigger. If Trigger is reached within the trigger waiting time (called synchronous trigger window), the ventilator delivers volume controlled ventilation synchronously with the preset tidal volume and inspiratory time. If the patient does not inspire within the trigger window, the ventilator delivers volume controlled ventilation to the patient at the end of trigger window. Spontaneous breathing outside trigger window can acquire pressure support.

In VCV and SIMV-VC modes, when inspiration pressure reaches Plimit, the inspiration pressure is held.

6.6.7.2 Synchronized Intermittent Mandatory Ventilation–Pressure Control (SIMV-PC)

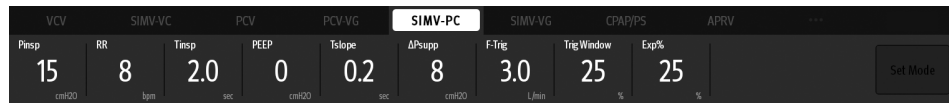

Figure 6-7 Synchronized Intermittent Mandatory Ventilation–Pressure Control (SIMV-PC) Tab

SIMV-PC means to deliver synchronized intermittent mandatory pressure controlled ventilation to the patient. In the SIMV-PC mode, the ventilator waits for patient's next inspiration based on the specified time interval. The sensitivity depends on Trigger. If Trigger is reached within the trigger waiting time (called synchronous trigger window), the ventilator delivers pressure controlled ventilation synchronously with the preset tidal volume and inspiratory time. If the patient does not inspire within the trigger window, the ventilator delivers pressure controlled ventilation to the patient at the end of trigger window. Spontaneous breathing outside trigger window can acquire pressure support.

6.6.7.3 Synchronized Intermittent Mandatory Ventilation–Volume Guarantee (SIMV-VG)



Figure 6-8 Synchronized Intermittent Mandatory Ventilation–Volume Guarantee (SIMV-VG) Tab

SIMV-VG means to deliver synchronized intermittent mandatory pressure control volume guarantee ventilation to the patient. In the SIMV-VG mode, the ventilator waits for patient's next inspiration based on the specified time interval. The sensitivity depends on F-Trig (or P-Trig). If F-Trig (or P-Trig) is reached within the trigger waiting time (called synchronous trigger window), the ventilator delivers pressure controlled volume guarantee ventilation synchronously with the preset tidal volume and inspiratory time. If the patient does not inspire within the trigger window, the ventilator delivers pressure controlled volume guarantee ventilation to the patient at the end of trigger window. Spontaneous breathing outside trigger window can acquire pressure support.

Set SIMV-VC, SIMV-PC or SIMV-VG Mode:

1. Select the SIMV-VC tab, SIMV-PC tab or SIMV-VG tab on the Main Screen.
2. Select the parameter soft key and assign an appropriate value on the pop-up screen.
3. Check that all SIMV-VC, SIMV-PC or SIMV-VG parameters are set appropriately.
4. Select the **[Set Mode]** soft key to confirm the settings.

SIMV-VC parameters:

- Vt: tidal volume
- RR: respiratory rate
- T_{insp}: time of inspiration
- F-Trig/P-Trig: flow rate trigger level/pressure trigger level
- ΔP_{supp}: support pressure
- PEEP: positive end-expiratory pressure
- P_{limit}: pressure limit level
- T_{pause}: inspiratory pause
- Trig Window: trigger window (supports buffer time of synchronous inspiration of patients, in the later expiratory stage in the Auto ventilation mode, with its duration being a percent of the set breathing cycle)
- T_{slope}: rise time
- Exp%: expiration trigger level (change to the expiratory stage when the expiration trigger level (peak flow * expiration trigger level) is reached.)

SIMV-PC parameters:

- P_{insp} or ΔP_{insp}: peak inspiratory airway pressure or relative inspiratory pressure
- RR: respiratory rate
- T_{insp}: time of inspiration
- F-Trig/P-Trig: flow rate trigger level/pressure trigger level
- T_{slope}: rise time
- ΔP_{supp}: support pressure
- PEEP: positive end-expiratory pressure
- Trig Window: trigger window
- Exp%: expiration trigger level

SIMV-VG parameters:

- Vt: tidal volume
- RR: respiratory rate
- T_{insp}: time of inspiration
- F-Trig/P-Trig: flow rate trigger level/pressure trigger level
- ΔP_{supp}: support pressure
- PEEP: positive end-expiratory pressure
- P_{limit}: pressure limit level
- Trig Window: trigger window
- T_{slope}: rise time
- Exp%: expiration trigger level

NOTE: Before activating a new automatic ventilation mode, ensure that all related parameters are set appropriately.

6.6.8 Set Continuous Positive Airway Pressure/Pressure Support Ventilation (CPAP/PS)

In the Pressure Support (PS) mode (when ΔP_{supp} is not 0 cmH_2O , PS is displayed in the current ventilation mode area), the equipment provides support to the patient's effort at a preset inspiratory pressure level. Inspiration is triggered and cycled by patient's effort.

In the Continuous Positive Airway Pressure (CPAP) mode (when ΔP_{supp} is 0 cmH_2O , CPAP is displayed in the current ventilation mode area), the system maintains the airway pressure at the user-defined positive pressure level throughout the ventilation cycle. The patient breathes spontaneously and determines his own breathing frequency, timing and tidal volume.

The user can set the F-Trig (or P-Trig), ΔP_{apnea} , PEEP, Allowed Min RR, and Tslope. If the Min RR (minimum respiratory rate) is exceeded, and there's no spontaneous breathing or spontaneous breathing is too weak to reach F-Trig (or P-Trig), the equipment will give an Apnea Ventilation breath to assure ventilation is occurring.

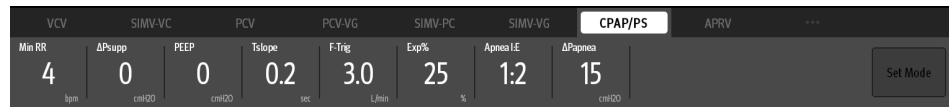

Figure 6-9 Continuous positive airway pressure tab

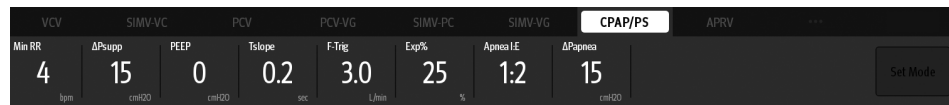

Figure 6-10 Pressure support tab

Set CPAP/PS Mode:

1. Select the CPAP/PS tab on the Main Screen.
2. Select the parameter soft key and assign an appropriate value on the pop-up screen.
3. Check that all CPAP/PS parameters are set appropriately.
4. Select the **[Set Mode]** soft key to confirm the settings.

CPAP/PS parameters:

- ΔP_{supp} : support pressure (the ventilation mode is CPAP when $\Delta P_{\text{supp}}=0\text{cmH}_2\text{O}$)
- Tslope: rise time
- PEEP: positive end-expiratory pressure
- F-Trig/P-Trig: flow trigger level/pressure trigger level
- Exp%: expiration trigger level
- Min RR: minimum respiratory rate, applies to apnea backup breaths only
- ΔP_{apnea} : apnea pressure
- Apnea Ti: apnea inspiration time

NOTE: Before activating a new automatic ventilation mode, ensure that all related parameters are set appropriately.

6.6.9 Set Airway Pressure Release Ventilation (APRV) (Optional)

The APRV mode refers to the Airway Pressure Release Ventilation mode, which can be regarded as the CPAP mode with periodical and transient airway pressure release. APRV applies a continuous positive air way pressure in conjunction with an inverse I:E ratio to assist in maintaining lung inflation may provide benefits to difficult to oxygenate patients.

Switchover between high pressure phase and low pressure phase is based on Tlow and Thigh in APRV mode.

Continuous pressure is allowed in both high pressure phase and low pressure phase.

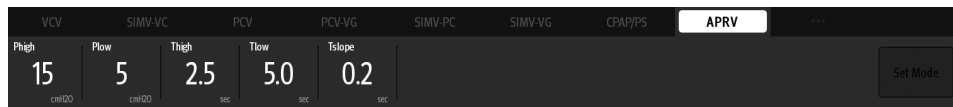

Figure 6-11 Airway Pressure Release Ventilation tab

Set APRV Mode:

1. Select the APRV tab on the Main Screen.
2. Select the parameter soft key and assign an appropriate value on the pop-up screen.
3. Check that all APRV parameters are set appropriately.
4. Select the **[Set Mode]** soft key to confirm the settings.

APRV parameters:

- Phigh: high pressure level
- Plow: low pressure level
- Thigh: high pressure time
- Tlow: low pressure time
- Tslope: rise time

NOTE: Before activating a new automatic ventilation mode, ensure that all related parameters are set appropriately.

6.6.10 Lung Recruitment Ventilation (Optional)

Lung recruitment is a lung-protective ventilation strategy. The ventilator intermittently supplies gases of a pressure higher than the mean airway pressure, and sustains the pressure for a period of time during the automatic ventilation. In this way, the lung recruitment maneuvers open more collapsed pulmonary alveoli and prevent the secondary pulmonary atelectasis caused by the low tidal volumes ventilation.

For the safety of the ventilation and observing the effect of the lung recruitment ventilation, the anesthesia system needs to perform real-time monitoring over PEAK, PEEP, C, and Vte during the lung recruitment ventilation.

NOTE: Recruitment can only be used in automatic ventilation modes.

NOTE: Generally, 100% O₂ or high-concentration O₂ is used for ventilation during lung recruitment.

NOTE: It is not recommended to use lung recruitment where patients may spontaneously breath.

NOTE: Terminate the lung recruitment ventilation when the physiological state of the patient is abnormal.

6.6.10.1 One-Step Recruitment

NOTE: Before activating the lung recruitment ventilation, ensure that all related parameters are set appropriately.

1. On the Main Screen, select the [Lung Recruitment] soft key > [One-Step Recruitment].
2. Set the lung recruitment parameters in the pop-up menu.
3. Select the Start soft key to start the lung recruitment ventilation. [Lung Recruitment] is displayed in the current ventilation mode area.

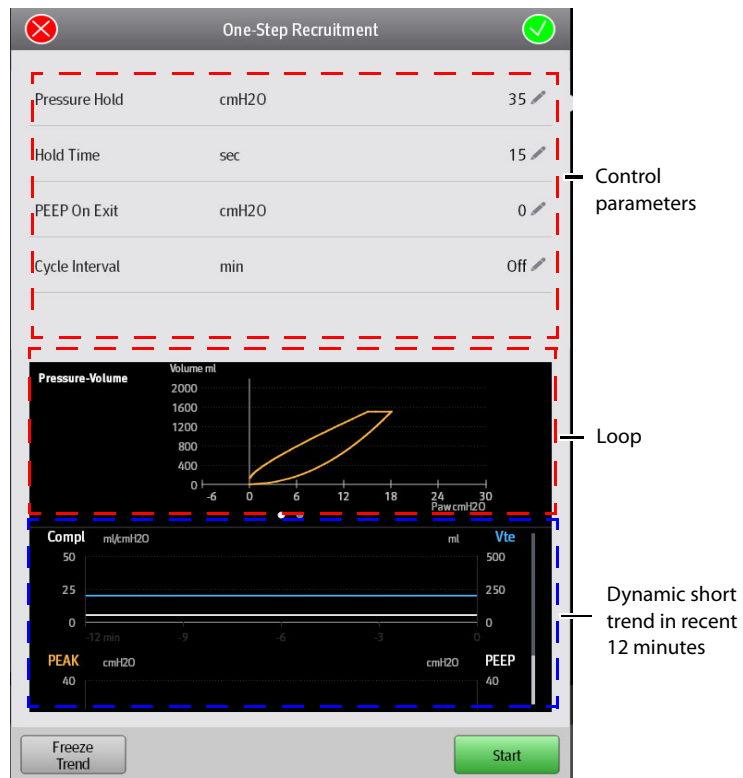

Figure 6-12 One-Step Recruitment

Recruitment parameters:

- Pressure Hold: the lung recruitment ventilation pressure.
- Duration: the lung recruitment ventilation duration.
- PEEP On Exit or Plow On Exit: the positive end-expiratory pressure or low pressure level upon exit from the lung recruitment ventilation mode.
- Cycle Interval: reminds users of the interval of starting lung recruitment ventilation.

6.6.10.2 Multi-Step Recruitment

1. On the Main Screen, select the **[Lung Recruitment]** soft key > **[Multi-Step Recruitment]**.
2. Select **[Procedures]** in the pop-up menu. If necessary, you can edit the current procedure.
3. Select the Start soft key to start the lung recruitment ventilation. **[Lung Recruitment]** is displayed in the current ventilation mode area.

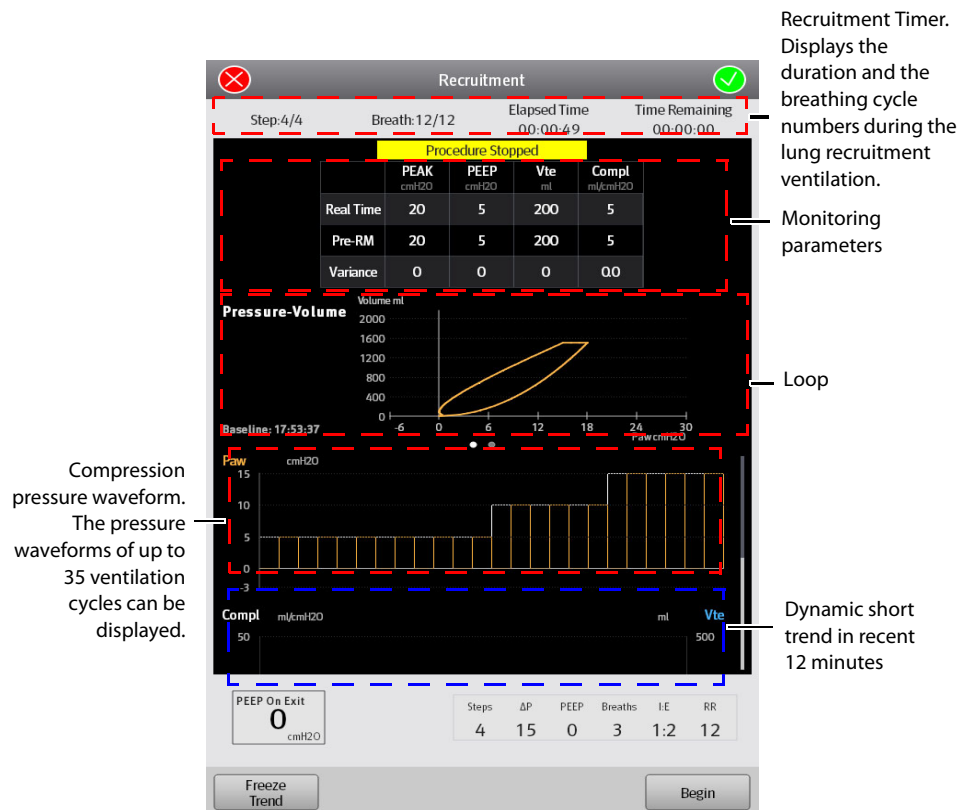

Figure 6-13 Multi-Step Recruitment

Recruitment parameters:

- **Step:** Step of the lung recruitment ventilation. It sets the step number or sets it to off.
- **ΔP:** Support pressure in a certain step of lung recruitment ventilation.
- **PEEP:** Positive end-expiratory pressure in a certain step of lung recruitment ventilation.
- **Breaths:** Breath cycle numbers in a certain step of the lung recruitment ventilation.
- **I:E:** Ratio of inspiratory time to expiratory time in a certain step of lung recruitment ventilation.
- **RR:** Respiratory rate in a certain step of lung recruitment ventilation.
- **PEEP On Exit or Plow On Exit:** the positive end-expiratory pressure or low pressure level upon exit from the lung recruitment ventilation mode.

6.6.10.3 Parameter Monitoring

During the lung recruitment ventilation, the anesthesia system monitors PEAK, PEEP, Vte and Compl in real time.

6.6.10.4 Freeze Trend

Freeze the trend waveforms by selecting the [**Freeze Trend**] soft key in the Recruitment menu.

When trends are in the frozen status, select the [**Unfreeze Trend**] soft key to exit the frozen status.

6.7 Other Features

6.7.1 Auxiliary Common Gas Outlet (ACGO) Mode

If the equipment is configured with an ACGO switch, the system enters or exits ACGO mode by turning on or off the ACGO switch.

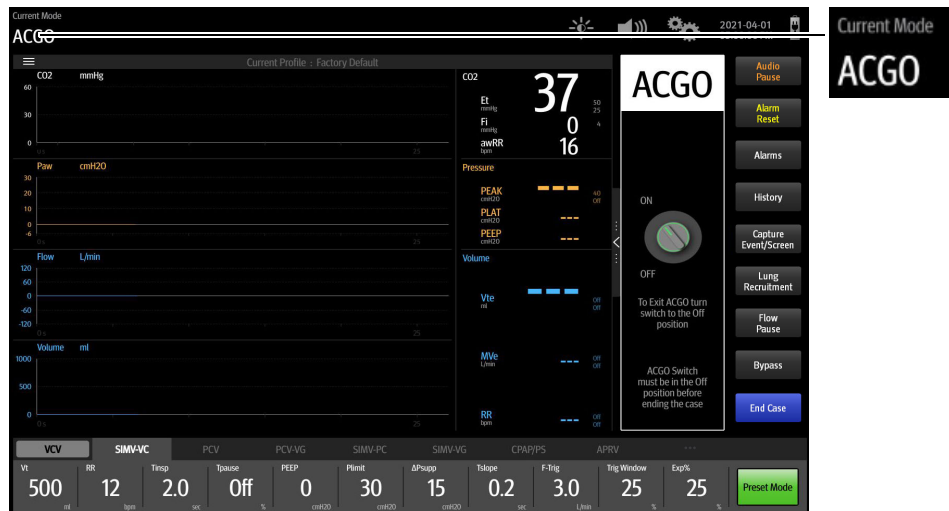

Figure 6-14 ACGO mode

Preset Ventilation Mode after Exit from ACGO

For example, if the current ventilation mode is VCV, enable ACGO and the system will enter the ACGO mode. Under such circumstances:

- If the ventilation mode remains unchanged, the system will enter the VCV mode upon its exit from the ACGO mode.
- If another ventilation mode other than [VCV] has been selected, such as [PCV], select [**Preset Mode**], and the system will enter the PCV mode upon exit from the ACGO mode.

NOTE: If the system is currently in Standby or Manual mode, the system enters ACGO mode when ACGO is enabled. Under such circumstances, the [**Preset Mode**] feature is invalid. At this point, the system will enter the corresponding Standby or Manual mode upon exit from the ACGO mode.

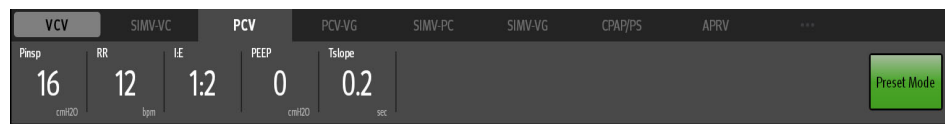

Figure 6-15 Press the [**Preset Mode**] key to set [PCV] as the system's ventilation mode upon exit from the ACGO mode

6.7.2 Monitor

When the anesthesia system has an external AG module configured, the system supports the Monitor mode. In the Manual ventilation mode, select the [**Monitor Mode**] soft key to enable the Monitor mode. [**Monitor**] is displayed in the Current Mode area. The mode disables all ventilation-related alarms.

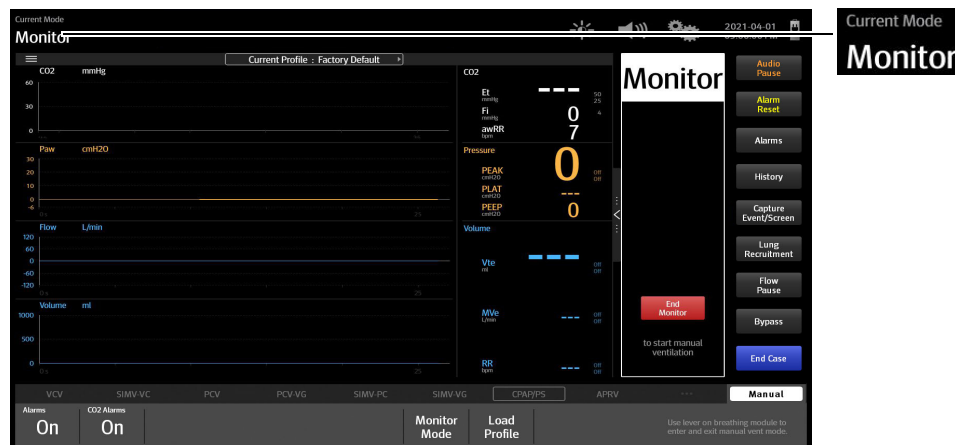







Figure 6-16 Monitor Mode

6.7.3 Cardiac Bypass Mode

The Bypass mode turns off pressure, volume and apnea alarms when they are not appropriate (e.g., during heart/lung bypass).

Set whether to enter the Bypass mode in the automatic ventilation mode:

1. Enter Standby mode.
2. Select the  icon > [System] soft key > enter the system password and confirm the password > [Setup] tab > [Quick Key] tab.
3. Set the [Bypass in Auto mode] to  (off) or  (on).
 - When the [Bypass in Auto mode] is set to  (off), the Bypass mode is only available in the Manual ventilation mode (not available in the Auto ventilation mode). Start the manual ventilation, if you select the [Bypass] soft key in the manual mode and select [Yes] in the pop-up dialog box, the system will enter the Bypass mode.
 - When the [Bypass in Auto mode] is set to  (on), the Bypass mode is available in both the Manual and Auto ventilation modes. Start the ventilation, if you select the [Bypass] soft key on the Main Screen and select [Yes] in the pop-up dialog box, the system will enter the Bypass mode.

NOTE: When the Bypass mode is enabled, the [Alarms] button is disabled and automatically set to [Off].

When the system exits the Bypass mode, the [Alarms] button returns to its setting before the CPB mode is enabled.

6.7.4 High-flow Nasal Cannula Oxygen (HFNC)

High-flow Nasal Cannula Oxygen (HFNC) refers to a method to increase the O₂ concentration in the airway under atmospheric pressure through simple tubes. HFNC refers a medical measure that increases the alveolar O₂ concentration by increasing the O₂ concentration in the inhaled gas to promote O₂ diffusion, thereby increasing the partial pressure and saturation of blood oxygen in arteries so as to ease or rectify hypoxia. HFNC is a hypoxia prevention or treatment means and the O₂ concentration it provides is higher than that in the air.

CO₂ monitoring does not operate when HFNC is in use. Monitoring should be done by measuring the patient PaCO₂ values.

The working principle of HFNC is the same as the Auxiliary O₂/Air Flowmeter, however HFNC has a wider flow range (0 to 60L/min) than the Auxiliary O₂/Air Flowmeter (the flow range: 0 to 15L/min). The total flow of oxygen is up to 60 L/min. The total flow of air is up to 60 L/min. The total flow is up to 60 L/min.

WARNING: High Flow Nasal Cannula (HFNC) is indicated for delivery of nasal high flow oxygen to spontaneously breathing adult patients. It can be used for pre-oxygenation and short-term supplemental oxygenation (up to 10 minutes) during intubation in operating rooms. It is not intended for apneic ventilation. HFNC is indicated for use in adults only.

WARNING: HFNC can be applied to open or semi-open ventilations such as nasal cannula or mask ventilation, but it can not be applied to closed or semi-closed ventilations like tracheal intubation or laryngeal mask ventilation.

- WARNING:** Airway pressure and ventilation parameters related to respiration, such as flow rate, minute ventilation, apnea, are not monitored during HFNC.
- WARNING:** An SpO₂ monitoring device should be used to monitor SpO₂ during HFNC.
- WARNING:** Low gas supply pressure may cause inaccurate O₂ concentration control.
- WARNING:** Do not use antistatic or conductive breathing tubes. Using tubes made from such materials will expose the patient to electric shocks and may cause fires in an oxygen-enriched environment.
- WARNING:** The equipment must be used under the supervision of professional medical personnel. If a fault occurs to the equipment or the patient fails to perform enough spontaneous respiration, professional medical personnel can give immediate help.
- NOTE:** Stop the automatic ventilation before starting the HFNC. Otherwise it may cause inaccurate accuracy of the automatic ventilation or limited flow adjustment of HFNC.
- NOTE:** HFNC can be started only when the oxygen supply is connected.

To start the HFNC:

1. Connect the HFNC tube, See "High-flow Nasal Cannula Oxygen (HFNC) Tube" on Pages 3-10.
2. Press the HFNC switch to start the HFNC.
3. Adjust the oxygen concentration and total flow.
4. Press the HFNC switch to close the HFNC after use.

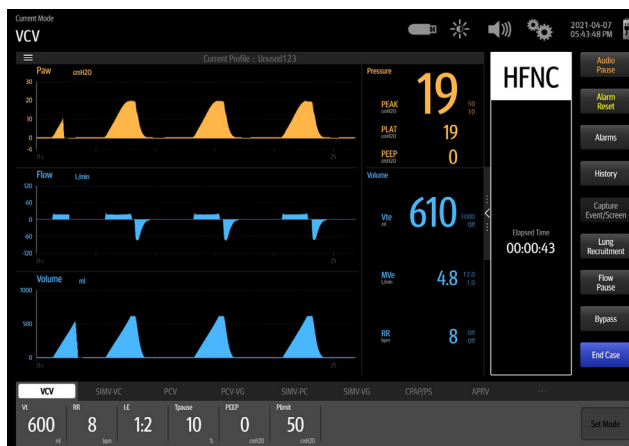

Figure 6-17 HFNC Screen

6.8 Start Automatic Ventilation

- NOTE:** Before starting a new automatic ventilation mode, ensure that all related ventilation parameters are set appropriately.
- NOTE:** Close the HFNC before starting the automatic ventilation to avoid affecting the accuracy of the automatic ventilation.

To start automatic ventilation from Standby mode:

1. Set the Auto/Manual switch to the Manual position.
2. Exit Standby by touching the Main Screen or by turning on the fresh gas.
3. Set the Auto/Manual Switch to the Auto position. The system will start automatic ventilation.

6.9 Stop Automatic Ventilation

To stop automatic ventilation:

1. Ensure that the breathing system is set up and the APL valve is set properly before stopping automatic ventilation.
2. Set the Auto/Manual switch to the Manual position. This selects manual ventilation and stops automatic ventilation.

6.10 Relationships of Ventilation Parameters

Different ventilation modes may share the same ventilation parameters and values. For example, SIMV-VC and VCV both include V_t , P_{limit} , RR, T_{pause} , and PEEP. Therefore, these parameter values that are linked may be passed from the previous ventilation mode to the current mode. "Ventilation Linkage Parameters" on Pages B-10 includes a table that lists how the linked parameter values are set when ventilation modes are changed.

Ventilation parameter values that are linked are set according to relationship equations. "Constraints Among Ventilation Parameters" on Pages B-14 includes a table of equations to show how linked parameter values are set when ventilation modes are changed.

This page intentionally left blank.

Anesthetic Gases and O₂ Concentration Monitoring

Introduction	7-2
MAC Values.....	7-3
Agent Usage Calculation	7-4
Agent Consumption Speed	7-4
Identify External AG Module.....	7-5
AG Measurement Preparation.....	7-6
AG Module Settings	7-7
Measurement Limits	7-9
Troubleshooting.....	7-10
Sample Gas Recirculation	7-10
Calibrate the AG Module	7-11

7.1 Introduction

The anesthetic gas (AG) module measures patients' anesthetic and respiratory gases and incorporates the functionalities of the O₂ module as well.

The AG (anesthesia gas) module determines the concentrations of certain gases using the infrared (IR) light absorption measurement. The gases that can be measured by the AG module absorb IR light. Each gas has its own absorption characteristic. The gas is transported into a sample cell, and an optical IR filter selects a specific band of IR light to pass through the gas. For multiple gas measurement, there are multiple IR filters. This means that higher concentration of IR absorbing gas causes a lower transmission of IR light. From the amount of IR light measured, the concentration of gas present can be calculated.

Oxygen does not absorb IR light as other breathing gases and is therefore measured relying on its paramagnetic properties. Inside the sensor of the O₂ module are two nitrogen-filled glass spheres hung on a torsion device in a symmetrical magnetic field. This assembly is suspended in a symmetrical non-uniform magnetic field. In the presence of paramagnetic oxygen, the glass spheres are pushed further away from the strongest part of the magnetic field. The strength of the torque acting on the suspension is proportional to the oxygen concentration. From the strength of the torque, the concentration of oxygen is calculated.

AG measurement provides:

1. Waveform: CO₂, N₂O, O₂ and AA waveforms.
2. Measured parameters: EtCO₂, FiCO₂, EtN₂O, FiN₂O, FiO₂, EtO₂, EtAA, FiAA and MAC.

Specifically, AA stands for any of the following anesthetic agents: Des (Desflurane), Iso (Isoflurane), Sev (Sevoflurane).

NOTE: If the AG module does not detect the N₂O, the monitoring value of N₂O will not be displayed on the Main Screen.

The rated respiration rate for the AG module is 2 to 100 bpm. The data sampling rate is 25 Hz. The peak value of the CO₂ waveform in the corresponding breathing cycle applies as the EtCO₂ gas reading. The peak value of the O₂ waveform in the corresponding breathing cycle applies as the O₂ gas reading. The EtN₂O and EtAA values at the time of the recorded CO₂ waveform apply as the EtN₂O and EtAA gas readings.

7.2 MAC Values

The minimum alveolar concentration (hereinafter referred to as MAC) can be displayed on the screen when the anesthesia system is configured with external AG module.

MAC is a basic index indicating the depth of inhaled anesthesia. The ISO 80601-2-55 defines MAC as follows: alveolar concentration of an inhaled anesthetic agent that, in the absence of other anesthetic agents and at equilibrium, prevents 50% of subjects from moving in response to a standard surgical stimulus.

The following table lists 1 MAC of various inhaled anesthetic agents.

anesthetic agent	Des	Iso	Enf	Sev	Hal	N ₂ O
1 MAC	6.0%	1.15%	1.70%	2.10%	0.77%	105%*

* 1 MAC of nitrous oxide can only be reached in a hyperbaric chamber.

Table 7-1 1 MAC of various inhaled anesthetic agents

NOTE: The data shown in this table are from ISO 80601-2-55, which are published by the U.S. Food and Drug Administration for a healthy 40-year-old male patient.

NOTE: In actual applications, although the gas module accounts for patient age, the effects of weight and other factors on the inhaled anesthetic agent should be considered.

When one or more anesthetic agents are used, the formula for calculating MAC is as follow:

$$MAC = \sum_{i=0}^{N-1} \frac{EtAgent_i}{AgentVol_{age}^i}$$

Where, N stands for the number of all anesthetic agents (including N₂O) which the AG module can measure, EtAgent_i stands for the end-tidal concentration of each kind of inhaled anesthetic agent, and AgentVol_{age}ⁱ stands for the 1 MAC value corresponding to each kind of inhaled anesthetic agent after age correction.

The formula for calculating age correction of 1MAC is as follow:

$$MAC_{age} = MAC_{40} \times 10^{(-0.00269 \times (age - 40))}$$

NOTE: The formula above is only available for patients who are older than one year old. If the patient is less than one year old, the system will use one year old to do age correction.

For example, for a 60-year-old patient, if the AG module detects 0.9% Iso and 50% N₂O in the patient end-tidal mixed gas, the 1MAC of Iso is 1.01% and 1MAC of N₂O is 92.7% of the 60-year-old patient based on the above age correction formula. The MAC value is calculated as follows::

$$MAC = \frac{0.9\%}{1.01\%} + \frac{50\%}{92.7\%} = 1.4$$

7.3 Agent Usage Calculation

CAUTION: The Agent Usage Calculation feature is intended for management purposes only and shall not be used as a basis for clinical decision-making.

The agent usage is displayed on the standby screen. The agent usage accumulates from 0 when the anesthesia system exits the standby mode. When the anesthesia system enters standby, the agent usage stops accumulating.

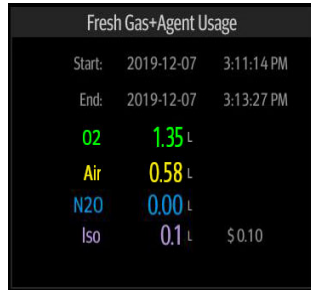







Figure 7-1 Agent Usage Calculation

Enable or disable the Agent Usage Calculation feature following the steps below:

1. Select the  soft key > [System] soft key (system password required) > [Setup] > [Optimizer] soft key.
2. Set the [Agent Usage] to  (off) or  (on). If the [Agent Usage] is set to  (off), no agent usage data is displayed on the Main Screen. If the [Agent Usage] is set to  (on), the agent usage is displayed on the Main Screen.

7.4 Agent Consumption Speed

CAUTION: The Agent Consumption Speed feature is intended for management purposes only and shall not be used as a basis for clinical decision-making.

The anesthesia system supports calculation of the agent consumption speed and cost.



Figure 7-2 Agent Consumption Speed

Enable or disable the Agent Consumption Speed feature following the steps below:

1. Select the  soft key > [System] soft key (system password required) > [Setup] > [Optimizer] soft key.

2. Set the [Agent Usage] to (off) or (on). If the [Agent Usage] is set to (off), no agent consumption speed is displayed on the Main Screen. If the [Agent Usage] is set to (on), the agent consumption speed is displayed on the Main Screen.
3. Set the Cost/ml of Liquid Agent. When the [Agent Usage] is set to (on), the cost of used agent is displayed on the Main Screen.

7.5 Identify External AG Module

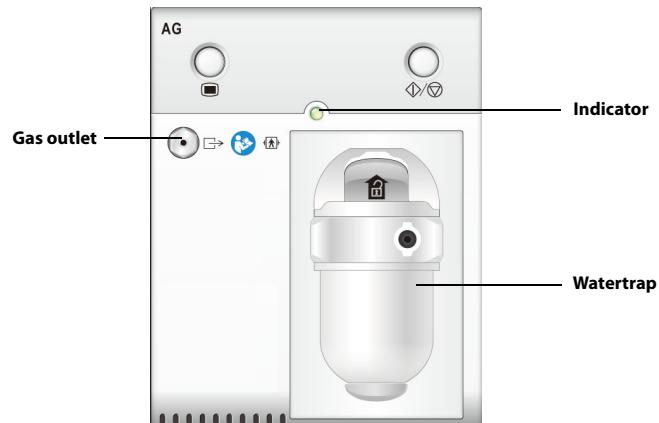

Figure 7-3 External AG module

- NOTE:** The AG module is configured with an automatic barometric pressure compensation feature.
- NOTE:** The buttons on the AG module have been disabled.
- NOTE:** The indicator will flash when the module performs a self-test or when the communication between the module and the system is abnormal. The indicator is on when the communication between the module and the system is normal.

7.6 AG Measurement Preparation

1. Select the appropriate watertrap according to patient type and attach it to the watertrap socket.
2. Connect one end of the gas sampling tube to the watertrap.
3. Connect the other end of the gas sampling tube to the patient via the airway adapter.
4. Connect the exhaust tube to the gas outlet on the module to channel the sample gas back to the patient circuit.

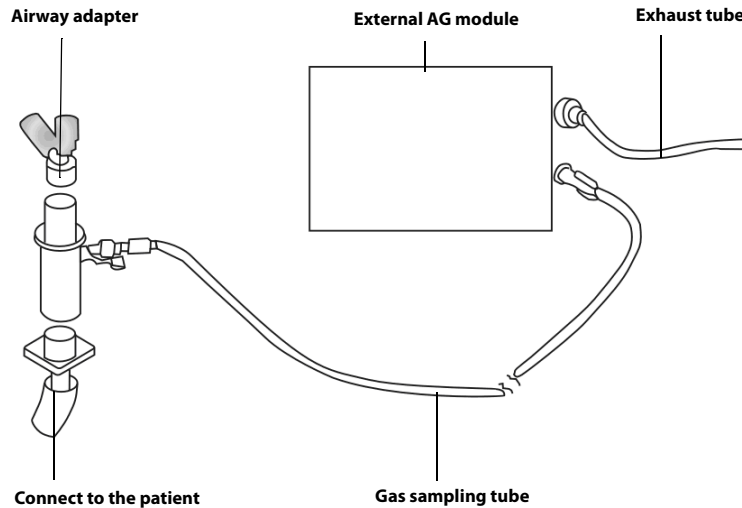

Figure 7-4 AG Measurement Preparation

- CAUTION:** Position the airway adapter properly so that the part connecting to the gas sampling tube is pointing upwards. This prevents condensed water from entering the gas sampling tube and causing an occlusion as a result.
- CAUTION:** The watertrap collects water drops condensed in the sampling tube and therefore prevents them from entering the module. If the collected water reaches a certain amount, you should drain it to avoid airway blockage.
- CAUTION:** The watertrap has a filter preventing bacterium, vapor and patient secretions from entering the module. After a long-term use, dust or other substances may compromise the performance of the filter or even block the airway. In this case, replace the watertrap. Replacing the watertrap once a month is recommended.
- WARNING:** Do not use the watertraps designed for adults/pediatric patients on infant patients. Otherwise it may cause injuries to the patients.
- WARNING:** Make sure that all connections are reliable. Any leak in the system can result in erroneous readings due to patient breathing gas mixed with ambient air.

7.7 AG Module Settings



You can do the following settings when the anesthesia system is configured with an external AG module.

7.7.1 Set Operating Mode

When the anesthesia system enters standby mode, then the AG module will also enter its standby mode. When the anesthesia system exits from standby mode, the AG module will also exit from its standby mode and enter measurement mode.



7.7.2 Set AG Flow Rate

To change the AG flow rate:

1. Select the  soft key > **[AG]** soft key.
2. Select the **[Flow Rate]** soft key.
3. Select an appropriate flow rate.
4. Select  to close the dialog box and confirm the changes.



7.7.3 Set CO₂ Unit

To change the CO₂ Unit:

1. Select the  soft key > **[System]** soft key (system password required) > **[Setup]** > **[Language/Unit]** key.
2. Select the **[CO₂ Unit]** key.
3. Choose between mmHg, kPa and %.
4. Select  to close the dialog box and confirm the changes.



7.7.4 Set CO₂ Scale

To change the CO₂ scale:

1. Select the  soft key > **[AG]** soft key.
2. Select the **[CO₂ Scale]** soft key.
3. Choose the appropriate scale.
4. Select  to close the dialog box and confirm the changes.

7.7.5 Set O₂ Scale

To change the O₂ scale:

1. Select the  soft key > **[AG]** soft key.
2. Select the **[O₂ Scale]** soft key.
3. Choose the appropriate scale.
4. Select  to close the dialog box and confirm the changes.

7.7.6 Set N₂O Scale



To change the N₂O scale:

1. Select the  soft key > **[AG]** soft key.

2. Select the **[N₂O Scale]** soft key.
3. Choose the appropriate scale.
4. Select  to close the dialog box and confirm the changes.

7.7.7 Set AA Scale

To change the AA scale:

1. Select the  soft key > **[AG]** soft key.
2. Select the **[AA Scale]** soft key. AA stands for any of the following anesthetic agents: Des (Desflurane), Iso (Isoflurane), Sev (Sevoflurane).
3. Choose the appropriate scale.
4. Select  to close the dialog box and confirm the changes.



7.7.8 Set Alarm Limits

Users can set the high and low alarm limits of N₂O, CO₂, O₂ and agents to keep alarm conditions consistent with patient needs. The alarm is then triggered when the parameter value is greater than the High Limit or lower than the Low Limit.

NOTE: When using the anesthesia system, ensure that the alarm limits of each parameter are set to the appropriate values for the patient.

1. On the Main Screen, select the **[Alarms]** soft key > **[Agents]** tab.
2. Select the soft key of the parameter you want to change.

NOTE: When the monitoring value on the Main Screen flashes due to an alarm, select the flashing area to open the corresponding Alarm Limits setting menu.

3. Enter the desired parameter value using the keyboard on the screen. For each parameter, the range of values is displayed above the keypad.
4. You can select the [**Load Alarm Defaults**] button to restore the default values. This restores the high and low limits of parameters to the user default values.
5. Select  to save the changes (or select  to discard the changes).

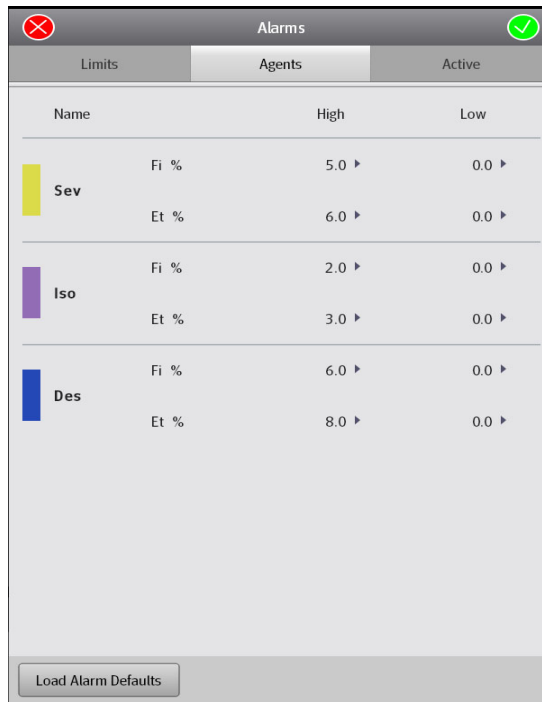

Alarms				
Limits		Agents		Active
Name		High	Low	
Sev	Fi %	5.0 ▸	0.0 ▸	
	Et %	6.0 ▸	0.0 ▸	
Iso	Fi %	2.0 ▸	0.0 ▸	
	Et %	3.0 ▸	0.0 ▸	
Des	Fi %	6.0 ▸	0.0 ▸	
	Et %	8.0 ▸	0.0 ▸	

Load Alarm Defaults

Figure 7-5 Agents tab

7.8 Measurement Limits

The following factors may reduce measurement accuracy:

- Leakage or internal sample gas leakage
- Mechanical shock
- Humidity or condensate
- Cyclic pressure greater than 10 kPa (100 cmH₂O)
- Other interference source (if present)

NOTE: The output gas data of the anesthesia module will be zero if the measured concentration is below the defined threshold for more than 3 seconds.

NOTE: Inaccuracy is specified at 10-55 °C operating temperature and default compensated for an H₂O partial pressure of 11 mBar (i.e. 22 °C @40% RH ambient conditions) and using a DRYLINE™ sampling system. Any other ambient H₂O partial pressure will dilute the gas sample to a different extent, causing a measurement error. Under typical operating conditions this effect is negligible. An increase of the ambient H₂O partial pressure to 30 mBar (i.e. 28 °C @80% RH or 33 °C @60% RH) will cause a general error for all measured gases of -2%_{REL}. For automatic compensation of the ambient humidity effect on the gas sample composition, the actual ambient H₂O partial pressure can be input to AION™ from the host via the communication interface.

7.9 Troubleshooting

If the gas inlet (including watertrap, sampling tube and airway adapter) is occluded by condensed water, airway occlusion will be prompted on the screen.

To remove the occlusion:

- Check the airway adapter for occlusion and replace it if necessary.
- Check the sampling tube for occlusion or kinking and replace it if necessary.
- Check the watertrap for water accumulation. Empty the watertrap. If the problem persists, replace the watertrap.

If the problem persists, internal occlusions may exist. Contact your service personnel.

If the exhaled O₂ concentration is higher than the inhaled O₂ concentration, it may be because of an overly low pump rate. It is recommended to set [Pump Rate] to [High].

7.10 Sample Gas Recirculation

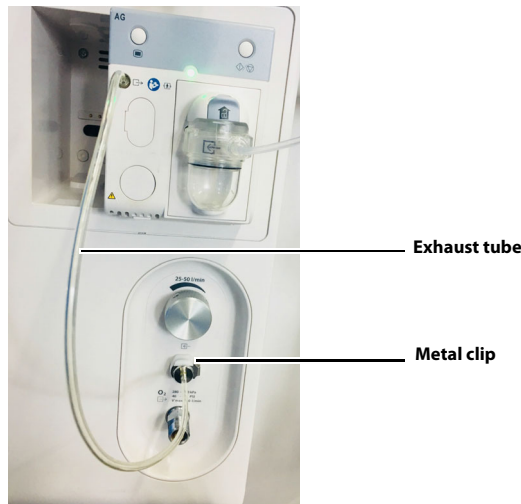



Figure 7-6 Sample gas recirculation

To return the sample gas to the patient circuit, plug the exhaust tube into the sample gas return port marked . A click indicates that the connector of the exhaust tube is installed in place, as shown above. Depress the metal clip to pull out the exhaust tube.

WARNING: When using AG module to perform AG measurements on the patient who is receiving or has recently received anesthetic agents, you must connect the gas outlet on the module to the sample gas return port to return the sample gas to the patient circuit, preventing the medical staff from breathing in the anesthetic agent.

WARNING: When the Sample Gas Recirculation feature is enabled, please install a breathing system filter compliant with the ISO 23328-1 and ISO 23328-2 standards on the patient end.

NOTE: The sample gas recirculation will not impact the measuring precision.

7.11 Calibrate the AG Module

Prepare the following before doing the calibration:

- Gas cylinder: contains a standard or mixed gas. The gas concentration should meet the following requirements: AA>1.5%, CO₂>1.5%, N₂O >40%, O₂>40%. AA represents an anesthetic gas.
- T-shape connector
- Breathing tubes

Follow this procedure to perform a calibration:

1. Use the T-shape connector to connect the gas cylinder, gas bag and sampling tube as follows.

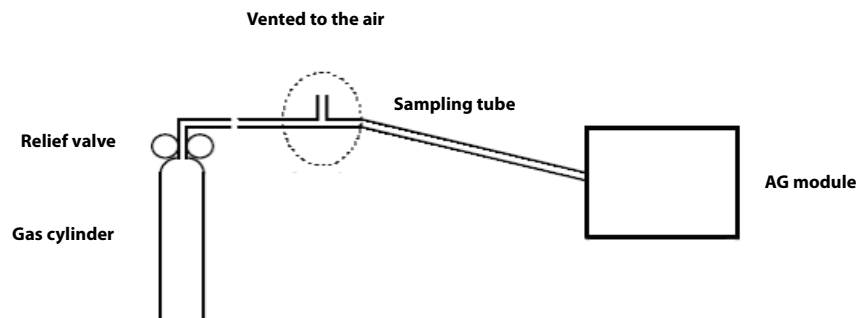



Figure 7-7 Calibrate the AG module

2. Ensure that the system is in Standby mode. Otherwise, select the **[End Case]** soft key on the Main Screen and follow the on-screen prompts to enter the standby mode.
3. Select the  soft key > **[System]** soft key (system password required).
4. Select the **[Calibrate]** soft key.
5. Select the **[AG Module]** or **[Internal AG Module]** soft key.
6. Wait for the AG module to be fully warmed up.
7. Enter the actual concentration of the calibration gas.
8. Turn on the calibration gas canister. The system displays the real-time concentration of calibration gas.
9. Select the **[Begin]** soft key to start calibrating the AG module. The system will display the results of the calibration status when the process is completed.
10. Select the **[Done]** soft key after the calibration is successful. If the calibration failed, select the **[Retry]** soft key to calibrate the module again.
11. Select  to close the window.

Alarms and Messages

Introduction	8-2
Alarm Display	8-4
Setting Alarm Volume.....	8-6
Pause Alarm Audio.....	8-7
Setting Alarm Limits.....	8-8
View Active Alarms	8-11
Alarms and Prompt Messages.....	8-12

8.1 Introduction

The system provides alarms and messages that are indicated to the user by visual and audible alerts. Alarms and messages display at the top of the Main Screen and in the Alarms window (See Figure 8-1). Users can adjust alarm properties, which include setting alarm limits to trigger alarm conditions, adjusting alarm volume, and pausing alarm audio(See Figure 8-1).



Figure 8-1 Alarms and messages on the Main Screen

8.1.1 Alarm System Self-Test

The system performs a self-test of its alarm system when powered on. The self-test is described as follows:

- During the self-test, the alarm LED will illuminate in sequence with the colors red, yellow, and cyan for approximately 1 second each color.
- The system speaker produces one tone after the alarm light is in self-test.

8.1.2 Types of Alarms and Messages

The equipment provides the following types of alarms and prompt messages. See (Pages 8-12) 8.8 "Alarms and Prompt Messages" for a list of alarms and prompt messages.

- **Physiological Alarm:**
Patient-related variables cause physiological alarms. These alarms require a user response. Physiological alarms can have the following priorities: high, medium, and low.
- **Technical Alarm:**
Machine-related variables cause technical alarms. These alarms require a user response. Technical alarms can have the following priorities: high, medium and low.
- **Prompt Message:**
This is a message to the user. They do not require an immediate user response. These messages always have the lowest priority, below physiological and technical alarms. It is displayed in white.

8.1.3 Alarm Indicators

The equipment provides the following alarm indicators:

- **Alarm LED located on the top of LCD monitor.** The LED can illuminate in red, yellow, cyan, or OFF, depending on the alarm condition.

Table 8-1 describes the alarm behavior of various alarm types and various alarm priority levels. If multiple alarms occur simultaneously, the audio and LED behavior will follow the active alarm with the highest priority.

- **Colored alarm messages displayed on the Main Screen.** High priority messages are red. Medium priority messages are yellow. Low priority messages are cyan. Prompt messages are white. Messages display according to priority and time. (See "Display Rules of Alarm Messages" on Pages 8-5.)
- **Alarm audio from the system alarm speaker.** Table 8-1 lists the audio behavior for each alarm type.









ALARM TYPE	ALARM PRIORITY	AUDIO BEHAVIOR	MESSAGE BEHAVIOR	ALARM LED COLOR
Physiological Alarm	High	Play high priority alarm sounds at an interval of 5 ± 1 seconds.	White text on red background, high priority icon. 	Red
	Medium	Play medium priority alarm sounds at an interval of 5 ± 1 seconds.	Black text on yellow background, medium priority icon. 	Yellow
	Low	Play low priority alarm sounds at an interval of 17 ± 1 seconds.	White text on cyan background, low priority icon. 	Cyan
Technical Alarm	High	Play high priority alarm sounds at an interval of 5 ± 1 seconds.	White text on red background, high priority icon. 	Red
	Medium	Play medium priority alarm sounds at an interval of 5 ± 1 seconds.	Black text on yellow background, medium priority icon. 	Yellow
	Low	Play low priority alarm sounds at an interval of 17 ± 1 seconds.	White text on cyan background, low priority icon. 	Cyan
Prompt Message	None	None	Black text on white background	Off

Table 8-1 Alarm indicators (audio and on-screen messages)

8.2 Alarm Display

On the LCD monitor screen, alarm messages are automatically displayed on the top of the Main Screen when alarm conditions are met (see Figure 8-1). Additionally, a list of all active alarms can be found in the Alarms window (see Figure 8-2).

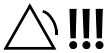
Each message is displayed with an associated priority symbol as follows:

- High priority 
- Medium priority 
- Low priority 

To display a list of all active alarms:

1. On the Main Screen, select the **[Alarms]** soft key or touch the Alarm Message area on the top of the screen.
The Alarms window displays.
2. Select the **[Active]** tab.
A list of all active alarm messages is displayed (Figure 8-2).
Alarms are displayed in order of priority and time.

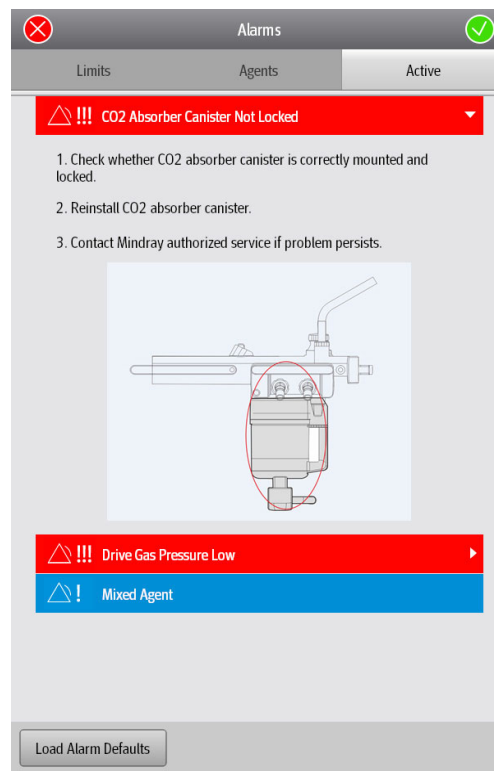

Figure 8-2 Active Alarms list in the Alarms window

8.2.1 Display Rules of Alarm Messages

Alarm messages are displayed in order of priority and time of occurrence.

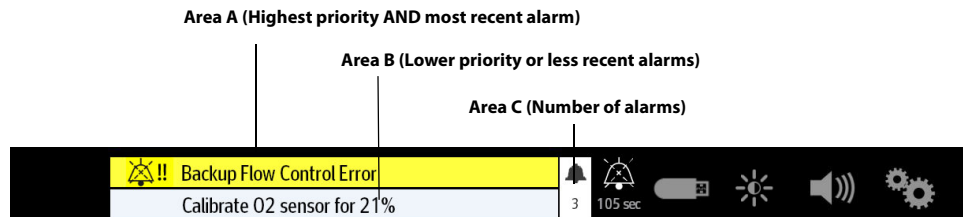

Figure 8-3 Display Rules of Alarm Messages

Alarm messages are displayed in Area A, Area B and Area C, according to the following rules:

- To be in Area A, an alarm must be both the highest priority AND the most recent (Area A does not cycle). The remaining active alarms and prompt messages cycle in Area B.
- New Alarms with lower priority than alarms in Area A are displayed directly in Area B, and the cycle proceeds from that position in the list.
- Alarms cycling in Area B are grouped and displayed in the following order: high, medium, low, and prompt messages. In each group, the most recent alarm displays first.
- If the alarm in Area A is removed, then the most recent alarm with the highest priority from Area B is moved to Area A.
- Area C displays the number of active alarms.

8.3 Setting Alarm Volume

The Alarms Volume settings adjust the audio level of all high, medium, and low priority sounding alarms. The System Alert Volume settings adjust the audio level of all sounding pop-up prompts and non-confirmed ventilation mode alerts.

To set the Alarm Volume:

1. On the Main Screen, select the  soft key.
2. Adjust the volume on the pop-up screen.

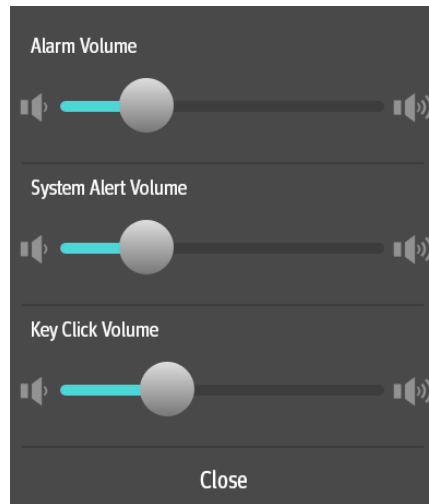

Figure 8-4 Setting Alarm Volume

WARNING: Do not rely exclusively on the audible alarm system when using the anesthesia system. Adjustment of alarm volume to a low level may result in a hazard to the patient. Always keep the patient under close surveillance.

NOTE: The auditory alarm signal A-weighted sound pressure level shall be no less than 45dB and no more than 85dB.

8.4 Pause Alarm Audio

Clicking the **[Audio Pause]** soft key will pause the alarm audio for 120 seconds, no matter whether the anesthesia system has active alarms. All the other alarming indicators work normally except the alarm audio. The alarm audio pause icon and 120 seconds countdown are displayed on the top of the screen. When **[Audio Pause]** is enabled, the audio of new alarms is also paused. After the 120 seconds countdown, the system will exit from the audio pause state. When **[Audio Pause]** is enabled, click the **[Audio Pause]** soft key again to exit from the audio pause state.

Audio Pause Icon and 120-seconds Countdown Timer



Figure 8-5 Alarm Audio Pause icon

8.5 Alarm Reset

When an alarm condition occurs and triggers an audio alarm, select the **[Alarm Reset]** soft key to pause the audio of all active alarms. If the reset alarms contain medium or high priority alarms, the alarm audio will be paused for 120 seconds. The Alarm Reset icon and the 120-seconds countdown timer are displayed on the top of the screen. Select the soft key again to resume the alarm audio. When the alarms are reset, all the alarming indicators work normally except the alarm audio.

NOTE: If a new alarm occurs, the new alarm will sound even when the system is in an Alarm Reset status. In this case, you can select the **[Alarm Reset]** soft key again to pause the new alarm audio and reset the countdown to 120 seconds.

Alarm Reset Icon and 120-seconds Countdown Timer



Figure 8-6 Alarm Reset icon

If the reset alarms contain only low priority alarms, the alarm audio will be turned off. If a new alarm occurs, the new alarm will sound.

NOTE: If a new alarm occurs, the new alarm will sound if the new alarm is a low priority one even when the alarm audio is turned off. In this case, you can select the **[Alarm Reset]** soft key again to turn off the alarm audio. If the new alarms occurred contain medium or high level alarms, then the new alarm audio will sound. In this case, you can select the **[Alarm Reset]** soft key again to pause the new alarm audio and start a 120-seconds countdown.

Alarm Audio Off icon



Figure 8-7 Alarm Audio Off icon

8.6 Setting Alarm Limits

Users can set the limits of PEAK, MV, Vte, RR, FiO₂, EtO₂, FiN₂O, EtN₂O, EtCO₂ and FiCO₂ alarms to align the alarm conditions consistent with patient needs. The alarm is then triggered when the parameter value is greater than the High Limit or lower than the Low Limit.

WARNING: During equipment use, pay frequent attention to the alarm limits of parameters to ensure that they are appropriately set. Setting the alarm limits to limiting values will render the alarming system unhelpful.

NOTE: When using the anesthesia system, ensure that the alarm limits of each parameter are set to the appropriate values for the patient.

NOTE: When the anesthesia system restarts within 60 seconds after a power outage, the system can automatically restore the recent profile. If the power outage lasts longer than 120 seconds, the anesthesia system will automatically load the user profile before the shutdown. If the power outage lasts between 60 to 120 seconds, the anesthesia system may automatically restore the recent profile or automatically load the user profile before the shutdown.

NOTE: If the equipment is powered off for less than 30 seconds and then powered on, the alarming settings will be restored to the status before the system was powered off.

NOTE: If the airway pressure monitoring stays lower than the lower limit of alarm for 20 seconds or one automatic ventilation cycle (depending on which one is longer), a corresponding alarm will be triggered.

NOTE: If the Vte monitoring stays higher than the upper limit of alarm for three consecutive cycles, a corresponding alarm will be triggered.

NOTE: If the Vte monitoring stays lower than the lower limit of alarm for three consecutive cycles, a corresponding alarm will be triggered.

NOTE: In the manual ventilation mode, the system will disable the [Paw Too Low] alarm, and the PEAK low alarm limit in monitoring parameters area will display [Off].

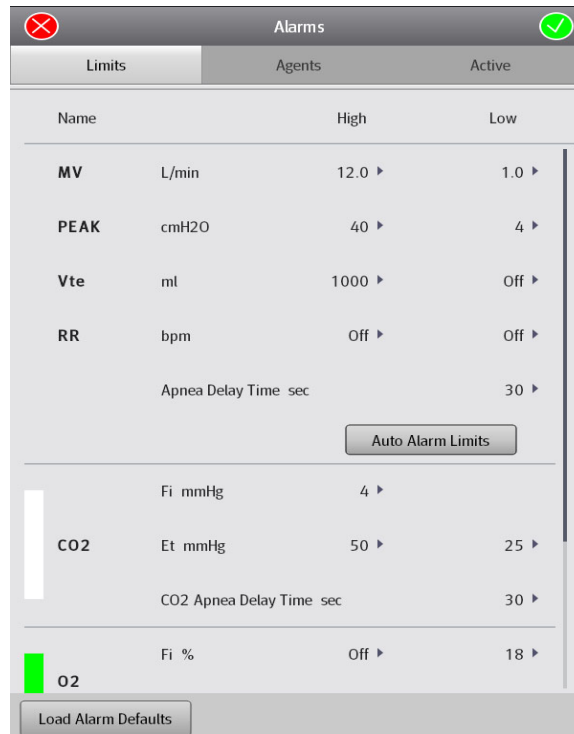





Figure 8-8 Limits Tab

To set alarm limits:

1. On the Main Screen, select the **[Alarms]** soft key > **[Limits]** tab.
2. Select a parameter soft key.

NOTE: When the monitoring value on the Main Screen flashes due to an alarm, select the flashing area to open the corresponding Alarm Limits setting menu.

3. Enter the desired parameter value using the keyboard on the screen. For each parameter, the range of values is displayed above the keypad.
4. You can select **[Load Alarm Defaults]** to restore the default values and restore the upper and lower limits of parameter alarms to the factory defaults.
5. Repeat Steps 3 and 4 for each parameter.
6. Select  to save the changes (or select  to discard the changes).
7. To save an alarm limit to a user profile:
 - Select the  soft key > **[System]** soft key (system password required) > **[Profiles]** tab. Select a profile, and select the **[Create]** soft key. Set the profile name on the pop-up screen. After the profile is confirmed, the system will save the current profile as a user profile.
8. To load a user profile:
 - In the standby mode, select the **[Current Profile: xxxx]** soft key and select the desired profile on the pop-up screen.
 - Select the **[Manual]** ventilation mode, and select the **[Load Profile]** soft key on the pop-up screen, and then select the desired profile on the pop-up screen.

8.6.1 Auto Alarm Limits

The Auto Alarm Limits function uses an algorithm based on measured values. The relationship is shown in the table below.

When the System is in Standby mode or Manual mode, the **[Auto Alarm Limits]** button will be disabled. The **[Auto Alarm Limits]** key is also disabled when the current mode is PS, SIMV-VC, or SIMV-PC.

ALARM LIMIT	ADJUSTMENT FORMULA
PEAK High	PEAK+5 or PLAT+10, whichever is greater. Minimum: 35 cmH ₂ O.
PEAK Low	(PLAT-PEEP) x 0.6 + PEEP - 1 Minimum: 3 cmH ₂ O. Maximum (PEAK High - 1)
MV High	MV x 1.4 Minimum: 2.0 L/min
MV Low	MV x 0.6 Minimum: 0.1 L/min Maximum (MV High - 0.1)
Vte High	Vte x 1.4
Vte Low	Vte x 0.6
RR High	RR x 1.4
RR Low	RR x 0.6

Table 8-2 Auto Alarm Limits

The parameters in the formula are all measured parameters.

The alarm limits for PEAK are calculated on the basis of the average value for PEAK, PLAT, and PEEP. The value used for average uses the value of the last four ventilation cycles or the value in one minute, whichever is smaller. Spontaneous breaths by the patient are not taken into account.

The alarm limits for Vt and RR are calculated on the basis of the average value. The value used for average uses the value of the last four ventilation cycles or the value in one minute, whichever is smaller. Spontaneous breaths by the patient are not taken into account.

If there is no valid MV, Vte or RR measurement value, the corresponding alarm limits will not be adjusted.

If the average value of PEAK, PLAT, and PEEP cannot be calculated, the corresponding alarm limits will not adjust.

If the calculated alarm limit is more than the high threshold of setting range or less than the low threshold, the corresponding threshold is used as the auto alarm limit.

8.7 View Active Alarms

To display a list of all active alarms:

On the Main Screen, select the **[Alarms]** soft key or touch the Alarm Message area on the top of the screen. The Alarms window displays.

1. Select the **[Active]** tab.
A list of all active alarm messages is displayed (Figure 8-9).

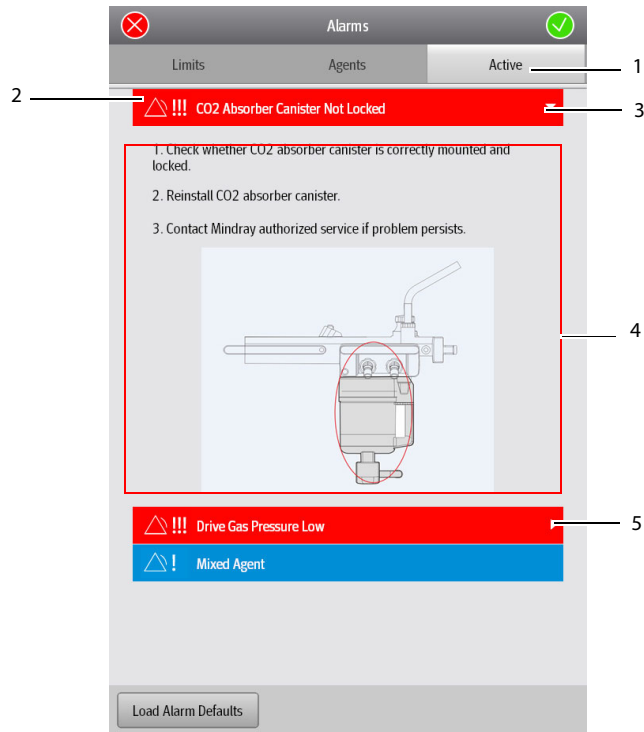

Figure 8-9 Active Alarms list in the Alarms window

2. Alarm Messages
 - Red: indicates high priority alarm.
 - Yellow: indicates medium priority alarm.
 - Cyan: indicates low priority alarm.
 - White: indicates prompt message.
3. Help information soft key
Select the soft key to display the help information in the expanded window. Select the softkey again to close the Help information window. Only the alarms with high priority have help information.
4. Help information
5. Scroll bar
Scroll the bar to view more alarm information.

8.8 Alarms and Prompt Messages

This section lists the following alarms and messages:

- Physiological Alarm Messages
- Technical Alarm Messages
- Prompt Message

For each alarm message, the system has provided corresponding troubleshooting measures. If the problem persists, contact your service personnel.

NOTE: The [Disable in Cardiac Bypass Mode] column indicates whether the physiological alarm is blocked in the Cardiac Bypass mode.

NOTE: The [Disable in Standby Mode] column indicates whether the physiological alarm is blocked in the standby mode.

NOTE: You can view past alarms in the [History] menu.

8.8.1 Physiological Alarm Messages

INFORMATION	CAUSE	ACTION	ALARM PRIORITY	DISABLE WHEN ALARM IS OFF	DISABLE IN CARDIAC BYPASS MODE	DISABLE IN STANDBY MODE	DISABLE IN MONITOR MODE	DISABLE IN ACGO MODE
Apnea	No breath has been detected within the apnea time.	1. Check alarm limit: Tapnea. 2. Check whether patient circuit is leaking or disconnected. 3. Ensure the position of Auto/manual switch is correct.	Medium	Yes	Yes	N/A *	Yes	Yes
Apnea > 2 minutes	No breath has been detected within the last 120 seconds.	1. Check whether ventilation starts. 2. Check whether patient circuit is leaking or disconnected. 3. Ensure the position of Auto/manual switch is correct.	High	Yes	Yes	N/A *	Yes	Yes
Paw Too High	Paw > high alarm limit setting.	1. Check alarm limit: PEAK High. 2. Check ventilation settings: P _{insp} /ΔP _{insp} , V _t , PEEP, etc. 3. Check whether patient circuit is kinked or blocked.	High	No	No	N/A *	Yes	No

Table 8-3 Physiological Alarm Messages

INFORMATION	CAUSE	ACTION	ALARM PRIORITY	DISABLE WHEN ALARM IS OFF	DISABLE IN CARDIAC BYPASS MODE	DISABLE IN STANDBY MODE	DISABLE IN MONITOR MODE	DISABLE IN ACGO MODE
Paw Too Low	Paw < low alarm limit setting for 20 seconds.	1. Check alarm limit: PEAK Low. 2. Check ventilation settings: P _{insp} /ΔP _{insp} , V _t , PEEP, etc. 3. Check whether patient circuit is leaking or disconnected.	High	Yes	Yes	N/A *	Yes	Yes
Pressure Limit	Paw ≥ P _{limit} .	Check ventilation settings: P _{limit} .	Low	N/A *	N/A *	N/A *	N/A *	Yes
FiO₂ Too High	FiO ₂ > high alarm limit setting.	1. Check alarm limit: FiO ₂ High. 2. Check fresh gas O ₂ setting. 3. Check fresh gas balance gas setting, and the balance gas source is connected correctly.	Medium	No	No	N/A *	No	Yes
FiO₂ Too Low	FiO ₂ < low alarm limit setting.	1. Check alarm limit: FiO ₂ Low. 2. Check fresh gas O ₂ setting. 3. Check whether patient circuit is leaking.	High	No	No	N/A *	No	Yes
MV Too High	MV > high alarm limit setting.	1. Check alarm limit: MV High. 2. Check ventilation settings: P _{insp} /ΔP _{insp} , V _t , RR, etc.	Medium	Yes	Yes	N/A *	Yes	Yes
MV Too Low	MV < low alarm limit setting.	1. Check alarm limit: MV Low. 2. Check ventilation settings: P _{insp} /ΔP _{insp} , V _t , RR, etc. 3. Check whether patient circuit is leaking or blocked.	Medium	Yes	Yes	N/A *	Yes	Yes
Vte Too High	Vte > high alarm limit setting.	1. Check alarm limit: Vte High. 2. Check ventilation settings: P _{insp} /ΔP _{insp} , V _t , etc.	Medium	Yes	Yes	N/A *	Yes	Yes
Vte Too Low	Vte < low alarm limit setting.	1. Check alarm limit: Vte Low. 2. Check ventilation settings: P _{insp} /ΔP _{insp} , V _t , etc. 3. Check whether patient circuit is leaking or blocked.	Medium	Yes	Yes	N/A *	Yes	Yes

Table 8-3 Physiological Alarm Messages

INFORMATION	CAUSE	ACTION	ALARM PRIORITY	DISABLE WHEN ALARM IS OFF	DISABLE IN CARDIAC BYPASS MODE	DISABLE IN STANDBY MODE	DISABLE IN MONITOR MODE	DISABLE IN ACGO MODE
RR Too High	RR > high alarm limit setting.	1. Check alarm limit: RR High. 2. Check ventilation settings: RR, F-Trig/P-Trig, etc. 3. Check whether patient circuit is leaking or blocked.	Low	Yes	Yes	N/A *	Yes	Yes
RR Too Low	RR < low alarm limit setting.	1. Check alarm limit: RR Low. 2. Check ventilation settings: RR, F-Trig, etc.	Low	Yes	Yes	N/A *	Yes	Yes
Continuous Airway Pressure Too High	Paw in the breathing circuit > continuous airway pressure alarm limit for 15 seconds. In ACGO mode, the continuous airway pressure alarm is disabled.	1. Check APL valve setting while in manual mode. 2. Check whether patient circuit or AGSS is blocked.	High	No	No	N/A *	Yes	No
Negative Pressure in Airway	Paw < -10 cmH ₂ O for 1 second.	1. Check whether the volume exchanger display stops motion. 2. Check the negative pressure suction. 3. Check whether AGSS works normally.	High	No	No	N/A *	Yes	No
EtCO₂ Too High	EtCO ₂ > high alarm limit setting.	1. Check alarm limit: EtCO ₂ High 2. Check whether need to replace Soda Lime in the CO ₂ absorber canister.	Medium	No	Yes	Yes	No	No
EtCO₂ Too Low	EtCO ₂ < low alarm limit setting.	1. Check alarm limit: EtCO ₂ Low. 2. Check whether the sampleline is disconnected.	Medium	No	Yes	Yes	No	No
FiCO₂ Too High	FiCO ₂ > high alarm limit setting.	1. Check alarm limit: FiCO ₂ High. 2. Check whether need to replace Soda Lime in the CO ₂ absorber canister.	Medium	No	Yes	Yes	No	No

Table 8-3 Physiological Alarm Messages

INFORMATION	CAUSE	ACTION	ALARM PRIORITY	DISABLE WHEN ALARM IS OFF	DISABLE IN CARDIAC BYPASS MODE	DISABLE IN STANDBY MODE	DISABLE IN MONITOR MODE	DISABLE IN ACGO MODE
EtN₂O Too High	EtN ₂ O > high alarm limit.	1. Check alarm limit: EtN ₂ O High. 2. Check fresh gas balance gas setting.	Medium	No	No	Yes	No	No
EtN₂O Too Low	EtN ₂ O < low alarm limit.	1. Check alarm limit: EtN ₂ O Low. 2. Check whether the sampleline is disconnected. 3. Check fresh gas N ₂ O setting, and the N ₂ O source is connected correctly.	Medium	No	Yes	Yes	No	No
FiN₂O Too High	FiN ₂ O > high alarm limit.	1. Check alarm limit: FiN ₂ O High. 2. Check fresh gas balance gas setting.	Medium	No	No	Yes	No	No
FiN₂O Too Low	FiN ₂ O < low alarm limit.	1. Check alarm limit: FiN ₂ O Low. 2. Check whether the sampleline is disconnected. 3. Check fresh gas N ₂ O setting, and the N ₂ O source is connected correctly.	Medium	No	Yes	Yes	No	No
EtISO Too High	EtISO > high alarm limit setting.	1. Check alarm limit: EtIso High. 2. Check AA% setting.	Medium	No	No	Yes	No	No
EtISO Too Low	EtISO < low alarm limit setting.	1. Check alarm limit: EtIso Low. 2. Check AA% setting. 3. Check whether the sampleline is disconnected.	Medium	No	Yes	Yes	No	No
FiISO Too High	FiISO > high alarm limit setting.	1. Check alarm limit: FiISO High. 2. Check AA% setting.	Medium	No	No	Yes	No	No
FiISO Too Low	FiISO < low alarm limit setting.	1. Check alarm limit: FiIso Low. 2. Check AA% setting. 3. Check whether the sampleline is disconnected.	Medium	No	Yes	Yes	No	No
EtSEV Too High	EtSEV > high alarm limit setting.	1. Check alarm limit: EtSev High. 2. Check AA% setting.	Medium	No	No	Yes	No	No

Table 8-3 Physiological Alarm Messages

INFORMATION	CAUSE	ACTION	ALARM PRIORITY	DISABLE WHEN ALARM IS OFF	DISABLE IN CARDIAC BYPASS MODE	DISABLE IN STANDBY MODE	DISABLE IN MONITOR MODE	DISABLE IN ACGO MODE
EtSEV Too Low	EtSEV < low alarm limit setting.	1. Check alarm limit: EtSev Low. 2. Check AA% setting. 3. Check whether the sampleline is disconnected.	Medium	No	Yes	Yes	No	No
FiSEV Too High	FiSEV > high alarm limit setting.	1. Check alarm limit: FiSev High. 2. Check AA% setting.	Medium	No	No	Yes	No	No
FiSEV Too Low	FiSEV < low alarm limit setting.	1. Check alarm limit: FiSev Low. 2. Check AA% setting. 3. Check whether the sampleline is disconnected.	Medium	No	Yes	Yes	No	No
EtDES Too High	EtDES > high alarm limit setting.	1. Check alarm limit: EtDes High. 2. Check AA% setting.	Medium	No	No	Yes	No	No
EtDES Too Low	EtDES < low alarm limit setting.	1. Check alarm limit: EtDes Low. 2. Check AA% setting. 3. Check whether the sampleline is disconnected.	Medium	No	Yes	Yes	No	No
FiDES Too High	FiDES > high alarm limit setting.	1. Check alarm limit: FiDes High. 2. Check AA% setting.	Medium	No	No	Yes	No	No
FiDES Too Low	FiDES < low alarm limit setting.	1. Check alarm limit: FiDes Low. 2. Check AA% setting. 3. Check whether the sampleline is disconnected.	Medium	No	Yes	Yes	No	No
EtO₂ Too High	EtO ₂ > high alarm limit setting.	1. Check alarm limit: EtO ₂ High. 2. Check fresh gas O ₂ setting. 3. Check fresh gas balance gas setting, and the balance gas source is connected correctly.	Medium	No	No	Yes	No	No
EtO₂ Too Low	EtO ₂ < low alarm limit setting.	1. Check alarm limit: EtO ₂ Low. 2. Check fresh gas O ₂ setting. 3. Check whether patient circuit is leaking.	Medium	No	No	Yes	No	No

Table 8-3 Physiological Alarm Messages

INFORMATION	CAUSE	ACTION	ALARM PRIORITY	DISABLE WHEN ALARM IS OFF	DISABLE IN CARDIAC BYPASS MODE	DISABLE IN STANDBY MODE	DISABLE IN MONITOR MODE	DISABLE IN ACGO MODE
FiO₂ Too High	FiO ₂ > high alarm limit setting.	1. Check alarm limit: FiO ₂ High. 2. Check fresh gas O ₂ setting. 3. Check fresh gas balance gas setting, and the balance gas source is connected correctly.	Medium	No	No	Yes	No	No
FiO₂ Too Low	FiO ₂ < low alarm limit setting.	1. Check alarm limit: FiO ₂ Low. 2. Check fresh gas O ₂ setting. 3. Check whether patient circuit is leaking.	High	No	No	Yes	No	No
Apnea CO₂	No breath is detected and Apnea time ≥ Apnea alarm time.	1. Check whether ventilation starts. 2. Ensure the sampleline is correctly connected to patient circuit. 3. Check patient's breathing ability.	High	No	Yes	Yes	No	No

* Not applicable. The alarm message does not exist within this mode and therefore it cannot be disabled or enabled.

Table 8-3 Physiological Alarm Messages

8.8.2 Technical Alarm Messages

8.8.2.1 Startup Alarm Messages

NOTE: Startup alarms will not trigger the alarm audio and alarm light.

NOTE: The priority of startup alarms is only displayed in the alarm log.

NOTE: Startup Result if Fail column indicates the result when the startup phase alarm is triggered, which may be All, Only Manual, and Non-Functional.

NOTE: [All] indicates that all Automatic Ventilation, Manual Ventilation, and Cardiac Bypass modes are enabled.

[Only Manual] indicates that only Manual Ventilation and Cardiac Bypass modes are enabled.

[Non-Functional] indicates that the anesthesia system cannot be used.

INFORMATION	CAUSE	ACTION	ALARM PRIORITY	MACHINE MODE WHEN CHECKED	STARTUP RESULT IF FAIL
Bundle Version Error	Incompatible firmware version is installed.	Please contact Mindray Technical Support.	High	Startup	Non-Functional
Bundle Version: Timeout	Self-test result cannot be obtained due to an internal communication error.		High	Startup	Non-Functional
Flowmeter Self Test Error	1. Board self-test error. 2. Valve self-test error. 3. Branch leakage, etc.	1. Repeat the test. 2. Please contact Mindray Technical Support if the problem persists.	High	Startup	Non-Functional
Flowmeter Self Test: Time out	Self-test result cannot be obtained due to an internal communication error.		High	Startup	Non-Functional
BFCS self-test error	BFCS self-test error	1. Restart machine to repeat the test. 2. Please contact Mindray Technical Support if the problem persists.	High	Startup	All
Aux Control Module Selftest Error	1. Board self-test error. 2. After being powered on, the CPU board failed to communicate with the auxiliary monitoring board.	1. Repeat the test. 2. Please contact Mindray Technical Support if the problem persists.	High	Startup	Non-Functional
Auxi Ctrl Module Self Test: Time out	Self-test result cannot be obtained due to an internal communication error.		High	Startup	Non-Functional
Ventilator Selftest Error	1. Board self-test error. 2. After being powered on, the CPU board failed to communicate with the ventilator.	1. Repeat the test. 2. Please contact Mindray Technical Support if the problem persists.	High	Startup	Non-Functional
Ventilator Control Board Self Test: Time out	Self-test result cannot be obtained due to an internal communication error.		High	Startup	Non-Functional
Ventilator Voltage Error	Ventilator voltage error.		High	Startup	Manual Only
PEEP Valve Failure	1. PEEP valve voltage error. 2. PEEP valve pressure error.	1. Repeat the test. 2. Please contact Mindray Technical Support if the problem persists.	Medium	Startup	Manual Only
Insp Valve Failure	1. Inspiratory valve voltage error. 2. Inspiratory valve flow error.	1. Repeat the test. 2. Please contact Mindray Technical Support if the problem persists.	Medium	Startup	Manual Only

Table 8-4 Startup Alarm Messages

INFORMATION	CAUSE	ACTION	ALARM PRIORITY	MACHINE MODE WHEN CHECKED	STARTUP RESULT IF FAIL
Safety Valve Failure	Safety valve voltage error.	1. Repeat the test. 2. Please contact Mindray Technical Support if the problem persists.	Medium	Startup	Manual Only
Vaporizer self-test error	Vaporizer self-test error	1. Repeat the test. 2. Please contact Mindray Technical Support if the problem persists.	High	Startup	All
Vaporizer Self Test: Time out	Self-test result cannot be obtained due to an internal communication error.	1. Repeat the test. 2. Please contact Mindray Technical Support if the problem persists.	High	Startup	All
Vaporizer Dock Failure	1. Bypass fault. 2. Fresh gas inlet or outlet valve fault.	1. Repeat the test. 2. Please contact Mindray Technical Support if the problem persists.	High	Startup	Non-Functional
Auto/Manual Switching Failure	Auto/Manual position switch failure	1. Repeat the test. 2. Please contact Mindray Technical Support if the problem persists.	High	Startup	Manual Only
	Auto/manual valve fault	Mindray Technical Support if the problem persists.	High	Startup	Non-Functional
Flow Sensor Failure	Ventilator flow is out of range.	1. Repeat the test. 2. Please contact Mindray Technical Support if the problem persists.	Low	Startup	Manual Only
Calibrate Flow Sensor and Insp Valve	1. Calibration table isn't found in EEPROM. 2. Checksum of the calibration table does not match.	1. Calibrate flow sensors through Service menu after entering Standby. 2. Please contact Mindray Technical Support if the problem persists.	Low	Startup	Manual Only
Calibrate Pressure Sensor and PEEP Valve	1. Calibration table isn't found in EEPROM. 2. Checksum of the calibration table does not match.	Please contact Mindray Technical Support for pressure calibration.	Low	Startup	Manual Only
Calibrate 21% and 100% O₂ Sensor	1. Calibration table isn't found in EEPROM. 2. Checksum of the calibration table does not match.	1. Calibrate O ₂ sensors through System menu after entering Standby. 2. Please contact Mindray Technical Support if the problem persists.	Low	Startup	All

Table 8-4 Startup Alarm Messages

INFORMATION	CAUSE	ACTION	ALARM PRIORITY	MACHINE MODE WHEN CHECKED	STARTUP RESULT IF FAIL
Ventilator Initialization Error	After power on, CPU board cannot send the parameter settings to the ventilator control board.	1. Repeat the test. 2. Please contact Mindray Technical Support if the problem persists.	High	Startup	Non-Functional
Ventilator Initialization: Time out	Self-test result cannot be obtained due to an internal communication error.		High	Startup	Non-Functional
Drive Gas Pressure Low	Drive Gas Pressure is low.	1. Connect the drive gas pipeline. 2. Check that until drive gas pressure become normal.	High	Startup	All
O₂ Supply Failure	O ₂ Supply Failure.	1. Connect the O ₂ pipeline. 2. Check that until O ₂ supply pressure become normal.	High	Startup	All
Power Supply Voltage Error	Power supply voltage error.	1. Repeat the test. 2. Please contact Mindray Technical Support if the problem persists.	High	Startup	Manual Only
RT Clock Needs Battery	There is no button battery cell available in the system, or the button battery cell power is depleted.	1. Repeat the test. 2. Please contact Mindray Technical Support if the problem persists.	High	Startup	All
RT Clock Failure	RT chip malfunction.		High	Startup	All
Keyboard Self Test Error	Keyboard Self Test Error.	1. Repeat the test. 2. Please contact Mindray Technical Support if the problem persists.	High	Startup	Non-Functional
Keyboard Self Test: Time out	Keyboard Self Test result cannot be obtained due to communication error.		High	Startup	Non-Functional
AG Self Test Error	AG module self-test failure.	1. Repeat the test. 2. Please contact Mindray Technical Support if the problem persists.	Low	Startup	All
AG: Time out	External AG self test result cannot be obtained due to communication error.		Low	Startup	All

Table 8-4 Startup Alarm Messages

INFORMATION	CAUSE	ACTION	ALARM PRIORITY	MACHINE MODE WHEN CHECKED	STARTUP RESULT IF FAIL
Internal AG Error 02	Internal AG Module Self Test failure.	1. Repeat the test. 2. Please contact Mindray Technical Support if the problem persists.	Low	Startup	All
Internal AG: Time out	Internal AG self test result cannot be obtained due to communication error.		Low	Startup	All
AGSS Self Test Error	AGSS self-test failure.	1. Repeat the test. 2. Please contact Mindray Technical Support if the problem persists.	Low	Startup	All

Table 8-4 Startup Alarm Messages

8.8.2.2 CPU Board Runtime Alarm

INFORMATION	CAUSE	ACTION	ALARM PRIORITY	MACHINE MODE WHEN CHECKED	DISABLE IN STANDBY MODE
IP Address Conflict	The IP address of the anesthesia system is the same as the IP address of another device in the local network.	Check the IP setting.	Medium	Runtime	No
Manual Only	POST test failed and the result is [Manual Only].	1. Repeat the test. 2. Please contact Mindray Technical Support if the problem persists.	Medium	Runtime	No
Manual Only - Leak Test Fail	Circuit leakage test failed and the result is [Manual Only].		Medium	Runtime	No
Auto Ventilation is Non-Functional	The system's Auto Ventilation mode is not available.		High	Runtime	/
Status Screen Comm Stop	The CPU board lost communication with the status screen.	Please contact Mindray Technical Support.	High	Runtime	No
HFNC Module Comm Stop	The CPU board lost communication with the HFNC module.	Please contact Mindray Technical Support.	High	Runtime	No
Storage Error	Data storage error.	Please contact Mindray Technical Support.	Low	Runtime	No

Table 8-5 CPU Board Runtime Alarm Messages

8.8.2.3 Power Supply Board Runtime Alarm

INFORMATION	CAUSE	ACTION	ALARM PRIORITY	MACHINE MODE WHEN CHECKED	DISABLE IN STANDBY MODE
Power System Comm Stop	Lost communication with CPU board for 10 seconds.	Please contact Mindray Technical Support.	High	Runtime	No
Power Supply Voltage Error	Power supply voltage error.		High	Runtime	No
Low Battery Voltage!	Battery voltage is low.	1. Check the power supply. 2. Connect AC power immediately.	High	Runtime	No
System going DOWN, Battery depleted!	Battery voltage is too low.	1. Connect AC power immediately. 2. In emergency, please use Manual ventilation.	High	Runtime	No
Battery Undetected	Battery undetected.	Please contact Mindray Technical Support.	Medium	Runtime	No
Battery in Use	AC power fail.	Connected to AC power source.	Low	Runtime	No
Heating Module Failure	1. The temperature difference between the two resistances is large. 2. The temperature of one of the resistances is too high.	Please contact Mindray Technical Support.	Low	Runtime	No
Battery Failure	Battery failure.	Please contact Mindray Technical Support.	High	Runtime	No

Table 8-6 Power Supply Board Runtime Alarm Messages

NOTE: If the power supply board loses communication with the CPU board for 10 seconds, the alarm buzzer will be turned on.

8.8.2.4 Flow Control System Runtime Alarm

INFORMATION	CAUSE	ACTION	ALARM PRIORITY	MACHINE MODE WHEN CHECKED	DISABLE IN STANDBY MODE
Electronic Flow Control Error	Power supply voltage abnormality, valve fault, flow sensor fault, flow abnormality of output fresh gas, etc.	Please contact Mindray Technical Support.	Medium	Runtime	No
No Fresh Gas	The flow rate of O ₂ and balance gas is zero continuously for five seconds.	1. Check the O ₂ source and the balance gas source are connected correctly. 2. Check fresh gas setting.	Medium	Runtime	Yes
O₂ Branch Flow not Achieved	The measured flow of the O ₂ branch exceeds the target flow threshold for the O ₂ branch.	1. Check O ₂ source is connected correctly. 2. Please contact Mindray Technical Support if the problem persists.	Low	Runtime	Not applicable *
Balance Gas Branch Flow not Achieved	The measured flow of the balance gas branch exceeds the target flow threshold for the balance gas branch.	1. Check balance gas source is connected correctly. 2. Please contact Mindray Technical Support if the problem persists.	Low	Runtime	Not applicable *
Flowmeter Comm Stop	Lost communication with CPU board for 10 seconds.	Please contact Mindray Technical Support.	Medium	Runtime	No
Total Flow Sensor Self Test Time Out	The automatic flow sensor self-test times out	Please contact Mindray Technical Support.	Medium	Runtime	No
Backup Flow Control System is enabled	The backup flow control system is in use.	The backup flow control system is in use.	Low	Runtime	No
Backup Flow Control System Error	1. BFCS two-way valve fault. 2. The micro switches at the two locations of the mechanical gate are in inconsistent status.	Please contact Mindray Technical Support.	Medium	Runtime	No
Air Supply Failure	Air Supply Pressure Low.	Connect the air pipeline.	Medium	Runtime	No

Table 8-7 Electronic Flow Control System Runtime Alarm Messages

INFORMATION	CAUSE	ACTION	ALARM PRIORITY	MACHINE MODE WHEN CHECKED	DISABLE IN STANDBY MODE
N₂O Supply Failure	N ₂ O supply pressure is low.	Connect the N ₂ O pipeline supply.	Medium	Runtime	No
* Not applicable. The alarm message does not exist within this mode and therefore it cannot be disabled or enabled.					

Table 8-7 Electronic Flow Control System Runtime Alarm Messages

8.8.2.5 Ventilator Control Board Runtime Alarm

INFORMATION	CAUSE	ACTION	ALARM PRIORITY	MACHINE MODE WHEN CHECKED	DISABLE IN STANDBY MODE
Aux Control Module Comm Stop	Lost communication with CPU board for 10 seconds.	Please contact Mindray Technical Support.	High	Runtime	No
Ventilator Voltage Error	Ventilator voltage error.		High	Runtime	No
PEEP Valve Failure	1. PEEP valve voltage error. 2. PEEP valve pressure error.		Medium	Runtime	No
Insp Valve Failure	1. Inspiratory valve voltage error. 2. Inspiratory valve flow error.		Medium	Runtime	No
Safety Valve Failure	Safety valve voltage error.		Medium	Runtime	No
Flow Sensor Failure	1. Inspiratory flow is out of range. 2. Expiratory flow is out of range.		Low	Runtime	No
Check Flow Sensors	1. Inspiratory reverse flow. 2. Expiratory reverse flow.	1. Check whether the check valves are OK. 2. Please contact Mindray Technical Support if the problem persists.	High	Runtime	N/A *
Pinsp Not Achieved	The Pinsp failed to reach the Pinsp setting in the pressure mode.	1. Check ventilation settings: Pinsp/ Δ Pinsp, Δ Psupp, PEEP, etc. 2. Check whether the breathing tube is leaking. 3. Solve the [Paw Too High] alarm.	Low	Runtime	N/A *

Table 8-8 Ventilator Control Board Runtime Alarm Messages

INFORMATION	CAUSE	ACTION	ALARM PRIORITY	MACHINE MODE WHEN CHECKED	DISABLE IN STANDBY MODE
Vt Not Achieved	The Vt does not reach the Vt setting in volume mode.	1. Check ventilation settings: Vt, Plimit, etc. 2. Check whether patient circuit is leaking or blocked. 3. Solve the [Pressure Limit] alarm and [Paw Too High] alarm.	Low	Runtime	N/A *
ACGO 3-way Valve Failure	ACGO 3-way valve status error.	Please contact Mindray Technical Support.	Medium	Runtime	No
Pressure Monitoring Channel Failure	For auxiliary control module: The monitoring value of the PEEP sensor or pressure sensor is out of range. For ventilator control board: 1. The monitoring value of the PEEP sensor or pressure sensor is out of range. 2. The zero point of the PEEP sensor or pressure sensor is abnormal.		Medium	Runtime	No
Aux Control Module Voltage Error	Auxiliary control module voltage error.		Low	Runtime	No
Breathing Circuit Not Installed	Breathing Circuit is not installed.	Install the breathing circuit.	High	Runtime	No
Volume Exchanger not Installed	The volume exchanger is not installed.	Install the volume exchanger.	High	Runtime	No
Vaporizer Dock Failure	1. Bypass fault. 2. Fresh gas inlet or outlet valve fault.	Please contact Mindray Technical Support.	High	Runtime	No
Auto/Manual Switching Failure	1. Auto/Manual position switch failure. 2. Auto/Manual valve failure.	Please contact Mindray Technical Support.	High	Runtime	No

Table 8-8 Ventilator Control Board Runtime Alarm Messages

INFORMATION	CAUSE	ACTION	ALARM PRIORITY	MACHINE MODE WHEN CHECKED	DISABLE IN STANDBY MODE
Des Vaporizer Lock Device Failure	Vaporizer lock device failure	Please contact Mindray Technical Support.	High	Runtime	No
Iso Vaporizer Lock Device Failure			High	Runtime	No
Sev Vaporizer Lock Device Failure			High	Runtime	No
Patient Circuit Leak	1. Circuit leak. 2. The patient is not connected.	Check whether the patient circuit is leaking or disconnected.	Medium	Runtime	N/A *
CO₂ Absorber Canister Not Locked	CO ₂ absorber canister is not installed.	1. Check whether CO ₂ absorber canister is correctly installed and locked. 2. Re-install the CO ₂ absorber canister. 3. Please contact Mindray Technical Support if the problem persists.	High	Runtime	No
O₂ Sensor Disconnected	The AG module and the O ₂ sensor are not connected.	Connect O ₂ cell or plug in external AG module.	Low	Runtime	No
Replace O₂ sensor	O ₂ sensor is exhausted.	Replace the O ₂ sensor.	Medium	Runtime	No
Calibrate O₂ sensor for 100%	O ₂ value is greater than 110% or between 5% and 15% for 4 seconds.	Calibrate the O ₂ sensor.	Low	Runtime	No
Ventilator Control Board Communication Stopped	Lost communication with CPU board for 10 seconds.	Please contact Mindray Technical Support.	High	Runtime	No
Drive Gas Pressure Low	Drive Gas Pressure is low.	1. Connect the drive gas pipeline. 2. In emergency, please use Manual ventilation.	High	Runtime	No
O₂ Supply Failure	O ₂ Supply Failure.	Connect the O ₂ pipeline.	High	Runtime	No

Table 8-8 Ventilator Control Board Runtime Alarm Messages

INFORMATION	CAUSE	ACTION	ALARM PRIORITY	MACHINE MODE WHEN CHECKED	DISABLE IN STANDBY MODE
Fresh Gas Flow Too High	In VCV and SIMV-VC modes, the flow rate of fresh gas is greater than or equal to the desired flow rate.	1. Check fresh gas flow setting. 2. Check ventilation settings: Vt, Tinsp, etc.	Low	Runtime	N/A *

* Not applicable. The alarm message does not exist within this mode and therefore it cannot be disabled or enabled.

Table 8-8 Ventilator Control Board Runtime Alarm Messages

8.8.2.6 AG Module Alarm Messages

INFORMATION	CAUSE	ACTION	ALARM PRIORITY	MACHINE MODE WHEN CHECKED	DISABLED IN STANDBY MODE
AG Module Error	AG module failure.	Please contact Mindray Technical Support.	High	Runtime	No
O₂ Sensor Error	Paramagnetic O ₂ sensor error.		High	Runtime	Yes
AG No Watertrap	The AG module watertrap was installed improperly or not installed.	Check the connections of the watertrap and re-connect it.	Low	Runtime	Yes
AG Change Watertrap	Change the AG watertrap.	Replace the AG watertrap.	Low	Runtime	Yes
AG Airway Occluded	Flow rate is lower than 20 ml/min for 1 second.	1. Check whether airway is kinked or blocked. 2. Replace the airway. 3. Re-plug the module. 4. Please contact Mindray Technical Support if the problem persists.	Low	Runtime	Yes
AG Zero Failed	Gas measurements is of poor accuracy during zeroing.	1. Check for external interference sources. 2. Check whether there is a [AG Airway Occluded] alarm, remove the occlusion. 3. Re-plug the module. 4. Please contact Mindray Technical Support if the problem persists.	Low	Runtime	Yes

Table 8-9 AG Module Alarm Messages

INFORMATION	CAUSE	ACTION	ALARM PRIORITY	MACHINE MODE WHEN CHECKED	DISABLED IN STANDBY MODE
Mixed Agent	MAC < 3	Please use the purge agent function to purge the residual anesthetic gas in the circuit.	Low	Runtime	Yes
	Mixed agents are detected but MAC is an invalid value.		Medium	Runtime	Yes
Mixed Agent and MAC ≥ 3	MAC ≥ 3.		Medium	Runtime	Yes
Incompatible AG Software Version	Incompatible version found for the AG module.	Replace the AG module.	High	Runtime	No
CO₂ Over Range	The monitoring value exceeds the measurable range.	1. Calibrate the AG module. 2. Please contact Mindray Technical Support if the problem persists.	Low	Runtime	Yes
N₂O Over Range					
ISO Over Range					
SEV Over Range					
DES Over Range					
O₂ Over Range					
awRR Over Range					
Internal AG Error 01	1. Internal AG hardware error. 2. Internal AG self-test error. 3. Internal AG hardware fault. 4. Internal AG initialization error. 5. Internal AG communication stopped.	Please contact Mindray Technical Support.	Low	Runtime	Yes
Internal AG Error 02	Internal AG Zero Failed.				
Internal AG Error 03	Internal AG No Water trap.				
Internal AG Error 04	Internal AG airway occluded.				
Internal AG Error 05	Internal AG Change Water trap.				

Table 8-9 AG Module Alarm Messages

8.8.2.7 AGSS Alarms

INFORMATION	CAUSE	ACTION	ALARM PRIORITY	MACHINE MODE WHEN CHECKED	DISABLED IN STANDBY MODE
Scavenging Flow is Too High	The AGSS flow rate is higher than the upper limit.	Set the vacuum flow so that the float position is between the Min and Max lines.	Low	Runtime	No
AGSS Failure	AGSS failure.	Please contact Mindray Technical Support.	Medium	Runtime	No

Table 8-10 AGSS Alarms

8.8.2.8 Vaporizer alarms

NOTE: AA stands for any of the following anesthetic agents: Des (Desflurane), Iso (Isoflurane), and Sev (Sevoflurane).

INFORMATION	CAUSE	ACTION	ALARM PRIORITY	MACHINE MODE WHEN CHECKED	DISABLED IN STANDBY MODE
AA Vaporizer Liquid Level Low	Liquid level lower than 50 ml.	Please fill in the drug.	Low	Runtime	No
AA Vaporizer Almost Empty	Liquid level lower than the min level.	Please fill in the drug.	Medium	Runtime	No
AA Not Delivered - Lid is Open	Vaporizer lid is opened for more than 2 minutes.	Close the vaporizer lid.	High	Runtime	No
AA Vaporizer Failure	Vaporizer failure.	Replace the vaporizer or contact Mindray Technical Support.	High	Runtime	No
AA Vaporizer Selftest Error	Vaporizer self-test error.	1. Re-install or replace the vaporizer. 2. Please contact Mindray Technical Support if the problem persists.	High	Runtime	No
AA Vaporizer Comm Stop	The vaporizer lost communication with the CPU board for 10 seconds.	1. Re-install or replace the vaporizer. 2. Please contact Mindray Technical Support if the problem persists.	High	Runtime	No

Table 8-11 Vaporizer alarms

INFORMATION	CAUSE	ACTION	ALARM PRIORITY	MACHINE MODE WHEN CHECKED	DISABLED IN STANDBY MODE
AA Vaporizer Output Abnormal	Abnormality in vaporizer output concentration.	Replace the vaporizer or contact Mindray Technical Support.	High	Runtime	Yes
O₂ Supply Failure, AA Vaporizer Stopped	O ₂ pressure is insufficient, causing the vaporizer to stop working.	1. Connect the O ₂ pipeline. 2. Check the pressure until the O ₂ pressure restores to the normal level.	High	Runtime	Yes

Table 8-11 Vaporizer alarms

8.8.2.9 HFNC Module Alarms

INFORMATION	CAUSE	ACTION	ALARM PRIORITY	MACHINE MODE WHEN CHECKED	DISABLED IN STANDBY MODE
HFNC Module Failure	1. O ₂ branch flow sensor error. 2. Air branch flow sensor error.	Please contact Mindray Technical Support.	Medium	Runtime	No
HFNC Selftest Error	1. EEPROM self-test error. 2. O ₂ proportional valve self-test error. 3. Air proportional valve self-test error. 4. Zero reading error.	1. Restart HFNC. 2. Please contact Mindray Technical Support if the problem persists.	Medium	Runtime	No
Calibrate HFNC Module	1. Calibration table isn't found in EEPROM. 2. Checksum of the calibration table does not match.	Please contact Mindray Technical Support.	Low	Startup	No

Table 8-12 HFNC Module Alarms

8.8.3 Prompt Message

8.8.3.1 Prompt Messages Displayed in Alarms Area

INFORMATION	REMARK
Volume and Apnea Alarms are OFF	This message appears when the [Alarms] is set to [Off] in the Manual mode.
CO₂ and CO₂ Apnea Alarms are OFF	This message appears when [CO₂ Alarms] is set to [Off] in the Manual mode.
Load Configuration Failure	This message appears when loading user or latest configuration failed.
Save Profile Failure	This message appears when an error occurs during saving user profiles.

Table 8-13 Prompt Messages Displayed in Alarms Area

INFORMATION	REMARK
DEMO Mode - Not for Clinical Use	This message appears when the system works in the demo mode.
Service Mode - Not for Clinical Use	This message appears when the machine is working in Service Mode.
Mainboard Reset	This message appears when the mainboard is restarted abnormally.
Ventilator Reset	This message appears when the ventilator is restarted abnormally.
Aux Control Module Reset	This message appears when the auxiliary monitoring board is restarted abnormally.
Vaporizer Reset	This message appears when the vaporizer is restarted abnormally.
AA Not Delivered - Lid is Open	This message appears when vaporizer lid is opened for less than 2 minutes.
Apnea Ventilation	This message appears when Apnea Ventilation is triggered in the PS/CPAP mode.
Calibrate O₂ sensor for 21%	This message appears when more than 72 hours have elapsed since the last successful calibration.
Calibrate O₂ sensor for 100%	This message appears when the O ₂ Sensor 100% Calibrate data is not revised correctly after 21% O ₂ sensor calibration is successful.
Auto-zero in process	This message appears when auto-zeroing of the pressure sensors is in process.
New functions activated, please restart!	This message appears when function activation completes successfully.
Restart to Activate New Flowmeter Standard	This message appears when Flowmeter Standard is changed.
Could not locate time server	This message appears when the SNTP Protocol is set to On but has not communicated with the time server for 5 intervals.
Total Flow Sensor Self Test in Progress	This message appears when an automatic total flow sensor self-test is in progress.
Leak Test Not Performed	This message appears when the Auto Leak Test or Manual Leak Test is skipped after system startup, or 24 hours has elapsed since last leak test.
Ventilation and Fresh Gas Flow Paused	This message displays when the Flow Pause is active..
All Physiological Alarms are OFF	This message displays when the Flow Pause is active..
CO₂ Data is Unavailable for Optimizer	This message appears when the OPTIMIZER® indicator feature for fresh gases is enabled but the CO ₂ data is invalid.
Fresh Gas Sample Check in Progress	This message appears when the AG module is performing time-sharing sampling.
Fresh Gas Flow is Too Low	This message appears when the fresh gas flow is too low.
AG Loaded Successfully	External AG loaded successfully.
AG Unloaded Successfully	External AG unloaded successfully.
AG Startup	AG module is starting up.
AG Warmup	AG module is warming up.
AG Zeroing	AG module zeroing in progress.

Table 8-13 Prompt Messages Displayed in Alarms Area

This page intentionally left blank.

Maintenance

Maintenance Schedule	9-3
Breathing System Service	9-3
Flow Sensor Calibration	9-4
O ₂ Sensor Calibration	9-4
Handling of Gathered Water	9-7
Electrical Safety Inspection	9-7
Cleaning and Disinfection	9-8
Periodic Maintenance	9-29

-
- WARNING:** Do not use a malfunctioning anesthesia system. Have all repairs and service done by an authorized service representative.
- WARNING:** Use a cleaning and disinfection schedule that conforms to your institution's disinfection and risk-management policies.
- Refer to the material safety data sheet as applicable.
 - Refer to the operation and maintenance manuals of all disinfection equipment.
 - Do not inhale fumes produced during any disinfection process.
- WARNING:** Use extreme care while handling the CO₂ absorbent as it is a caustic irritant.
- WARNING:** Only use lubricants approved for anesthesia or O₂ equipment.
- WARNING:** Do not use lubricants that contain oil or grease. They can burn or explode in the presence of high O₂ concentrations.
- WARNING:** Obey infection control and safety procedures. Utilized equipment may contain blood and body fluids.
- WARNING:** Movable parts and removable components may present a pinch or a crush hazard. Use care when moving or replacing system parts and components.
- CAUTION:** To prevent system damage:
- Refer to the documentations provided by the manufacturer of the cleaning agent.
 - Never use organic, halogenated or petroleum-based solvents, anesthetic agents, glass cleaning agents, acetone or other irritant agents.
 - Never use abrasive agents (i.e. steel wool or silver polish) to clean components.
 - Keep all liquids away from electronic components.
 - Prevent liquid from entering the equipment.
 - All cleaning solutions used must have a pH value between 7.0 and 10.5.
- CAUTION:** Never immerse the oxygen sensor or its connector into any type of liquid. Dispose the O₂ sensor according to the manufacturer's specifications.
- CAUTION:** Do not wash the inner surface of the oxygen sensor.
- CAUTION:** Do not perform soaking or high-temperature processing on the O₂ sensor.
- NOTE:** No repair should ever be attempted by anyone not having experience in the repair of devices of this nature. Replace damaged parts with components manufactured or sold by Mindray. Then test the unit to ensure that it complies with the manufacturer's published specifications.
- NOTE:** If necessary, contact Mindray for the circuit diagram, list of parts and calibration instructions of products or other information related to equipment maintenance.

9.1 Maintenance Schedule

The schedules listed below are the minimum frequency based on 2,000 hours of usage per year. The equipment should be serviced more frequently if used more than this yearly usage. Maintenance should be performed by a trained technician.

NOTE: **During cleaning and setup, inspect the parts and seals for damage. Replace or repair as necessary.**

MINIMUM MAINTENANCE FREQUENCY	MAINTENANCE
Every day	Clean the external surfaces.
Every 72 hours	Perform the 21% O ₂ calibration to keep O ₂ sensor accuracy for the anesthesia system not connected to the air supply. The anesthesia system not connected to the air supply cannot automatically perform O ₂ sensor calibration when powered on.
Every 30 days	Visually check the equipment to ensure that worn or damaged parts are replaced in a timely manner.
Every year	Perform periodic maintenance by a trained technician. Gas Bench calibration. Contact Mindray Technical Support for details.
Every three years	Replace the internal lead-acid cell and button cell. Perform periodic maintenance by a trained technician. Contact Mindray Technical Support for details.
On-demand	<ul style="list-style-type: none"> • Calibrate the O₂ sensor after replacing the O₂ sensor or when there is a larger error in O₂ concentration monitoring. • Replace the O₂ sensor if it cannot be calibrated. • Replace the soda lime in the canister if the soda lime color changes. Follow the manufacturer's instructions. • Replace the flow sensor if the seal for the flow sensor is damaged, the membrane inside the flow sensor is cracked or distorted, or the flow sensor is cracked or distorted. • Calibrate the flow sensor after re-installing the cleaned or disinfected flow sensor, after replacing with a new flow sensor, or when tidal volume measurement is inaccurate. • Clear the water gathered in the breathing system watertrap and the gas module watertrap.

Table 9-1 Maintenance schedule

9.2 Breathing System Service

When cleaning the breathing system, replace any parts that are visibly cracked, chipped, distorted or worn. For details, refer to "Inspect the System" on Pages 5-5 and "Cleaning and Disinfection" on Pages 9-8 for specific operations.

9.3 Flow Sensor Calibration



WARNING: Do not calibrate the flow sensor when the system is connected to a patient.

NOTE: During calibration, do not operate the pneumatic parts. Do not move or press the breathing tubes.

NOTE: Calibrate the flow sensor after re-installing the cleaned or disinfected flow sensor, after replacing with a new flow sensor, or when tidal volume measurement is inaccurate.

The flow sensor must be calibrated whenever the flow volume is out of specification or after changing the flow sensor.

To calibrate the flow sensor:

1. Ensure that the gas supply pressure is normal.
2. Turn off all fresh gas inputs.
3. Connect the Y piece on the breathing circuit to the leak test port to close the breathing system.
4. Remove the watertrap.
5. Ensure that the system is in Standby mode.
6. Select the  icon, and open the [Setup] menu.
7. Select the [Calibrate] soft key.
8. Follow the on-screen prompts. Select the [Begin] key to calibrate the flow sensor. The calibration may take several minutes. The system will display the results of the calibration status after the process is completed.
9. Select  to close the menu.
10. After the calibration is complete, install the watertrap.

NOTE: In case of repeated calibration failure, contact Mindray Technical Support.

9.4 O₂ Sensor Calibration

WARNING: Do not perform the calibration when the system is connected to a patient.

WARNING: To calibrate an O₂ sensor, the ambient pressure must be identical with the ambient pressure for O₂ transport monitoring of the breathing system. Otherwise, the monitoring may exceed the specified range.

WARNING: Prior to the O₂ sensor calibration, remove the O₂ sensor. Make sure there is no water on the O₂ sensor or where it is installed before installing the O₂ sensor.

WARNING: No O₂ calibration is required if O₂ sensor is not equipped or not used.

WARNING: Observe related biohazard regulations during disposal of discarded O₂ sensors. Do not burn O₂ sensors.

9.4.1 21% Oxygen Calibration



It is required to check the 21% O₂ calibration once around every 72 hours to keep O₂ sensor accuracy for the anesthesia system not connected to the air supply.

NOTE: The breathing system automatically seals off the O₂ sensor port when the O₂ sensor is removed.

1. Select the  icon > [O₂] soft key.
2. Remove the O₂ sensor from the O₂ sensor port on the breathing system. Allow three (3) minutes for the sensor to acclimate to the environment.
3. Carefully follow the on-screen prompts to prepare for calibration.
4. Select the [Begin] key to start the O₂ sensor calibration. The system will display the calibration status after calibration has completed.
5. If an error code (such as 00 00 00 10) is displayed in red, see "O₂ sensor calibration error codes", Table 9-2 on Pages 9-6 to learn more about troubleshooting. When the 21% O₂ calibration is complete, reinstall the O₂ sensor to the O₂ sensor port on the breathing system.

9.4.2 100% O₂ Calibration

When the measured O₂ concentration evidently diverges from other reference values, or when the O₂ sensor is replaced, the sensor should be calibrated. When the O₂ sensor is replaced, 100% O₂ calibration is required.

1. Make sure that the anesthesia system is in the standby mode.
2. Select the  icon > [System] (system password required) > [Calibrate] > [O₂ Sensor] soft key.
3. Make sure that no [O₂ Supply Failure] alarm appears.
4. Carefully follow the on-screen prompts to prepare for calibration.
5. Select the [Begin] key to start the 100% O₂ sensor calibration. The system will prompt the calibration status after calibration has completed.
6. If error code (such as 00 00 00 10) is displayed in red, see "O₂ sensor calibration error codes", Table 9-2 on Pages 9-6 to learn more about troubleshooting.
7. After the calibration is complete, select  to close the menu.

NOTE: If the 100% O₂ calibration failed, check for any technical faults and alarms. After the fault is cleared, calibrate the sensor again.

NOTE: If the calibration failed for several times, replace the O₂ sensor and calibrate the sensor again. If the calibration failure persists, contact Mindray Technical Support.

9.4.3 O₂ Sensor Calibration Error Codes

ERROR CODE	DESCRIPTION	RECOMMENDED COUNTERMEASURES
1	21% calibration value is smaller than 249	<ol style="list-style-type: none"> 1. Check that the O₂ sensor is connected to the cable correctly. 2. Check that the O₂ sensor is in 21 % O₂. 3. Check that the O₂ sensor output voltage in the calibration menu is steady. 4. Replace the O₂ sensor.
2	21% calibration value is greater than 523	<ol style="list-style-type: none"> 1. Check that the O₂ sensor is connected to the cable correctly. 2. Check that the O₂ sensor is in 21 % O₂. 3. Check that the O₂ sensor output voltage in the calibration menu is steady. 4. Replace the O₂ sensor.
3	100% calibration value is smaller than 1301	<ol style="list-style-type: none"> 1. Check that the O₂ sensor is connected to the cable correctly. 2. Check the O₂ supply pressure. 3. Check that the O₂ sensor output voltage in the calibration menu is steady. 4. Replace the O₂ sensor.
4	100% calibration value is greater than 2378	<ol style="list-style-type: none"> 1. Check that the O₂ sensor is connected to the cable correctly. 2. Check the O₂ supply pressure. 3. Check that the O₂ sensor output voltage in the calibration menu is steady. 4. Replace the O₂ sensor.
5	Difference between 21% calibration value and 100% calibration value exceeds the threshold	Replace the O ₂ sensor.
6	Error in correcting 100% calibration value using 21% calibration value	<ol style="list-style-type: none"> 1. Replace the O₂ sensor. 2. Perform the calibration again. 3. Replace the CPU board.
7	System in BFCS status	Set the system to the EFCS status.
33	O ₂ supply pressure low	<ol style="list-style-type: none"> 1. Replace or connect the gas supply. 2. If the gas supply functions normally, check the gas supply pressure switch.
35	Air supply pressure low	<ol style="list-style-type: none"> 1. Replace or connect the gas supply. 2. If the gas supply functions normally, check the gas supply pressure switch.
37	O ₂ Sensor Disconnected	<ol style="list-style-type: none"> 1. Check for any [O₂ Sensor Disconnected] alarm on the screen. If you see the alarm, check whether the O₂ sensor cable is connected correctly. 2. Check that the O₂ sensor output voltage in the calibration menu is steady. 3. Replace the O₂ sensor.
38	O ₂ sensor failure	<ol style="list-style-type: none"> 1. Check for any [Replace O₂ Sensor] alarm on the screen. If you see the alarm, check whether the O₂ sensor cable is connected correctly. 2. Check that the O₂ sensor output voltage in the calibration menu is steady. 3. Replace the O₂ sensor.

Table 9-2 O₂ sensor calibration error codes

ERROR CODE	DESCRIPTION	RECOMMENDED COUNTERMEASURES
39	Failure to save table	1. Perform the calibration again. 2. Replace the CPU board.
3B	ACGO switched on	Turn off the ACGO switch.

Table 9-2 O₂ sensor calibration error codes

9.5 Handling of Gathered Water

9.5.1 Avoid Water Gathering

Water comes from the condensation of exhaled gas and a chemical reaction between CO₂ and the soda lime in the CO₂ absorbent canister. At lower fresh gas flows more water builds up because of the following:

- More CO₂ stays in the CO₂ absorbent canister to react and produce water.
- More moist, exhaled gas stays in the breathing system and CO₂ absorbent canister to produce condensed water.

When the anesthesia system is in use, water build-up inside the flow sensor, watertrap, gas module watertrap, and patient tube could result in abnormal flow waveform, unstable tidal volume or inaccurate measured value of gas. If there is water build-up, clear it immediately before use.

To prevent water build-up:

- Increase the fresh gas flow as appropriate. More water may be gathered when the fresh gas flow is lower than the OPTIMIZER®, and less water is gathered when the fresh gas flow is higher than the OPTIMIZER®.
- Enable breathing circuit heating can help reduce the gathered water in the circuit, but the water gathered in the breathing tube may increase on the contrary.
- Use a filter between the flow sensor and the patient to limit water condensation in the flow sensor.

9.5.2 Clear Gathered Water

Water build-up inside the flow sensor, watertrap, gas module watertrap, and patient tube results in abnormal flow waveform, unstable tidal volume or inaccurate measured value of gas. If there is water built up inside these parts, clear the water, then reinstall the parts for use.

WARNING: Check water build-up inside the flow sensor before every system use. Accumulated water in the flow sensor causes erroneous readings.

WARNING: Ensure that all breathing system parts are completely dried after the breathing system is cleaned and disinfected.

WARNING: Water may gather in the patient's breathing tube if the Auto Ventilation mode is used for a long time (such as longer than four hours). Clear the gathered water in time to avoid impact on the ventilation or ingress of water into the patient circuit.

9.6 Electrical Safety Inspection

NOTE: Perform electrical safety inspection after servicing or maintenance. Before the electrical safety inspection, make sure all the covers, panels, and screws are correctly installed.

NOTE: The electrical safety inspection should be performed once a year.

9.6.1 Auxiliary Outlet Test

Verify that the mains power voltage appears on each auxiliary outlet when the anesthesia system is connected to the mains power.

9.6.2 Electrical Safety Test

1. Perform protective earth resistance test:
 - a. Connect the two probes for testing the grounding impedance of the safety analyzer to the protective grounding terminal and equipotentiality of the AC power supply respectively.
 - b. Test the grounding impedance using a 25A testing current.
 - c. Verify that the impedance value is not greater than 0.1 ohms (100mohms).
 - d. Connect the two probes for testing the grounding impedance of the safety analyzer to the protective grounding terminal of the AC power supply and the protective grounding terminal of any auxiliary outlet respectively, and repeat Steps b and c.
 - e. If the impedance value is greater than 0.1ohms (100mohms) but smaller than 0.2ohms (200mohms), remove the AC power cable, and connect the probe that was originally connected to the protective grounding terminal of the AC power supply to the protective grounding terminal of the AC power outlet. Then repeat Steps a to d.
2. Test the earth leakage currents in the following circumstances:
 - Normal polarity
 - Reverse polarity
 - Open neutral, normal polarity
 - Open neutral, reverse polarity
3. Verify that the maximum leakage current in the first two circumstances does not exceed 500 μ A (0.5mA), and that in the last circumstance does not exceed 1000 μ A (1mA).

NOTE: Please use a certified safety analyzer (such as UL, CSA or AAMI) and perform related tests following their respective instructions.

WARNING: Leakage current tests are required when the normal saline or blood spills and after the start of each monitoring. A leakage current test is required immediately after a major surge appears in the residential electrical system.

WARNING: Keep in mind that liquids similar to normal saline and Ringer's solution and blood are excellent conductors. Avoid touching any part of the system using a wet hand. Always operate using clean and dry hands.

9.7 Cleaning and Disinfection

ISO 17664 compliance:

The autoclaving process of the Anesthetic Breathing System has been tested and found to be in compliance with ISO 17664:2017. Compliance to ISO 17664:2017 only applies when bacterial/viral filters are used to filters air coming in from the patient and returning air to the patient. Filters must be properly installed. Refer to 9.7.3 "Breathing System" and "9.7.1 "Cleaning Agents and Disinfectors/Autoclaving".

WARNING: Stop using the equipment and contact your service personnel if the housing is damaged to avoid electric shock and injury.

CAUTION: Before using the anesthesia system after cleaning or disinfecting, power on the system and follow the on-screen prompts to perform leak test and compliance test. See (Pages 5-7) 5.4.2"Leak & Compliance Test".

NOTE: Avoid wetting the pneumatic ports and electrical devices during cleaning and disinfection process.

Follow all WARNINGS and CAUTIONS listed at the beginning of this chapter. Prior to use, refer to the facility's infection control policy to determine the frequency and level at which cleaning and disinfection should be performed. If disinfection is required, all components must first be cleaned and dried as described in the following sub-sections. For additional information about infection control practices, refer to the APIC Guidelines for Selection and Use of Disinfectants, published in the American Journal of Infection Control, Vol. 24, No. 4, August 1996.

For additional information about infection control, refer to the ASA's Recommendations for Infection Control for the Practice of Anesthesiology, second edition. For additional information on reprocessing medical devices, refer to AAMI TIR 30:2003, A compendium of process, materials, test methods, and acceptance criteria for cleaning reusable medical devices.

9.7.1 Cleaning Agents and Disinfectors/Autoclaving

The cleaning agents and disinfectors listed have been tested and found to not cause harm to the Anesthesia System parts. Read the material safety data sheet (MSDS) for each cleaning agent and disinfectant.

The cleaning agents and disinfectors listed may not be available or approved for use in all countries. Follow hospital guidelines for cleaning and cleaning agent use, disinfecting and disinfectant use.

NOTE: Cleaning and disinfecting solutions not shown in the cleaning agents and disinfectors listed must have a pH of 7.0 to 10.5. Organic, halogenated or petroleum-based solvents, anesthetic agents, glass cleaners, acetone, or other harsh cleaning agents and disinfectors are not recommended.

Clean and disinfect the system before its first use. After the system has been used, clean or disinfect it on a daily basis or regularly at a desired interval. See "Maintenance schedule", Table 9-1 on Pages 9-3 for reference.

Table 9-3 to Table 9-6 introduces the cleaning agents and disinfectors, as well as the possible high-temperature and high-pressure processing procedures for the anesthesia system.

MANUAL CLEANING AGENT

Water*

Grafco® Tincture of Green Soap

MetriZyme

* The water quality must never be less than drinking water quality.

NOTE: Recommend to refer to the manufacturer's directions for use.

Table 9-3 Manual Cleaning Agent

MANUAL DISINFECTOR

Surface disinfection	Sodium hypochlorite bleach 0.5%
	Isopropanol alcohol (70%)
	Alpet® D2 Surface Sanitizing Wipes
	PDI Super Sani-Cloth® Germicidal Disposable Wipe
	Metrex™ Cavi Wipes™
	PDI Sani-Cloth® HB Germicidal Disposable Wipe
	PDI Sani-Cloth® Plus Germicidal Disposable Cloth
Suction tubes of the negative pressure suction device	CIDEX® OPA

NOTE: Recommend to refer to the manufacturer's directions for use.

Table 9-4 Manual Disinfectant

AUTOMATED CLEANING AGENT

MetriZyme
Neodisher Mediclean Forte

Table 9-5 Automated Cleaning Agent

AUTOCLAVING PROCESS

Autoclaving process*

* Except O₂ sensors and airway pressure gauge, all the components of the breathing system are resistant to autoclaving process. The components can be autoclaved up to a maximum temperature of 134°C (273°F) for 20 minutes (recommended time).

Table 9-6 Autoclaving process

9.7.2 Exterior

Clean all exteriors (including the external surface of the Anesthesia System, the external surface of the Anesthetic Vaporizer, the external surface of the gas monitoring module, the external surface of the gas supply hose assembly, the external surface of the scavenging hose assembly and the external surface of the bracket, etc.) and cables using soft cloths moistened with an authorized cleaning agent (See Table 9-3 "Manual Cleaning Agent" on Pages 9-9).

Disinfect all exteriors (including the external surface of the Anesthesia System, the external surface of the Anesthetic Vaporizer, the external surface of the gas monitoring module, the external surface of the gas supply hose assembly, the external surface of the scavenging hose assembly and the external surface of the bracket, etc.) and cables using soft cloths moistened with an authorized disinfectant (See Table 9-4 "Manual Disinfectant" on Pages 9-10).

After the cleaning or disinfection is complete, use dry and lint-free cloths to remove the residual cleaning agent and disinfectant solution.

Check the product for visible soiling and repeat cleaning and disinfection if necessary. Check the product for visible damage and replace if necessary.

9.7.3 Breathing System

- WARNING:** Use extreme care while handling the CO₂ absorbent as it is a caustic irritant.
- CAUTION:** Never immerse the oxygen sensor or its connector into any type of liquid. Dispose the O₂ sensor according to the manufacturer's specifications.
- CAUTION:** Do not wash the inner surface of the oxygen sensor.
- CAUTION:** Do not perform soaking or high-temperature processing on the O₂ sensor.
- NOTE:** Do not use water or high pressure gas to flush the inside of the flow sensor; otherwise, the flow sensor will be damaged.
- NOTE:** Do not insert any object into the flow sensor for cleaning; otherwise, the flow sensor will be damaged.
- NOTE:** Please disassemble and clean the bottom of the CO₂ absorbent canister regularly.

9.7.3.1 Disassembly

Disassemble the Breathing System at the point of use or at the designated cleaning area.

9.7.3.1.1 Breathing Tube

- NOTE:** When removing a breathing tube, hold the joints at both ends of the tube to prevent damage to the tube.
- NOTE:** Do not reuse, reprocess, or sterilize disposable products.

1. Pull the bacteria filter off the Y-piece.

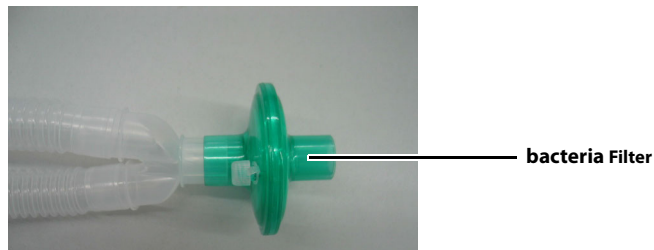

Figure 9-1 Remove the bacteria filter

2. Disconnect the expiratory tube and inspiratory tube from the expiration connector and the inspiration connector of the breathing system, respectively.



Figure 9-2 Remove the breathing tubes

9.7.3.1.2 Manual Bag

NOTE: Do not reuse, reprocess, or sterilize disposable products.

Directly draw out the manual bag to disassemble it.

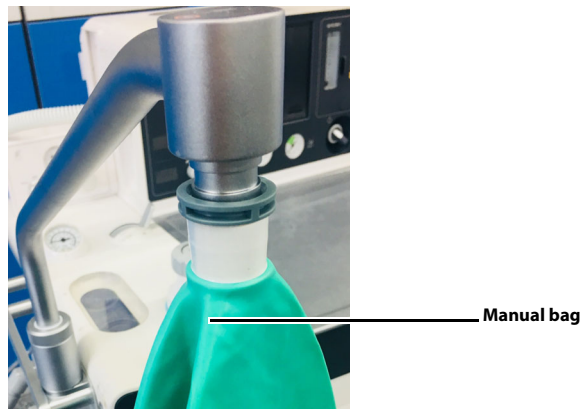

Figure 9-3 Remove the manual bag

9.7.3.1.3 O₂ Sensor

1. Press the O₂ sensor cover switch to open the O₂ sensor cover.

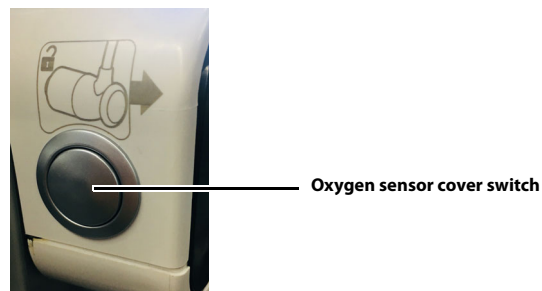

Figure 9-4 Open the O₂ sensor cover

2. Pull straight out the O₂ sensor cable from the O₂ sensor support.



Oxygen sensor cable

Figure 9-5 Remove the O₂ sensor cable

3. Press the buckle to pull out the O₂ sensor support from the breathing system..

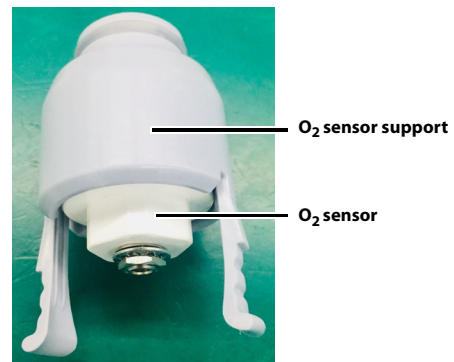

Figure 9-6 Remove the O₂ sensor support from the breathing system

4. Rotate the O₂ sensor anticlockwise to remove it from the support.



Figure 9-7 Remove the O₂ sensor from the support

5. Close the O₂ sensor cover.

9.7.3.1.4 CO2 Absorbent Canister

1. Rotate the locking mechanism handle clockwise to the unlocked position.



Unlocking position.
The bypass is turned on.

Gasket



Locking position.
The bypass is turned off.

Gasket

Figure 9-8 Canister unlocking

Figure 9-9 Canister locking

2. Remove the absorber canister.
3. Remove the Pre-Pak or loose fill absorbent from the canisters.

WARNING: Use extreme care while handling the CO2 absorbent as it is a caustic irritant.

WARNING: Please dispose of discarded absorbent following the requirements of absorbent manufacturers.

WARNING: To disassemble the bypass assembly, hold the bypass assembly up with one hand to prevent it from falling and press the buckle button on the bypass assembly with the other hand.

9.7.3.1.5 Bypass

Press and hold the buckle on the bypass assembly to take out the bypass assembly downward.

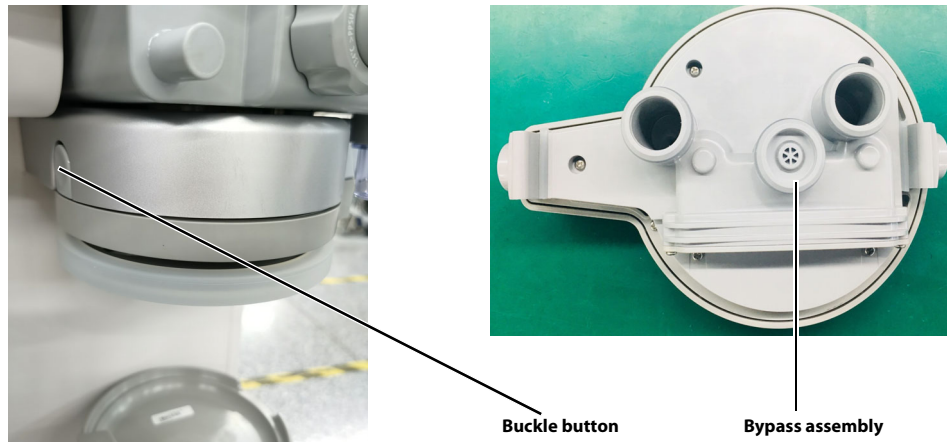

Figure 9-10 Remove bypass

9.7.3.1.6 Flow Sensor

1. Loosen the locking nut anticlockwise, remove the inspiration/expiration connector.

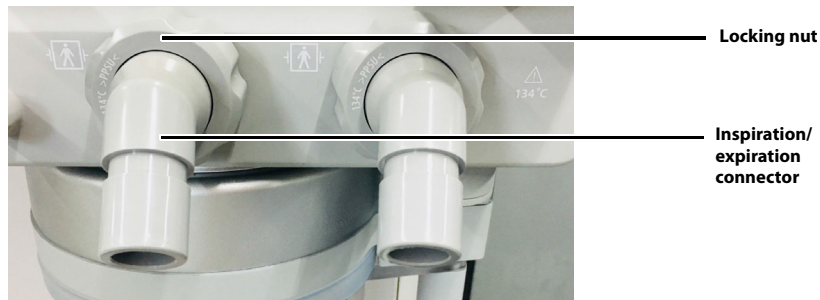

Figure 9-11 Remove the inspiration/expiration connector and locking nut

2. Remove the flow sensor from the breathing system.



Figure 9-12 Remove the flow sensor

9.7.3.1.7 Bag Arm

1. At the base of the bag arm, locate the retaining ring. Turn the ring anticlockwise until it is no longer threaded.

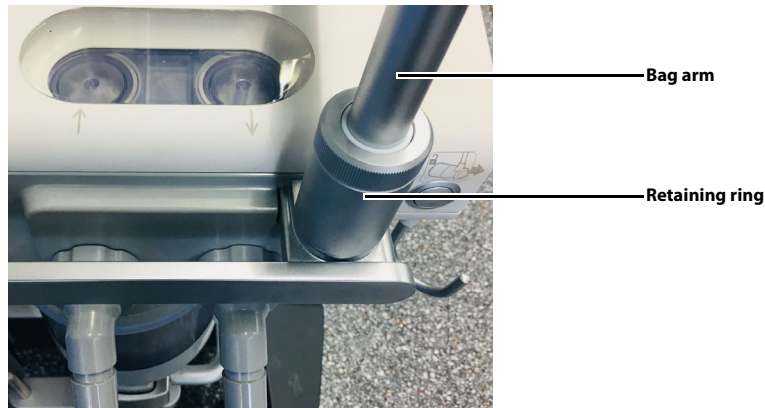

Figure 9-13 Remove the bag arm

2. Lift the bag arm from the breathing system body.

9.7.3.1.8 Breathing System Body

Hold the handrails on one side of the breathing system body, firmly separate and slide it away from its mounting arm.

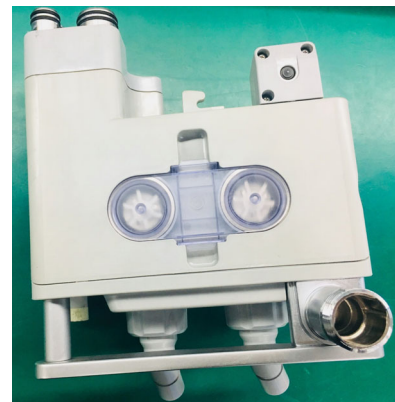

Figure 9-14 Remove the breathing system body

9.7.3.1.9 Inspiration and Expiration Valves

1. Press the buckle to remove the valve dome from the breathing system body.

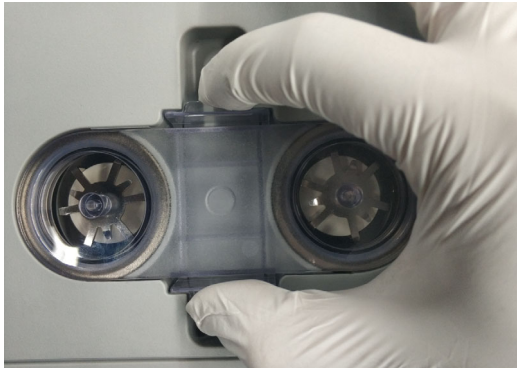

Figure 9-15 Remove the valve dome

2. Lift the inspiration and expiration valves from the breathing system body.



Figure 9-16 Remove the inspiration and expiration valves

9.7.3.1.10 Volume Exchanger

1. As shown in the figure, pull the unlocking button outward.



Figure 9-17 Open the volume exchanger cover

2. Put out the volume exchanger following the screen-printed instructions.

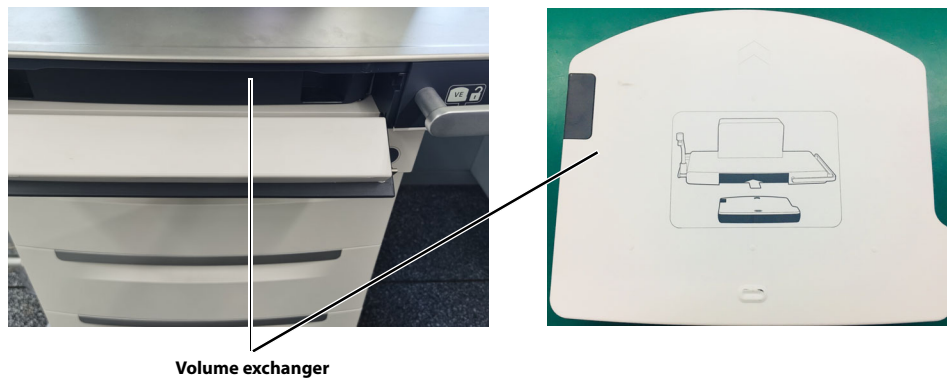

Figure 9-18 Put out the volume exchanger

3. Close the volume exchanger cover.

9.7.3.1.11 Visual Inspection

After the disassembly, inspect the following components for damage, wear and tear, and the visual inspection criteria is no damage, no creak, no distortion.

- Volume Exchanger
- Breathing System Body
- Bag Arm
- O₂ sensor support
- Bypass
- CO₂ Absorbent Canister
- Inspiration connector
- Expiration connector
- Flow sensors
- Inspiration valve
- Expiration valve
- Seals and sealing rings

If the components are damaged, worn and torn, contact your service personnel or Mindray.

9.7.3.2 Cleaning and Disinfection (Choose One)

9.7.3.2.1 Manual Cleaning

1. Submerge or rinse the Breathing System in an authorized cleaning agent (See Table 9-3 "Manual Cleaning Agent" on Pages 9-9) for the required period as specified by the manufacturer of the cleaning solution.
2. Rinse the Breathing System with the clean water.
3. Completely dry the Breathing System before use.
4. To disinfect the Breathing System, proceed to following steps. Otherwise, jump to 9.7.3.4 Reassembly.

9.7.3.2.2 Automated Cleaning and Disinfection

NOTE: Use a washer-disinfector that meets the requirements of the standard ISO 15883.

NOTE: Use cleaning adaptor kit (see the accompanying document) for automated cleaning and disinfection.

NOTE: Except O₂ sensors and airway pressure gauge, all the components of the breathing system are resistant to automated cleaning and disinfection.

NOTE: At least 250 reprocessing cycles are possible for the breathing system.

1. Pre-wash with water.
2. Cleaning using cleaning agent (See Table 9-5 "Automated Cleaning Agent" on Pages 9-10) in accordance with the manufacturer's instructions for use.
3. Rinse with water.
4. Thermal disinfection at a temperature of 90°C (194 °F) for 5 minutes (recommended disinfection condition).
5. Repeat the cycle if necessary.
6. Allow the Breathing System to cool and dry completely before use.

9.7.3.3 Autoclaving (Additional Reprocessing)

NOTE: Before the disinfection, make sure that the assembly has been cleaned following 9.7.3.2.1 Manual Cleaning.

CAUTION: Ensure that the connectors of the volume exchanger is directed toward the water during the autoclaving.

1. To disinfect the Breathing System, use an authorized autoclaving process (See Table 9-6 "Autoclaving process" on Pages 9-10) to autoclave at a maximum temperature of 134°C (273 °F) for 20 minutes (recommended disinfection time).
2. Allow the Breathing System to cool and dry completely before use.

9.7.3.4 Reassembly

NOTE: Before the reassembly, make sure that the assembly has been reprocessed and dried.

NOTE: Reassemble the breathing System at the point of use and at the designated cleaning area.

Before the reassembly, inspect the following components for damage, wear and tear, and the visual inspection criteria is no damage, no creak, no distortion.

- Volume Exchanger
- Breathing System Body
- Bag Arm
- O₂ sensor support
- Bypass
- CO₂ Absorbent Canister
- Inspiration connector
- Expiration connector
- Flow sensors
- Inspiration valve
- Expiration valve
- Seals and sealing rings

If the components are damaged, worn and torn, contact your service personnel or Mindray.

9.7.3.4.1 Volume Exchanger

1. As shown in the figure, pull the unlocking button outward.



Figure 9-19 Open the volume exchanger cover

2. Put in the volume exchanger following the screen-printed instructions.

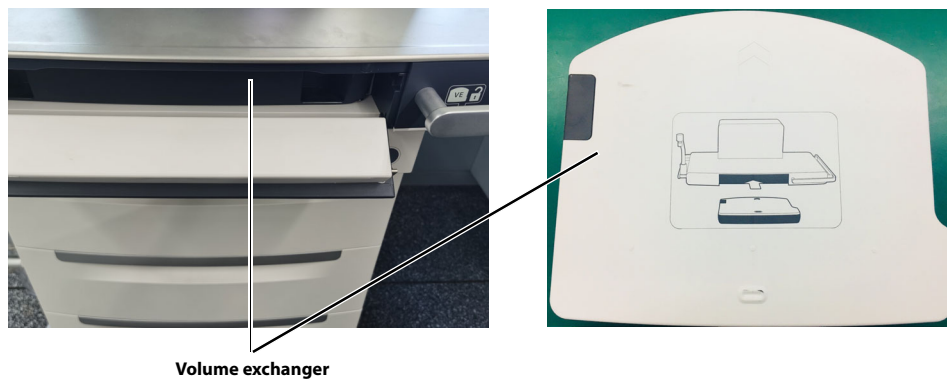

Figure 9-20 Put in the volume exchanger

3. Close the volume exchanger cover.

9.7.3.4.2 Inspiration and Expiration Valves

1. Insert the inspiration and expiration valves into the breathing system body.



Figure 9-21 Insert the inspiration and expiration valves

2. Install the valve dome to the breathing system body. You will hear a snap when the valve dome is installed in place.

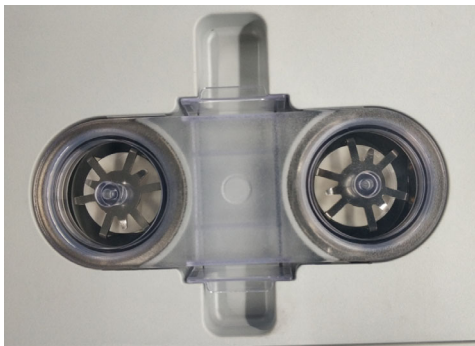

Figure 9-22 Install the valve dome

9.7.3.4.3 Breathing System Body

Hold the handrails on one side of the breathing system body and push the breathing system body into the anesthesia system. Make sure that the two surfaces in the following figure are in the same plane and hear a snap.



Make sure both of the surfaces are in the same plane and hear a snap.

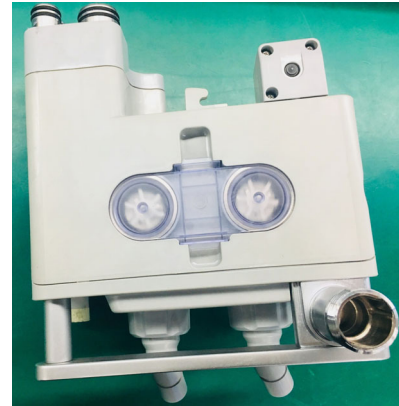

Figure 9-23 Install the breathing system body

9.7.3.4.4 Bag Arm

To install the bag arm, align it with the slot on the breathing system and screw the retaining ring clockwise until it is tightened.

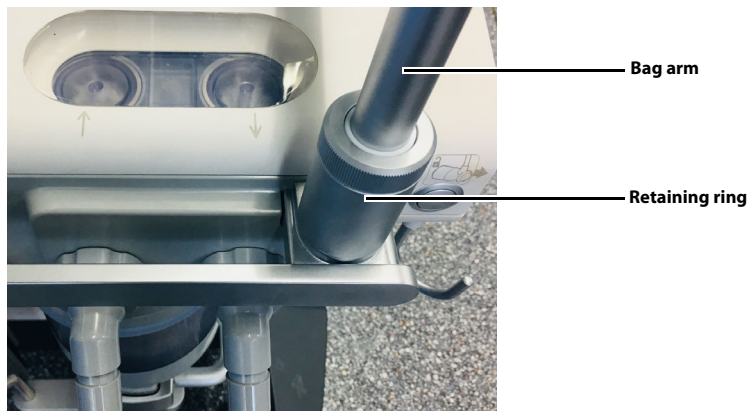

Figure 9-24 Install the bag arm

9.7.3.4.5 Flow Sensor

WARNING: Tighten the locking nut of the screw cap at the inspiration/expiration connector when installing the flow sensor. Otherwise it may cause a failure of the flow sensor.

WARNING: Exercise caution when moving the anesthesia system to avoid damage to the flow sensor because of collision at the inspiration/expiration connector.

WARNING: Keep the breathing tube end that is connected to the inspiration/expiration connector heading downward. Otherwise the water formed by condensed vapor may flow into the inspiration/expiration connector and affect measurement of the flow sensor.

1. Insert the flow sensor in the direction shown in the figure and keep the side with the screen printing upward.



Figure 9-25 Install the flow sensor

2. Insert the flow sensor horizontally to the end.
3. Align the inspiration/expiration connector with the flow sensor slot, and tighten up the locking nut clockwise.

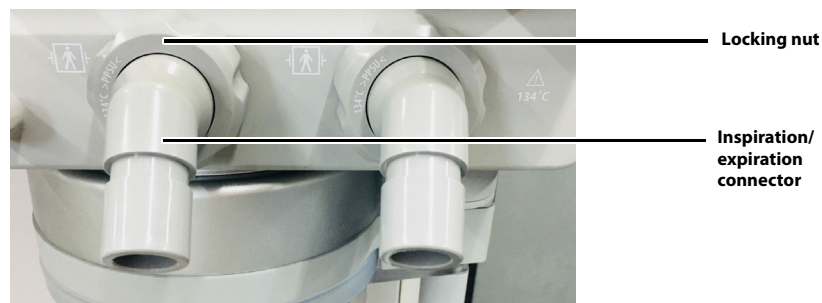

Figure 9-26 Install the inspiration/expiration connector and locking nut

9.7.3.4.6 Bypass

Press and hold the buckle button on the bypass assembly, align the bypass assembly with the bypass installing plate and push the assembly upward into position to install the bypass. You will hear a snap when the bypass is installed in place.

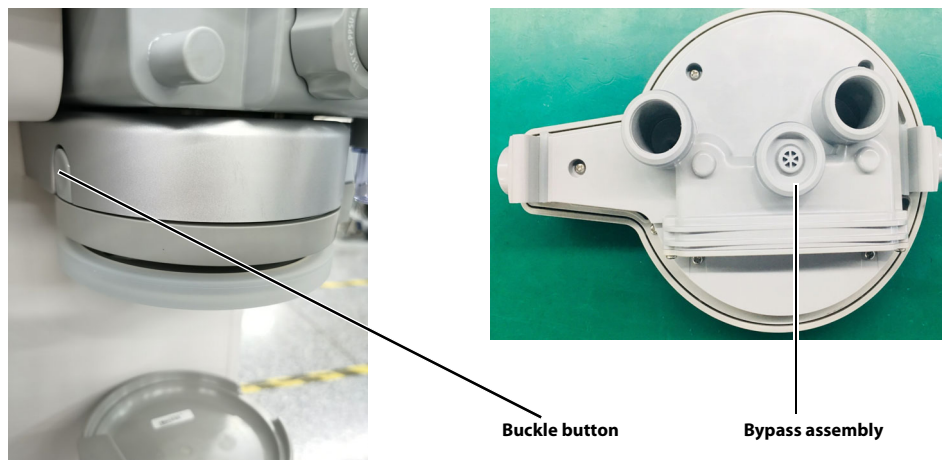

Figure 9-27 Install bypass

NOTE: When the bypass is enabled, gases in the breathing system do not go through the CO₂ absorbent canister.

9.7.3.4.7 CO₂ Absorbent Canister

Load absorbent into the canister and place the canister onto the underpan assembly. Rotate the handle counter clockwise to the horizontal position to lock the canister.



Unlocking position.
The bypass is turned on.

Gasket

Figure 9-28 Canister unlocking



Locking position.
The bypass is turned off.

Gasket

Figure 9-29 Canister locking

WARNING: Use extreme care while handling the CO₂ absorbent as it is a caustic irritant.

WARNING: Check if the gasket is properly installed in place while installing the canister. If the gasket is not properly installed, it may cause breathing system leaks.

WARNING: Before locking the canister, make sure that the gasket on the bypass assembly has no residual absorbent particles or powder. Otherwise it may cause breathing system leaks.

NOTE: Before adding the absorbent, make sure that the canister is fully dry.

NOTE: The absorbent poured in should not surpass the Max mark on the CO₂ absorbent canister.

9.7.3.4.8 O₂ Sensor

1. Press the O₂ sensor cover switch to open the O₂ sensor cover.

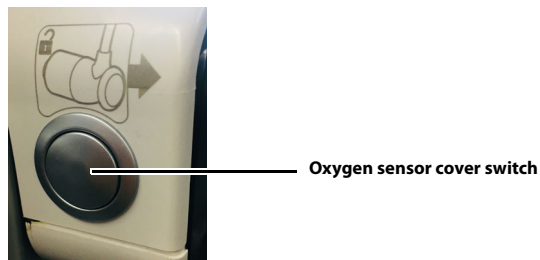

Figure 9-30 Open the O₂ sensor cover

2. Rotate the O₂ sensor clockwise to install it to the support.

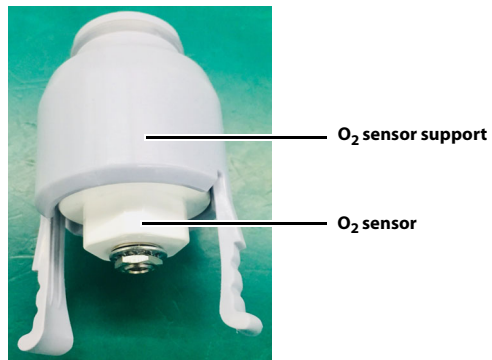

Figure 9-31 Install the O₂ sensor to the support

3. Insert the O₂ sensor support to the breathing system.



Figure 9-32 Insert the O₂ sensor support to the breathing system

4. Insert the O₂ sensor cable.

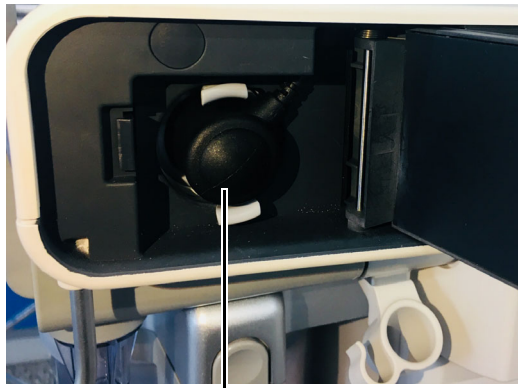

Oxygen sensor cable

Figure 9-33 Insert the O₂ sensor cable

5. Close the O₂ sensor cover. The O₂ sensor is now fully installed.

9.7.3.4.9 Manual bag

Directly insert or draw out the manual bag to install or disassemble it.



Manual bag

Figure 9-34 Install the manual bag

9.7.3.4.10 Breathing Tube

- NOTE:** When installing a breathing tube, hold the joints at both ends of the tube to prevent damage to the tube.
- NOTE:** Do not reuse the bacteria filter repeatedly to prevent cross infection.
- NOTE:** Install the filter following the instructions in this manual to prevent dust or particles from entering the patient's lungs and prevent cross infection.
- CAUTION:** The bacteria filter shall comply with the requirements of ISO 23328-1 and ISO 23328-2.

1. Install the expiratory tube and inspiratory tube to the expiration connector and the inspiration connector of the breathing system, respectively.

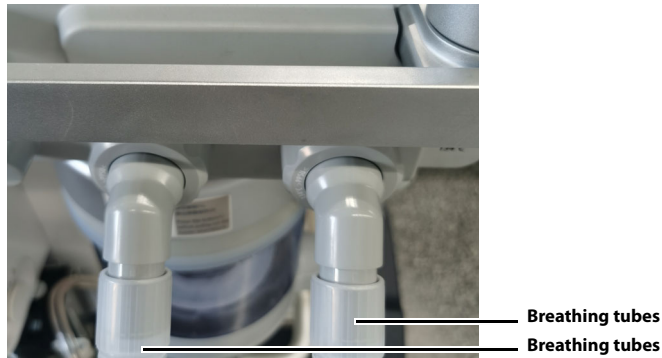

Figure 9-35 Install the breathing tubes

2. Install the bacteria filter onto the Y-piece.

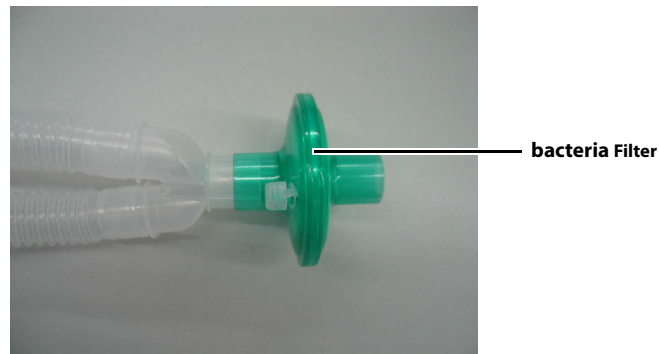

Figure 9-36 Install the bacteria filter

9.7.3.5 Check Before the Next Use

After reassemble the components of the breathing system, power on the Anesthesia System and follow the on-screen prompts to perform leak test and compliance test. See Section 5.4.2 "Leak & Compliance Test".

9.7.4 Negative Pressure Suction Device

9.7.4.1 Disassembly

NOTE: **Disassemble the Negative Pressure Suction Device at the point of use or at the designated cleaning area.**

To disassemble the negative pressure suction device, pull out the suction tube and discard the filter.

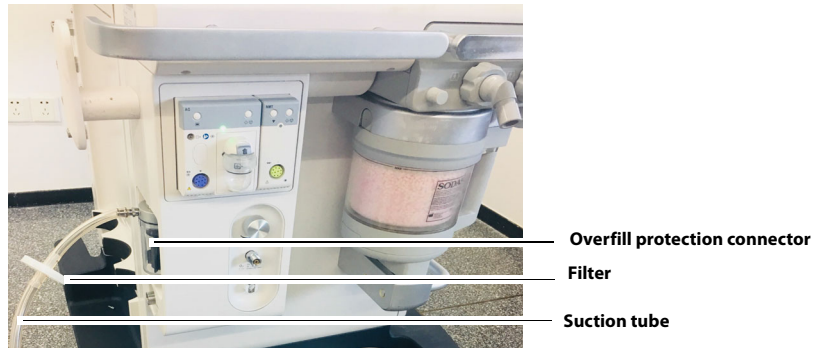

Figure 9-37 Disassemble the negative pressure suction device

NOTE: **Filters are disposable accessories. Please follow local regulations to dispose of discarded filters.**

9.7.4.2 Cleaning

1. Submerge or rinse the suction tube in an authorized cleaning agents (See Table 9-3 "Manual Cleaning Agent" on Pages 9-9) for the required period as specified by the manufacturer of the cleaning solution.
2. Rinse the suction tube with the clean water.
3. Completely dry the suction tube before use.
4. To disinfect the suction tube, proceed to 9.7.4.3 **Disinfection**. Otherwise, jump to 9.7.4.4 Reassembly.

9.7.4.3 Disinfection

NOTE: **Before the disinfection, make sure that the suction tube has been cleaned following 9.7.4.2 Cleaning.**

1. Submerge or rinse the suction tube in an authorized disinfectors (See Table 9-4 "Manual Disinfectant" on Pages 9-10) for the required period as specified by the manufacturer of the disinfecting solution.
2. Rinse the suction tube with the clean water.
3. Completely dry the suction tube before use.

9.7.4.4 Reassembly

NOTE: **Before the reassembly, make sure that the assembly has been reprocessed and dried.**

NOTE: **Reassemble the Negative Pressure Suction Device at the point of use and at the designated cleaning area.**

1. Place the liquid collection bottle to the bracket. Connect the suction tube and the filter following the screen printed instructions.
2. Insert the suction tube to the overfill protection connector. The negative pressure suction device is now fully installed.

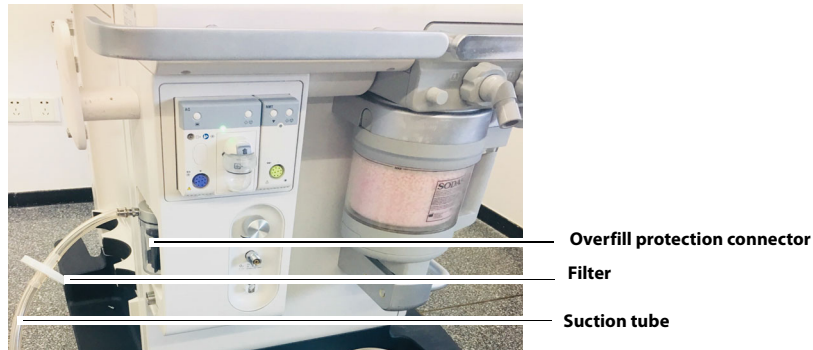

Figure 9-38 Install the negative pressure suction device

NOTE: When install the filter to the suction tube, pay attention to keeping the side printed with IN facing the liquid collection bottle.

NOTE: Avoid twisting or bending suction tubes during use.

9.7.4.5 Check Before the Next Use

After reassemble the components of the negative pressure suction device, check the negative pressure suction device before use. See Section 5.14 "Inspect the Negative Pressure Suction Device".

9.8 Periodic Maintenance

WARNING: To avoid endangering the patient, do not perform test or maintenance when the equipment is in use.

Visual inspection should be performed every 30 days to ensure timely replacement of worn or damaged parts.

1. Power off the system.
2. Visually check the whole system.
3. Power on the system and follow the on-screen prompts to perform leak test and compliance test. See Section 5.4.2 "Leak & Compliance Test".

This page intentionally left blank.

Product Specifications

Standards Compliance	10-2
Safety Designations.....	10-4
Physical Specifications.....	10-4
Environmental Specifications.....	10-6
Environmental Specifications.....	10-6
Electrical Specifications.....	10-6
Pneumatic Specifications.....	10-8
Breathing System Specifications.....	10-10
Anesthetic Gas Scavenging System (AGSS)	10-14
Negative Pressure Suction device	10-14
Monitor Module.....	10-15
Ventilator Specifications	10-21
Displays and Controls Specifications.....	10-24
Alarms	10-25
Response Time of the Anesthesia System to an Increase in O2 Concentration (From 21% to 90%/100%).....	10-26

10.1 Standards Compliance

The Anesthesia System is in compliance with the following industry standards.

ANSI/AAMI ES60601-1:2005/(R)2012 and A1:2012, C1:2009/(R)2012 and A2:2010/(R)2012	Medical electrical equipment - Part 1: General requirements for basic safety and essential performance
IEC 60601-1-2:2014/A1:2020	Medical electrical equipment - Part 1-2: General requirements for basic safety and essential performance - Collateral Standard: Electromagnetic disturbances - Requirements and tests
IEC 60601-1-6 Edition 3.1 2013-10	Medical electrical equipment - Part 1-6: General requirements for basic safety and essential performance - Collateral standard: Usability
IEC 60601-1-8 Edition 2.1 2012-11	Medical electrical equipment - Part 1-8: General requirements for basic safety and essential performance - Collateral standard: General requirements, tests and guidance for alarm systems in medical electrical equipment and medical electrical systems
IEC 62304 Edition 1.1 2015-06	Medical device software - Software life cycle processes
IEC 62366-1 Edition 1.0 2015-02	Medical devices - Part 1: Application of usability engineering to medical devices
ISO 10993-1 Fifth edition 2018-08	Biological Evaluation of Medical Devices - Part 1: Evaluation and testing within a risk management process
ISO 10993-5 Third edition 2009-06-01	Biological Evaluation of Medical Devices -- Part 5: Tests for in vitro cytotoxicity
ISO 10993-10 Third edition 2010-08-01	Biological Evaluation Of Medical Devices -- Part 10: Tests for irritation and skin sensitization
ISO 10993-18 First edition 2005-07-01	Biological evaluation of medical devices -- Part 18: Chemical characterization of materials
ISO 14971 Second edition 2007-03-01	Medical Devices - Application of Risk Management to Medical Devices
ISO 15223-1 Third edition 2016-11-01	Medical Devices - Symbols to be used with Medical Device Labels, labeling and Information to be supplied - Part 1: General Requirements
ISO 80601-2-13 First edition 2011-08-01	Medical electrical equipment - Part 2-13: Particular requirements for basic safety and essential performance of an anaesthetic workstation [including: Amendment 1 2015-03-01 and Amendment 2 2018-07]
ISO 80601-2-55 Second edition 2018-02	Medical electrical equipment - Part 2-55: Particular requirements for the basic safety and essential performance of respiratory gas monitors
ISO 5356-1 Fourth edition 2015-03-15	Anaesthetic and respiratory equipment - Conical connectors - Part 1: cones and sockets
CGA V-1:2013	Standard for Compressed Gas Cylinder Valves Outlet and Inlet Connections
CGA V-5:2008 (Reaffirmed 2013)	Diameter index safety system (Noninterchangeable low pressure connections for medical gas applications)
ASTM F1101-90 (Reapproved 2003)	Standard Specification for Ventilators Intended for Use During Anesthesia
ISO 10993-12 Fourth edition 2012-07-01	Biological evaluation of medical devices - Part 12: Sample preparation and reference materials

TABLE 10-1 Standards Compliance

ISO 10079-3 Third edition 2014-05-01	Medical suction equipment - Part 3: Suction equipment powered from a vacuum or pressure source
ISO 18562-1 First edition 2017-03	Biocompatibility evaluation of breathing gas pathways in healthcare applications - Part 1: Evaluation and testing within a risk management process
ISO 18562-2 First edition 2017-03	Biocompatibility evaluation of breathing gas pathways in healthcare applications - Part 2: Tests for emissions of particulate matter
ISO 18562-3 First edition 2017-03	Biocompatibility evaluation of breathing gas pathways in healthcare applications - Part 3: Tests for emissions of volatile organic compounds (VOCs)
ISO 17664 Second edition 2017-10	Processing of health care products - Information to be provided by the medical device manufacturer for the processing of medical devices
ISO 5360 Fourth edition 2016-02-15	Anaesthetic vaporizers - Agent-specific filling systems

TABLE 10-1 (Continued) Standards Compliance

The anesthesia system shall be used together with the monitoring devices, alarm system and protective devices below:

- The pressure measurement device in compliance with ISO 80601-2-13;
- The pressure restriction device in compliance with ISO 80601-2-13;
- The expiratory volume monitor in compliance with ISO 80601-2-13;
- The breathing system with alarm system in compliance with ISO 80601-2-13;
- The anaesthetic vapour delivery system in compliance with ISO 80601-2-13;
- The anaesthetic gas scavenging system in compliance with ISO 80601-2-13;
- The anesthetic gas delivery device in compliance with ISO 80601-2-13;
- The anesthetic ventilator in compliance with ISO 80601-2-13;
- The O₂ monitor in compliance with ISO 80601-2-55;
- The CO₂ monitor in compliance with ISO 80601-2-55;
- The AG monitor in compliance with ISO 80601-2-55.

The anesthesia system is integrated with the pressure measurement device, pressure restriction device, expiratory volume monitor, anaesthetic breathing system with alarm system, anaesthetic gas delivery system, anaesthetic vapour delivery system, anaesthetic ventilator, AG monitor in compliance with the afore mentioned standards, where:

- The pressure restriction device, expiratory volume monitor and breathing system with alarm system also comply with ISO 80601-2-13.
- AG monitor in compliance with ISO 80601-2-55.

10.2 Safety Designations

Type of Protection against Electric Shock:	Class I equipment with internal electric power supply. Where the integrity of the external protective earth (ground) in the installation or its conductors is in doubt, the equipment shall be operated from its internal electric power supply (i.e., battery supply).
Degree of Protection against Electric Shock:	Type BF, defibrillation-proof
Rated voltage and frequency of equipment:	External electric power supply: AC: 100V to 120 V, 50/60 Hz Internal Battery: 12V 24Ah (two pieces)
Input power of equipment:	100V to 120V, 10A
Mode of Operation:	Continuous
Degree of Protection against Hazards of Explosion:	Not for use with flammable anesthetics.
Degree of Protection against Harmful Ingress of Water:	IPX1
Electrical Connection between Equipment and Patient:	Electrical connections
Degree of Mobility:	Mobile (including the base and casters)
Disinfection methods:	Steam autoclavable or disinfectable
Application parts with protection against electric shock:	All application parts
Signal input or output part:	Both signal input and output parts
Permanent or non-permanent installation:	Non-permanent installation

TABLE 10-2 Safety Designations

10.3 Physical Specifications

Dimensions:	Height: 1490 mm (59 in) Width: 910 mm (36 in) Depth: 705 mm (28 in)
Weight:	≤160 kg (353 lbs)(Standard configured mass) ≤290 kg (639 lbs)(Maximum configured mass)
Worktable (stainless steel):	Weight limit: 30kg (66 lbs) Width: 590 mm (23 in) Depth: 325 mm (13 in) Height: 850 mm (33 in)
External Auxiliary Worktable:	Weight limit: 15 kg (33 lbs) Width: 480 mm (19 in) Depth: 310 mm (12 in)

TABLE 10-3 Physical Specifications

Top Shelf:	Weight limit: 15 kg (33 lbs) Width: 480 mm (19 in) Depth: 310 mm (12 in)
Side Mounting Rails:	Supporting weight: 27 kg (60 lbs) from a GCX-compatible rail at a maximum distance of 0.41m with a safety factor of 6 times the weight
Bag Arm:	Fixed Height Bag Arm: Length: 312 mm (12 in) Height: 1130 mm (44 in) Swiveling angle: ± 120 degrees Flexible Bag Arm: Length: 550mm (22 in) Flexible bag arm shall be adjusted the height and the angle freely.
Drawers (internal dimensions):	Weight limit: 5 kg (11 lbs) Drawers are of equal size: • Height: 140 mm (6 in) • Width: 420 mm (17 in) • Depth: 315 mm (12 in)
Caster:	4 casters Diameter: 125 mm (5 in) Brake: central brake system with lock/unlock indicator Cable pusher: cable pusher with each caster
System Noise (under the typical working mode):	≤ 50 dB(A)

TABLE 10-3 Physical Specifications

10.4 Environmental Specifications

Operating Temperature:	+10°C to +40°C (V90 Desflurane Electronic Vaporizer: 10°C to 35°C) +50°F to 104°F (V90 Desflurane Electronic Vaporizer: 50°F to 95°F)
Storage Temperature:	-20°C to +60°C (Oxygen Cell: -20°C to 50°C) -4°F to 140°F (Oxygen Cell: -4°F to 122°F)
Operating Humidity:	15 to 95% RH, non-condensing
Storage Humidity:	10 to 95% RH, non-condensing
Operating Atmospheric Pressure:	70 kPa to 106.7 kPa (10 psi to 15.5 psi)
Storage Atmospheric Pressure:	50 kPa to 106.7 kPa (7.3 psi to 15.5 psi)

TABLE 10-4 Environmental Specifications

10.5 Electrical Specifications

10.5.1 Main Electrical Power Specifications

The anesthesia system complies with ANSI/AAMI ES60601-1 for its main power supply.

Power Supply Input Voltage:	100 to 120 VAC @ 50/60 Hz
Power Supply Input Current:	10 A maximum (5 A maximum for anesthesia system, 5A maximum for auxiliary outlets)
Length of Power Cord:	5 m
Grade of Power Cord:	Hospital grade

TABLE 10-5 Main Electrical Power Specifications

10.5.2 Battery Power Specifications

Battery Type:	Sealed lead acid battery, Two (2) batteries: 12VDC, 24Ah
Battery Run-time:	<p>≥90 minutes (powered by new fully-charged battery under the typical condition) ≥ 50 minutes (powered by new fully-charged battery under the worst power consumption condition)</p> <p>Typical condition:</p> <ul style="list-style-type: none"> • VCV mode: Vt = 500 ml, RR = 10 bpm, I:E = 1:2, Plimit = 40 cmH₂O, PEEP = 0 cmH₂O, Tpause = OFF • Electronic Flowmeter is in working condition (Total flow: 2.0L/min; O₂%: 50%) • Screen brightness: Default Value • Alarm volume: Default Value • Key tip tone: Default Value • Dome light: OFF • Sampling rate of Anesthetic Gas Monitoring Module: 150mL/min • Electronic Vaporizer is in working condition (DES: 10.0%; ISO: 1.0%; SEV: 1.0%) • Auxiliary Flowmeter is in working condition (Total flow: 2.0L/min; O₂%: 50%) • Active Electronic AGSS is in working condition • Gas Supply Rated Working Pressure: 400kPa±100kPa • Resistance: 20cmH₂O/L/s • Compliance: 20mL/cmH₂O <p>Worst power consumption condition:</p> <ul style="list-style-type: none"> • VCV mode: Vt = 2000 ml, RR = 30bpm, I:E = 4:1, Plimit = 100 cmH₂O, PEEP = 50 cmH₂O, Tpause = OFF • Electronic Flowmeter is in working condition (Total flow: 18.0L/min; O₂%: 50%) • Screen brightness: Brightest • Alarm volume: Highest • Key tip tone: Highest • Dome light: High • Sampling rate of Anesthetic Gas Monitoring Module: 200mL/min • Electronic Vaporizer is in working condition (DES: 18.0%; ISO: 5.0%; SEV: 8.0%) • Auxiliary Flowmeter is in working condition (Total flow: 15.0L/min; O₂%: 50%) • Active Electronic AGSS is in working condition • Gas Supply Rated Working Pressure: 400kPa±100kPa • Resistance: 20cmH₂O/L/s • Compliance: 20mL/cmH₂O
Time to Shutdown from Lower Battery Alarm:	5 minutes at least (powered by new fully-charged batteries after the first low-power alarm)
Battery Charge Time:	New Battery: < 12 hours (powered by new depleted batteries at 25°C ambient temperature under typical working mode).

TABLE 10-6 Battery Power Specifications

10.5.3 Auxiliary Electrical Outlets

Number of Outlets:	4
Output Voltage:	Corresponds to power supply input voltage
Output Current of Each Auxiliary Outlet:	3 A max.
Output Current for Total Auxiliary Outlet:	5 A max.
Breaker Rating Current of Each Auxiliary Outlet:	3 A
Breaker Rating Current for Total Auxiliary Outlet:	5 A

TABLE 10-7 Auxiliary Electrical Outlets

10.5.4 Communication Ports

RS-232 Communication Port:	One DB9 male connector. Provides a non-isolated output serial RS232C interface. It is used for connection of calibration equipment by a Mindray-authorized service representative.
	NOTE: Do not connect any non-isolated devices to the DB9/RS232C interface of the Anesthesia System.
Network Port:	Two separate RJ-45 network ports
SB Ports:	Four SB ports
	CAUTION: Do not connect any devices to the SB ports other than Mindray approved USB storage devices and a supported USB mouse.
Video Signal Port:	One DB15 female port for outputting the video signal of the main display to external display.

TABLE 10-8 Communication Ports

10.6 Pneumatic Specifications

10.6.1 Pipeline Supply

Pipeline Input Pressure Range:	O ₂ : 280 to 600 kPa (40 to 87 psi) N ₂ O: 280 to 600 kPa (40 to 87 psi) Air: 280 to 600 kPa (40 to 87 psi)
Pipeline Input Flow Rate Range:	O ₂ : V'max. 190 L/min Air: V'max. 70 L/min N ₂ O: V'max. 20 L/min
Pipeline Connections:	DISS body complying with CGA V-5
Gas Configuration:	N ₂ O, Air, O ₂

TABLE 10-9 Pipeline Supply

10.6.2 Cylinder Supply

Cylinder Supply:	E-cylinder (American style) and pin indexed per CGA V-1
O₂ Cylinder Input Pressure Range:	6.9 to 20.0 MPa (1000 to 2900 psi)
N₂O Cylinder Input Pressure Range:	4.2 to 6.0 MPa (600 to 870 psi)
Air Cylinder Input Pressure Range:	6.9 to 20.0 MPa (1000 to 2900 psi)
Cylinder Input Flow Rate Range:	O ₂ : V'max. 190L/min Air: V'max. 70L/min N ₂ O: V'max. 20 L/min
Cylinder Connections:	Pin-Index Safety System (PISS)
Yoke Configuration:	O ₂ , Air, N ₂ O

TABLE 10-10 Cylinder Supply

10.6.3 Auxiliary Common Gas Outlet (ACGO)

Control type	Mechanical
Connector:	Coaxial 22mm male/15mm female conical connector complying with ISO 5356-1
Safety Pressure:	A pressure relief valve limits fresh gas pressure at the ACGO outlet port to not more than 12.5 kPa.
Fresh Gas Flow:	0.00 to 20.0 L/min

TABLE 10-11 ACGO

10.6.4 Anesthetic Vaporizer

Type:	Electronic injection	
Applicable Anesthetic Agent:	Isoflurane, Sevoflurane, Desflurane	
Filling Method:	Safety Filling Adapter:	Isoflurane vaporizer, Sevoflurane vaporizer
	Quik-Fil:	Sevoflurane vaporizer
	Saf-T-Fill:	Desflurane vaporizer
Dimension:	Height: 215 mm Width: 75 mm Depth: 185 mm	
Weight:	3.5 kg (7.7 lb) (Empty) 4.0 kg (8.8 lb) (Full)	
Vaporizer Volume:	320 mL	
Volume (Between the minimum and maximum marks):	280 mL	
Leakage of Anaesthetic Vaporizer Position and the Mixing Chamber Branch of Electronic Vaporizer:	≤5mL/min@50kPa	
Leakage of Anaesthetic Vaporizer Position and the Driven Gas Branch of Electronic Vaporizer:	≤5mL/min@150kPa	
Anesthetic Agents Loss (24 hours in storage):	<1.0mL	

TABLE 10-12 Anesthetic Vaporizer

Concentration Setting Range:	Isoflurane: 0.0 vol.% to 5.0 vol.% Sevoflurane: 0.0 vol.% to 8.0 vol.% Desflurane:0.0 vol.% to 18.0 vol.%
Concentration Output Accuracy:	±15% of the setting value or ±5% of the maximum setting value, whichever is greater

TABLE 10-12 Anesthetic Vaporizer

10.6.5 Drive Gas

O₂

10.6.6 O₂ Controls

O₂ supply failure alarm: ≤220.6kPa±34.2kPa

10.7 Breathing System Specifications

10.7.1 Breathing System Volume

Mechanical Ventilation:	Approx. 1800mL (Including CO ₂ absorbent, not including volume exchanger)
Manual Ventilation:	Approx. 1950mL (Including CO ₂ absorbent and bag arm, not including manual bag)

TABLE 10-13 Breathing System Volume

10.7.2 Volume Exchanger Volume

Volume:	1500mL
----------------	--------

TABLE 10-14 Volume Exchanger Volume

10.7.3 CO₂ Absorber Assembly

Absorber Capacity:	1 Pre-Pak (1500ml)
Absorber Canister Contents:	1 Pre-Pak canister or Loose Fill absorbent

TABLE 10-15 CO₂ Absorber Assembly

10.7.4 Breathing System Connections

Exhalation Connection:	Coaxial 22mm male/15mm female conical connector complying with ISO 5356-1
Inhalation Connection:	Coaxial 22mm male/15mm female conical connector complying with ISO 5356-1
Manual bag connection:	Coaxial 22mm male/15mm female conical connector complying with ISO 5356-1
Exhaust port:	30mm male conical connector complying with ISO 5356-1

TABLE 10-16 Breathing System Connections

10.7.5 APL Valve

Range:	SP, 5 to 70 cmH ₂ O
Control accuracy	± 3 cmH ₂ O or ±15% of the setting value, whichever is greater, but is not more than +10 cmH ₂ O
Adjustable Range of Motion:	> 300 degrees
Tactile Knob Indication:	30 cmH ₂ O and above
Opening pressure :	≤ 2.0cmH ₂ O (test gas in dry or wet conditions)

Resistance of APL valve in dry gas:

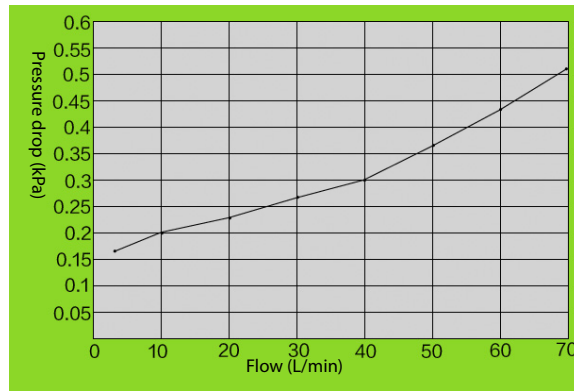

Resistance of APL valve in wet gas:

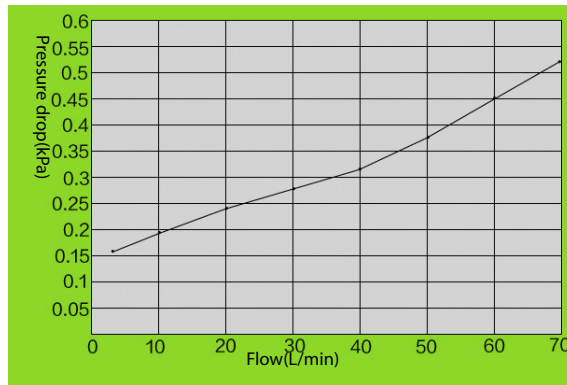
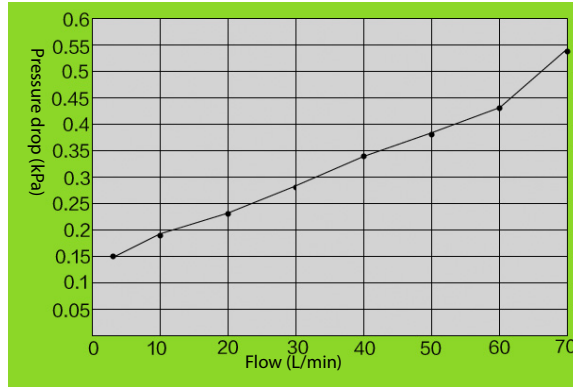

TABLE 10-17 APL Valve

Resistance of APL valve in dry gas (Lift the APL Valve):



Resistance of APL valve in wet gas (Lift the APL Valve):

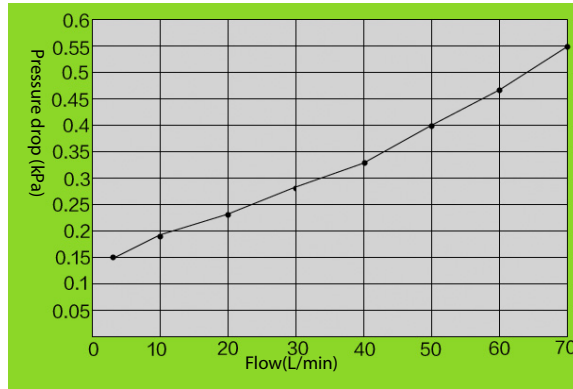

TABLE 10-17 APL Valve

10.7.6 Resistance

Expiratory resistance in mechanical ventilation mode:

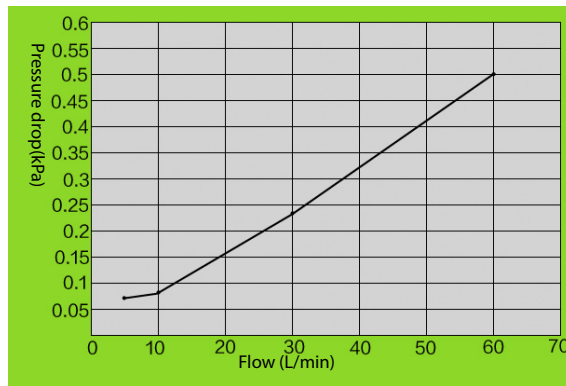
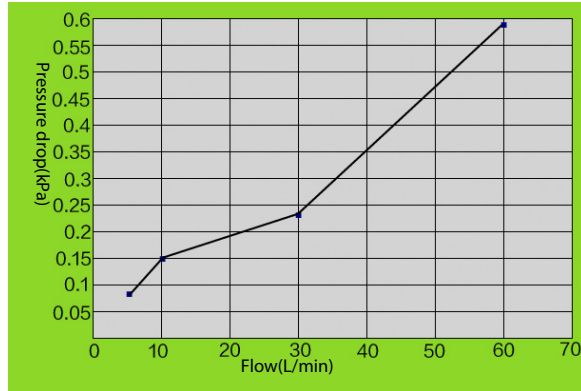
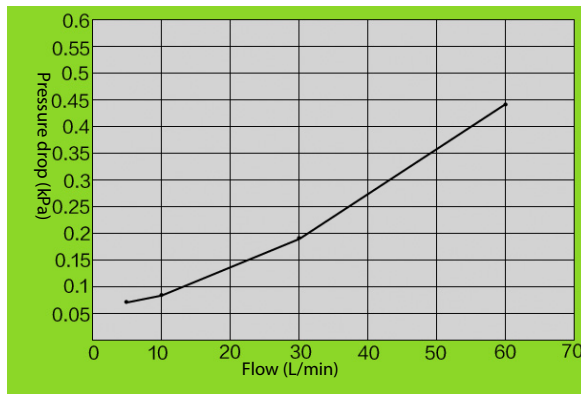

TABLE 10-18 Resistance

Inspiratory resistance in mechanical ventilation mode:



Expiratory resistance in manual mode:



Inspiratory resistance in manual mode:

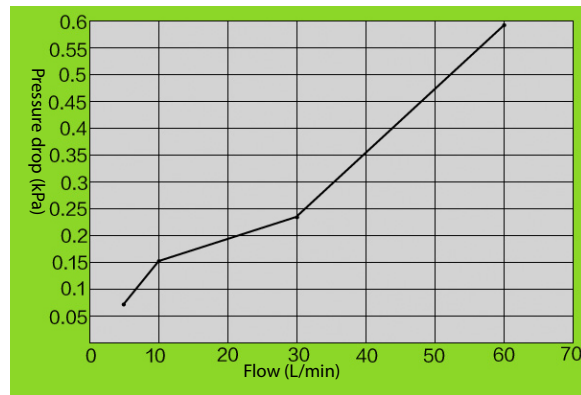

TABLE 10-18 Resistance

10.7.7 Breathing System Temperature Controller

$10^{\circ}\text{C} \leq T(\text{Ambient temperature}) \leq 20^{\circ}\text{C}$:	$\Delta T = T$ (Temperature at metal test point of the pressure sampling body near the inspiratory check valve) - T (Ambient temperature) $\geq 11^{\circ}\text{C}$
$20^{\circ}\text{C} \leq T(\text{Ambient temperature}) \leq 40^{\circ}\text{C}$	T (Temperature at metal test point of the pressure sampling body near the inspiratory check valve) $\geq 31^{\circ}\text{C}$
$10^{\circ}\text{C} \leq T(\text{Ambient temperature}) \leq 40^{\circ}\text{C}$	$\Delta T = T$ (Temperature at test point of Y-piece patient connection) - T (Ambient temperature) $\leq 2^{\circ}\text{C}$ and T (Temperature at test point of Y-piece patient connection) $\leq 41^{\circ}\text{C}$
Single fault condition	T (Temperature at test point of Y-piece patient connection) $\leq 41^{\circ}\text{C}$

Note: The block heater does not operate while the system is being powered by the internal battery supply.

TABLE 10-19 Breathing System Temperature Controller

10.7.8 Breathing Circuit Parameters

System Compliance:	≤ 2 ml/cm H_2O
Resistance:	≤ 6 cm H_2O
Leakage:	≤ 50 ml/min @ 3 kPa (under BTPS condition)
System Safety Pressure on Breathing System:	110 cm H_2O

TABLE 10-20 Breathing Circuit Parameters

10.7.9 Unidirectional Valve Opening Pressure

Dry: ≤ 0.12 kPa opening pressure.

Wet: ≤ 0.12 kPa opening pressure.

10.8 Anesthetic Gas Scavenging System (AGSS)

Type of the Applicable Disposable System:	Low flow
Extract Flow:	25 to 50 L/min
Resistance:	≤ 0.05 kPa @ 25 L/min ≤ 0.05 kPa @ 30 L/min ≤ 0.35 kPa @ 50 L/min ≤ 0.35 kPa @ 75 L/min

TABLE 10-21 Anesthetic Gas Scavenging System (AGSS)

10.9 Negative Pressure Suction device

Performance Category:	Pharyngeal Suction
Gas Supply:	External vacuum system
Gas Supply Pressure Range:	-72 kPa to -40 kPa

TABLE 10-22 Suction device

Flow Input Range:	20 L/min to 40 L/min
Maximum Vacuum:	69 kPa to 72 kPa (517.5 mmHg to 540 mmHg) with external vacuum applied of 72 kPa (540 mmHg) and 40 L/min free flow
Maximum Flow:	39 L/min to 40 L/min with external vacuum applied of 72 kPa (540 mmHg) and 40 L/min free flow
Minimum Flow:	20 L/min
Vacuum Gauge Accuracy:	± 5 % of full scale

TABLE 10-22 Suction device

10.10 Monitor Module

10.10.1 AG Module

Warm-up time:	ISO accuracy mode: < 45 s Full accuracy mode: <10 min
Sampling rate:	Sampling rate: Adult/Pediatric AG watertrap and sample line: 150/180/200 ml/min Neonate AG watertrap and sample line: 100/110/120 ml/min Accuracy: ± 10 ml/min or ± 10 % of the setting value, whichever is greater
Watertrap emptying interval¹	Adult/Pediatric AG watertrap: ≥19h@150ml/min ≥18h@180ml/min ≥17h@200ml/min Neonate AG watertrap: ≥24h@100ml/min ² ≥22h@110ml/min ≥20h@120ml/min
Gas:	CO ₂ , O ₂ , N ₂ O, and any of the five anesthetic agents: DES, ISO, ENF, SEV and HAL.
Range:	CO ₂ : 0.0 to 30 % (0 to 30kPa, 0 to 226mmHg) O ₂ : 0 to 100 % N ₂ O : 0 to 100 % DES : 0.0 to 30 % SEV : 0.0 to 30 % ENF : 0.0 to 30 % ISO : 0.0 to 30 % HAL : 0.0 to 30 %

TABLE 10-23 AG Module

Resolution:	CO ₂ : 0.1 %		
	O ₂ : 1 %		
	N ₂ O : 1 %		
	DES : 0.1 %		
	SEV : 0.1 %		
	ENF : 0.1 %		
	ISO : 0.1 %		
HAL : 0.1 %			
ISO accuracy mode	Add ± 0.3 % _{ABS} to full accuracy for CO ₂ ; Add ± 8 % _{REL} to full accuracy for all agents; N ₂ O accuracy is ± (8 % _{REL} + 2 % _{ABS}).		
Full accuracy mode	CO ₂	0 to 1	± 0.1
		1 to 5 (not including 1)	± 0.2
	N ₂ O	5 to 7 (not including 5)	± 0.3
		7 to 10 (not including 7)	± 0.5
		> 10	Unspecified
		O ₂	0 to 20
	20 to 100 (not including 20)		± 3
	DES	0 to 25	± 1
		25 to 80 (not including 25)	± 2
		80 to 100 (not including 80)	± 3
		0 to 1	± 0.15
		1 to 5 (not including 1)	± 0.2
	SEV	5 to 10 (not including 5)	± 0.4
		10 to 15 (not including 10)	± 0.6
		15 to 18 (not including 15)	± 1
		> 18	Unspecified
	ENF, ISO, HAL	0 to 1	± 0.15
		1 to 5 (not including 1)	± 0.2
		5 to 8 (not including 5)	± 0.4
		> 8	Unspecified
		0 to 1	± 0.15
1 to 5 (not including 1)		± 0.2	
> 5		Unspecified	

TABLE 10-23 AG Module

Rise Time (10% to 90%)	Gas	Measured by using adult/pediatric water trap and 2.5m sampling line	Measured by using neonatal water trap and 2.5m sampling line
	CO ₂	≤250ms@150ml/min ≤250 ms@180ml/min ≤250 ms@200ml/min	≤250 ms@100ml/min ≤250 ms@110ml/min ≤250 ms@120ml/min
	N ₂ O	≤250ms@150ml/min ≤250 ms@180ml/min ≤250 ms@200ml/min	≤250 ms@100ml/min ≤250 ms@110ml/min ≤250 ms@120ml/min
	O ₂	≤500ms@150ml/min ≤500ms@180ml/min ≤500ms@200ml/min	≤600ms@100ml/min ≤600ms@110ml/min ≤600ms@120ml/min
	ENF	≤350ms@150ml/min ≤350 ms@180ml/min ≤350 ms@200ml/min	≤350 ms@100ml/min ≤350 ms@110ml/min ≤350 ms@120ml/min
	HAL, DES, SEV, ISO	≤300ms@150ml/min ≤300 ms@180ml/min ≤300 ms@200ml/min	≤300 ms@100ml/min ≤300 ms@110ml/min ≤300 ms@120ml/min
System Total Response Time	Gas	Measured by using adult/pediatric water trap and 2.5m sampling line	Measured by using neonatal water trap and 2.5m sampling line
	CO ₂	≤5 s @150ml/min ≤5 s @180ml/min ≤5 s @200ml/min	<6 s @100ml/min <6 s @110ml/min <6 s @120ml/min
	N ₂ O	≤5 s @150ml/min ≤5 s @180ml/min ≤5 s @200ml/min	<6 s @100ml/min <6 s @110ml/min <6 s @120ml/min
	O ₂	≤5 s @150ml/min ≤5 s @180ml/min ≤5 s @200ml/min	<6 s @100ml/min <6 s @110ml/min <6 s @120ml/min
	DES, SEV, ISO, HAL, ENF	≤5 s @150ml/min ≤5 s @180ml/min ≤5 s @200ml/min	<6 s @100ml/min <6 s @110ml/min <6 s @120ml/min
Primary agent ID threshold³	0.15% (0.4% during ISO accuracy mode)		
Secondary agent ID threshold⁴	0.3% (0.5% during ISO accuracy mode) or 5% _{REL} (10% _{REL} for Isoflurane) of primary agent if Primary agent >10%		
Measurement accuracy drift	Meets accuracy requirements within 6 hours		
Rate measurement	Measurement range: 2 bpm to 100 bpm Resolution: 1 bpm Measurement accuracy: 2 bpm to 60 bpm: ± 1 bpm 61 bpm to 100 bpm: ± 2 bpm		

TABLE 10-23 AG Module

1. Experiment condition: temperature of sampled gas is 37 °C, ambient temperature is 23 °C, relative humidity of sampled gas is 100%.
2. Cleaning time of watertrap ≥24h means that the liquid level will not exceed the MAX line within 24 hours.
3. For Halothane: Increase in threshold by 0.1%_{ABS}.
4. For Halothane: Increase in threshold by 0.1%_{ABS}.

- NOTE:** Inaccuracy specifications are affected by the breath rate and I:E change. The end-tidal gas reading is within specification for breath rate below 15BPM and I:E ratio smaller than 1:1 relative to the gas readings without breath; Add $\pm 6\%$ REL to inaccuracy for HAL and O₂ for breath rate larger than 15 BPM; Add $\pm 6\%$ REL to inaccuracy for all gases for breath rate larger than 30 BPM (inaccuracy for HAL and O₂ are unspecified in this case); inaccuracy is unspecified for breath rate larger than 60 BPM.
- NOTE:** The ability to properly resolve end-tidal values can be measured by using the set-up described in ISO 80601-2-55 figure 201.101. In short, the method consists of sampling gas from two different sources connected to an electrically controlled pneumatic valve to permit rapid switching between the two sources. During the test, the valve is set to switch gas source at a number of frequencies (simulating the range of specified breath rates) and for each frequency the end-tidal value presented by the gas analyzer is noted. From a diagram of end-tidal value over frequency, the frequency at which the gas analyzer is no longer able to resolve end-tidal values according to specification is identified. This ability to properly resolve end-tidal values is listed in the corresponding AION™ Multigas Analyzer technical specification.
- NOTE:** Data sample rate 25 Hz. Data presentation is 50 Hz, every second data point is interpolated.
- NOTE:** Inspiratory and end tidal CO₂ concentration readings are identified by AION™ Platinum Multigas Analyzers using the lowest and highest values respectively of the temporal CO₂-curve. Corresponding readings of N₂O and anesthetic agents are taken at the same point in time. Inspiratory and end-tidal O₂ concentration readings are identified by the O₂ mean value during the respiratory phase as identified by the temporal CO₂ curve. Once correctly identified, the highest and lowest O₂ concentration readings during each part of the phase will be presented as inspiratory and end-tidal O₂ respectively.
- NOTE:** The rated respiration rate measurement range for AG module is 2 to 100 bpm. The data sample rate is 25 Hz. The EtCO₂ concentration reading uses the highest value of the CO₂ waveform within the breathing cycle. The EtN₂O and EtAA concentration readings use the value measured at the moment when the EtCO₂ concentration is recorded. The FiO₂ concentration reading uses the highest value of the O₂ waveform within the breathing cycle.
- NOTE:** The rated respiration rate measurement range for AG module is calculated based on the CO₂ waveform. The test method used to determine the rated respiration rate range: Utilize the valves to switch the two sampling gases at different frequencies (simulating specified breath rates). Record the EtCO₂ value at each frequency. By drawing the coordinate diagram which indicates the corresponding relationship between end-tidal value and breathing frequency, the range of breathing frequency can be obtained.

10.10.1.1 Alarms

AG Alarm Limits	Range	Step	Unit
EtCO ₂ High Limit	Off, 2 to 99	1	mmHg (% and kPa should be optional)
EtCO ₂ Low Limit	Off, 0 to 97		
FiCO ₂ High Limit	Off, 1 to 99		

TABLE 10-24 Alarms

EtO ₂ High Limit	Off, 12 to 100	1	%
EtO ₂ Low Limit	Off, 10 to 98		
FiO ₂ High Limit	Off, 20 to 100		
FiO ₂ Low Limit	18 to 98		
EtN ₂ O High Limit	Off, 2 to 100	1	%
EtN ₂ O Low Limit	Off, 0 to 98		
FiN ₂ O High Limit	Off, 2 to 100		
FiN ₂ O Low Limit	Off, 0 to 98		
EtIso High Limit	Off, 0.2 to 5.0	0.1	%
EtIso Low Limit	Off, 0.0 to 4.8		
FiIso High Limit	Off, 0.2 to 5.0		
FiIso Low Limit	Off, 0.0 to 4.8		
EtSev High Limit	Off, 0.2 to 8.0	0.1	%
EtSev Low Limit	Off, 0.0 to 7.8		
FiSevHigh Limit	Off, 0.2 to 8.0		
FiSev Low Limit	Off, 0.0 to 7.8		
EtDes High Limit	Off, 0.2 to 18.0	0.1	%
EtDes Low Limit	Off, 0.0 to 17.8		
FiDes High Limit	Off, 0.2 to 18.0		
FiDes Low Limit	Off, 0.0 to 17.8		

TABLE 10-24 Alarms

10.10.1.2 Effect of Interfering Gas on AG Measured Value

Gas Under Test	Concentration	Quantitative Effect (Volume Fraction)							
		CO ₂	N ₂ O	HAL	SEV	ISO	ENF	DES	O ₂
N ₂ O	60 %	0.1%	/	0.1%	0.1%	0.1%	0.1%	0.1%	0.2%
HAL	4 %	0.1%	0.1%	/	0.1%	0.1%	0.1%	0.1%	1.0%
SEV	5 %	0.1%	0.1%	0.1%	/	0.1%	0.1%	0.1%	1.0%
ISO	5 %	0.1%	0.1%	0.1%	0.1%	/	0.1%	0.1%	1.0%
ENF	5 %	0.1%	0.1%	0.1%	0.1%	0.1%	/	0.1%	1.0%
DES	15 %	0.1%	0.1%	0.1%	0.1%	0.1%	0.1%	/	1.0%

NOTE: Test GAS LEVELS shall be $\pm 20\%$ of the specified level.

TABLE 10-25 Effect of Interfering Gas on AG Measured Value

10.10.2 Monitor Mode

The system supports **Monitor** mode when the anesthesia system is configured with an external AG module.

When the anesthesia system is in **Monitor** mode, the external AG module continues to function, while the ventilation monitors and alarms of the anesthesia system will be off.

10.10.3 Oxygen Monitor Using Oxygen Cell

Oxygen monitor	Type	Galvanic Fuel Cell
	Range	18 to 100 vol% O ₂
	Accuracy	±(volume fraction of 2.5%+2.5%gas level)
	Accuracy Drift	Meets accuracy requirements within 6 hours
	System Total Response Time (21% to 100% O ₂)	< 20 s

TABLE 10-26 Oxygen Monitor Using Oxygen Cell

10.10.3.1 Alarms

O ₂ Alarm Limits	Range	Step	Unit
FiO ₂ High Limit	Off, 20 to 100	1	%
FiO ₂ Low Limit	18 to 98		

TABLE 10-27 Alarms

10.10.3.2 Effect of Interfering Gas on Oxygen Cell Measured Value

Gas Under Test	Concentration	Quantitative Effect (Volume Fraction)
		O ₂
N ₂ O	60 %	1.0%
HAL	4 %	1.5% to 2.0%
SEV	5 %	1.0% to 1.5%
ISO	5 %	1.2% to 1.8%
ENF	5 %	1.2% to 1.8%
DES	15 %	2.0%

NOTE: Test GAS LEVELS shall be ± 20% of the specified level.

TABLE 10-28 Effect of Interfering Gas on Oxygen Cell Measured Value

10.10.4 Agent Usage Calculation and Agent Usage Speed

Agent Usage Calculation	
Calculation range:	0 to 3000 ml
Accuracy:	± 2 ml, or ± 15 % of the actual reading, whichever is greater.
Agent Usage Speed	
Anesthetic agents	Desflurane, Isoflurane and Sevoflurane
Usage speed range	Desflurane: 0 to 900 ml/h Sevoflurane: 0 to 450 ml/h Isoflurane: 0 to 250 ml/h
Accuracy	± 2ml/h or ±15% of the actual reading, whichever is greater.

TABLE 10-29 Agent Usage Calculation and Agent Usage Speed

10.11 Ventilator Specifications

General Ventilator Specifications	
Drive Pressure:	280 to 600 kPa
Maximum Inspiratory Flow:	180 L/min
Low Flow Anesthesia:	The accuracy of Tidal Volume shall be within the specification at 0.2L/min to 1L/min total fresh gas flow.

TABLE 10-30 General Ventilator Specifications

Ventilator Setting Parameter	Range
Apnea T _{insp} :	0.2 to 10 s, Step: 0.1 s
V _t (Under BTPS condition):	10 to 2000 ml (VCV, SIMV-VC), 5 to 2000 ml (PCV-VG, SIMV-VG), Step: 1 ml
RR:	4 to 100 bpm, Step: 1 bpm
Min RR:	2 to 60 bpm, Step: 1 bpm
I:E	4:1 to 1:8, Step: 0.5
Apnea I:E:	4:1 to 1:8, Step: 0.5
T _{insp} :	0.2 to 10 s, Step: 0.1 s
P _{insp} :	5 to 90cmH ₂ O, Step: 1 cmH ₂ O
ΔP _{insp} :	5 to 70cmH ₂ O, Step: 1 cmH ₂ O Note: ΔP _{insp} +PEEP not exceed 90cmH ₂ O
ΔP _{supp} :	0, 3 to 60cmH ₂ O Note: Under Pressure Support Ventilation Mode, ΔP _{supp} can be adjusted to 0, meaning CPAP mode. Step: 1 cmH ₂ O
ΔP _{apnea} :	3 to 60cmH ₂ O, Step: 1 cmH ₂ O
P _{limit} :	5 to 100 cmH ₂ O, Step: 1 cmH ₂ O
PEEP:	0 to 50 cmH ₂ O, Step: 1 cmH ₂ O
T _{pause} :	OFF, 5 to 60 % of T _{insp} , Step: 1 %
Trig Window:	5 to 80 % of T _{exp} , Step: 1 %
F-Trig:	0.2 to 15 L/min, Step: 0.1 L/min
P-Trig:	-20 to -1cmH ₂ O, Step: 1 cmH ₂ O
T _{slope} :	0.0 to 2.0 s, Step: 0.1 s
P _{high} :	3 to 90 cmH ₂ O, Step: 1 cmH ₂ O
P _{low} :	0 to 50 cmH ₂ O, Step: 1 cmH ₂ O
T _{high} :	0.2 to 10 s, Step: 0.1 s
T _{low} :	0.2 to 10 s, Step: 0.1 s
Exp%	5 to 80 %, Step: 1 %

TABLE 10-31 Ventilator Setting Parameter and Range

Ventilator Monitored Parameters	Range
PEAK:	-20 to 120 cmH ₂ O
PLAT:	-20 to 120 cmH ₂ O
MEAN:	-20 to 120 cmH ₂ O
PEEP:	0 to 70 cmH ₂ O
Tidal Volume (Vt/Vt insp) (Under BTPS condition):	0 to 3000 ml
Minute Volume (MV/MV insp) (Under BTPS condition):	0 to 100 L/min
RR:	0 to 150 bpm
I:E:	4:1 to 1:10
Raw:	0 to 600 cmH ₂ O/(L/s)
Compl:	0 to 300 mL/cmH ₂ O
MVLeak (Under BTPS condition):	0 to 10 L/min

TABLE 10-32 Ventilator Monitored Parameters and Range

Control Parameters	Accuracy
Vt (VCV, SIMV-VC, under BTPS condition):	10 to 60 ml: ± 10 ml 60 to 210 ml (not including 60 ml): ± 15 ml 210 to 2000 ml (not including 210 ml): ± 7 % of the setting value
Vt (PCV-VG, SIMV-VG, under BTPS condition):	5 to 60 ml: ± 10 ml 60 to 210 ml (not including 60 ml): ± 15 ml 210 to 2000 ml (not including 210 ml): ± 7 % of the setting value
Pinsp:	± 2.0 cmH ₂ O or ± 7 % of the setting value, whichever is greater, but is not more than ±5 cmH ₂ O
ΔPinsp:	
ΔPsupp:	± 2.0 cmH ₂ O or ± 7 % of the setting value, whichever is greater
ΔPapnea:	
Plimit:	±10% of the setting value
PEEP	± 2.0 cmH ₂ O or ± 7 % of the setting value, whichever is greater
Tslope:	± 0.2 s or ± 20 % of the setting value, whichever is greater
RR:	± 1 bpm or ± 10 % of the setting value, whichever is smaller
Min RR:	
I:E:	2:1 to 1:4: ±10% of the setting value
Apnea I:E:	Other range: ±25% of the setting value
Apnea Tinsp:	± 0.2 s
Tinsp:	
Tpause:	±8 % (absolute error)
Trig Window:	±10 % (absolute error)
F-Trig:	±1 L/min
P-Trig:	± 2.0 cmH ₂ O

TABLE 10-33 Ventilator Control Accuracy

Phigh:	± 2.0 cmH ₂ O or $\pm 7\%$ of the setting value, whichever is greater, but is not more than ± 5 cmH ₂ O
Plow:	± 2.0 cmH ₂ O or $\pm 7\%$ of the setting value, whichever is greater
Thigh:	± 0.2 s or $\pm 10\%$ of the setting value, whichever is greater
Tlow:	
Exp%	$\pm 10\%$ (absolute error)

TABLE 10-33 Ventilator Control Accuracy

Monitored Parameters	Accuracy
Vt/Vt insp (under BTPS condition):	0 to 60 ml: ± 10 ml 60 to 210 ml (not including 60 ml): ± 15 ml 210 to 3000 ml (not including 210 ml): $\pm 7\%$ of the actual reading
MV/MV insp (under BTPS condition):	$\pm 15\%$ of the actual reading, repeatable to $\pm 5\%$ over a 1h period
PEAK:	± 2.0 cmH ₂ O or $\pm 4\%$ of the actual reading, whichever is greater
PLAT:	
MEAN:	
PEEP:	
RR:	± 1 bpm or $\pm 5\%$ of the actual value, whichever is smaller
I:E:	2:1 to 1:4: $\pm 10\%$ of the actual reading 4:1 to 2:1 and 1:4 to 1:10 (not including 2:1 and 1:4): $\pm 25\%$ of the actual reading
Raw:	0 to 20 cmH ₂ O/(L/s): ± 10 cmH ₂ O/(L/s) 20 to 600 cmH ₂ O/(L/s) (not including 20 cmH ₂ O/(L/s)): $\pm 50\%$ of the actual reading
Compl:	$\pm (10$ mL/cmH ₂ O+20% of the actual reading)
MVLeak (under BTPS condition):	± 0.1 L/min or $\pm 8\%$ of the actual reading, whichever is greater

TABLE 10-34 Ventilator Monitoring Accuracy

Lung Recruitment	
Lung Recruitment Tool includes Multi-step Recruitment and One-step Recruitment.	
Pressure Hold:	Range: 20 to 60 cmH ₂ O
Hold Time:	Range: 10 to 40 s
PEEP on Exit*:	Range: 0 to 50 cmH ₂ O
Cycle Interval:	Range: Off, 1 to 180 min

* When the ventilation mode is APRV before entering the recruitment, the button name **PEEP on Exit** will indicate **Plow on Exit**.

TABLE 10-35 Lung Recruitment Tool

10.12 Displays and Controls Specifications

10.12.1 Electronic Controls

Main Display:	Color LCD is 18.5inch diagonal, 1920 * 1080 resolution, touch screen
Status Display:	Color LCD is 8.4 inch diagonal, 800 * 600 resolution
AC Power Indicator LED:	Green illuminated = active AC power Not illuminated = inactive AC power
Battery Status Indicator (LED):	Solid green illuminated = battery supply is charging Not illuminated = battery supply is discharging or not charging
Working Light:	Settings: Off, Low, High
Mouse:	The Anesthesia System utilizes the SB port for a wired mouse that allows control of the touch screen.

TABLE 10-36 Electronic Controls

10.12.2 Pneumatic Controls

Line Pressure Gauges:	Gauges: O ₂ , N ₂ O, Air Range: 0 to 140 psi (0 to 1000 kPa) Accuracy: ± (4 % of full scale reading + 8 % of actual reading) Units of measure: kPa, psi
Cylinder Pressure Gauges:	Gauges: O ₂ , N ₂ O, Air O ₂ : 0 to 3500 psi (0 to 25 MPa) N ₂ O: 0 to 1400 psi (0 to 10 MPa) Air: 0 to 3500 psi (0 to 25 MPa) Accuracy: ± (4 % of full scale reading + 8 % of actual reading) Units of measure: kPa, psi
Electronic Flowmeter:	<p>Direct Flow Control Mode: O₂ flow range: 0.00 L/min, 0.20 to 15.0 L/min Air flow range: 0.00 to 15.0 L/min N₂O flow range: 0.00 to 12.0 L/min O₂ flow accuracy: ± 50 mL/min or ± 5 % of setting value, whichever is greater Balance gas (Air/N₂O) flow accuracy: ± 50 mL/min or ± 5 % of setting value, whichever is greater O₂ concentration range in the O₂/N₂O mixed gas: ≥ 25 %</p> <p>Total Flow Control Mode: Total flow range: 0.00 L/min, 0.20 to 20.0 L/min Total flow accuracy: ± 100 mL/min or ± 5 % of setting value, whichever is greater O₂ concentration range: 21 % to 100 % (The balance gas is Air) 26 % to 100 % (The balance gas is N₂O) O₂ concentration accuracy: Volume fraction of ±5% (Flow <1L/min) ± 5 % of the setting value (Flow ≥1L/min)</p>

TABLE 10-37 Pneumatic Controls

Backup Flowmeter, Control Needle Valve and Knob:	<p>Flow display on screen: O₂ basal flow: 1.0 L/min O₂ basal flow accuracy: ± 0.5 L/min O₂ flow range: O₂ basal flow to 15 L/min Air flow range: 0 to 15 L/min Flowmeter display accuracy: ± 10 % of the indicated value (under the condition of 20°C and 101.3kPa, for flow between 10% and 100% of full scale) Rotations: 3.5 to 4.5 (O₂ from minimum flow to maximum flow) 4 to 5 (Air from minimum flow to maximum flow)</p> <p>Glass tube flow display: Glass tube flowmeter display range: 0 to 15 L/min Flowmeter display accuracy: ± 10 % of the indicated value (under the condition of 20°C and 101.3kPa, for flow between 10% and 100% of full scale)</p>
High Flow Nasal Cannula Oxygen (HFNC)	O ₂ concentration setting range: 21 % to 100 % O ₂ concentration control accuracy: Volume fraction of ± 5 % Flow control range: 2 L/min to 60 L/min Flow control accuracy: ± (2 L/min + 10 % of the setting value) Out pressure (normal condition): ≤ 1.5kPa
High Pressure Oxygen Outlet:	Pressure range: 280 to 600 kPa Maximum flow: ≥ 90 L/min
O₂ Flush:	Flow range: 35 to 50 L/min
Airway Pressure Gauge:	Range: -20 to 100 cmH ₂ O Accuracy: ± (2 % of full scale reading + 4 % of actual reading)

TABLE 10-37 Pneumatic Controls

10.13 Alarms

Alarm Indicators:	Audible: speaker Visual: alarm light and on-screen alarm messages (Audible and visual alarms comply with the requirements of IEC 60601-1-8.)
Alarm Categories:	Physiological alarms: three levels (high, medium, low) Technical alarms: three levels (high, medium, low)
Sound Levels:	10 alarm sound levels, adjustable (levels 1 to 10)

TABLE 10-38 Alarms

Vte:	High Limit	5mL to 2200mL
	Low Limit	OFF, 0mL to 2195mL
MV:	High Limit	0.2L/min to 100L/min
	Low Limit	0.0L/min to 99L/min
RR:	High Limit	4bpm to 100bpm, OFF
	Low Limit	OFF, 2bpm to 98bpm
Paw:	High Limit	2cmH ₂ O to 100cmH ₂ O
	Low Limit	0cmH ₂ O to 98cmH ₂ O

TABLE 10-39 Alarm Limits

Apnea alarm delay time is adjustable, Range: 5s to 60s, Accuracy: ±3s
 CO₂ apnea delay time is adjustable, Range: 10s to 40s, Accuracy: ±3s

It has Negative Pressure alarm function, when **Negative Pressure in Airway** alarm is triggered, Paw shall be less than -10cmH₂O.

TABLE 10-39 Alarm Limits

10.14 Response Time of the Anesthesia System to an Increase in O₂ Concentration (From 21% to 90%/100%)

Ventilator setting: TV=500 ml, Freq=10 bpm, I:E=1:2

Fresh Gas(L/min)	O ₂ Flush	Response Time From 21% to 90%	Response Time From 21% to 100%
1.0	Without O ₂ Flush	10 minutes	20 minutes
	With O ₂ Flush	30 seconds	1 minute
5.0	Without O ₂ Flush	1 minute 30 seconds	4 minutes
	With O ₂ Flush	30 seconds	1 minute
10.0	Without O ₂ Flush	30 seconds	1 minute
	With O ₂ Flush	30 seconds	1 minute

TABLE 10-40 Response Time of the Anesthesia System to an Increase in O₂ Concentration (From 21% to 90%/100%)

A.0

Accessories

- WARNING:** Please use the accessories specified in this chapter only. Using other accessories may lead to inaccurate measurements or equipment faults.
- WARNING:** Disposable accessories must be used only once. Repeated use may lead to deterioration in performance or cross-infection.
- WARNING:** Please do not use the accessory if its package or itself is damaged.
- WARNING:** At the end of its service life, the equipment, as well as its accessories, must be disposed of in compliance with the guidelines regulating the disposal of such products, and in accordance with local regulations for contaminated and biologically hazardous items.
- WARNING:** Parts which are intended to contact patients must comply with the biocompatibility requirement of ISO 10993-1 to prevent any adverse reactions arising from such contact.

TYPE	PART NUMBER	DESCRIPTION
Vaporizer	115-066755-00	Sevoflurane (Quik-Fil) Electronic vaporizer material package
	115-066756-00	Sevoflurane (Safety Filling adapter) Electronic vaporizer material package
	115-066758-00	Isoflurane (Safety Filling adapter) Electronic vaporizer material package
	115-066759-00	Desflurane (Saf-T-Fill) Electronic vaporizer material package
	115-064146-00	Safety Filling adapter (Sevoflurane)
	115-064147-00	Safety Filling Adapter (Isoflurane)
	115-026747-00	Mindray Quik-Fil filling adapter for sevoflurane
AG Accessories	115-051561-00	Multi-gas module with accessory kit (2-slot)
	115-058733-00	DRYLINE II Watertrap (adult/pediatric, reusable, 2-slot)
	115-058734-00	DRYLINE II Watertrap (neonate, reusable, 2-slot)
	115-043017-00	Sampling line (adult/pediatric, disposable)
	115-043018-00	Sampling line (neonate, disposable)
	115-043020-00	Airway adapter (straight, disposable)
CO ₂ Absorbent Canister	0683-00-0326-12	CO ₂ Absorbent, Pre-Pak (12)
	0348-00-0185	Washer, Seal for Cylinder
Gas Cylinder Accessories	115-033063-00	Cylinder wrench assembly

TYPE	PART NUMBER	DESCRIPTION	
Gas Supply Hoses	0004-00-0077-11	O2 Gas Supply Hose, 15 ft, Ohmeda	
	0004-00-0077-12	O2 Gas Supply Hose, 15 ft, Chemetron	
	0004-00-0077-13	O2 Gas Supply Hose, 15 ft, Puritan Bennett	
	0004-00-0077-14	O2 Gas Supply Hose, 15 ft, DISS Female	
	0004-00-0078-11	N2O Gas Supply Hose, 15 ft, Ohmeda	
	0004-00-0078-12	N2O Gas Supply Hose, 15 ft, Chemetron	
	0004-00-0078-13	N2O Gas Supply Hose, 15 ft, Puritan Bennett	
	0004-00-0078-14	N2O Gas Supply Hose, 15 ft, DISS Female	
	0004-00-0079-11	Air Gas Supply Hose, 15 ft, Ohmeda	
	0004-00-0079-12	Air Gas Supply Hose, 15 ft, Chemetron	
	0004-00-0079-13	Air Gas Supply Hose, 15 ft, Puritan Bennett	
	0004-00-0079-14	Air Gas Supply Hose, 15 ft, DISS Female	
	0004-00-0080-13	VAC Gas Supply Hose, 15 ft, Ohmeda	
	0004-00-0080-14	VAC Gas Supply Hose, 15 ft, Chemetron	
	0004-00-0080-15	VAC Gas Supply Hose, 15 ft, Puritan Bennett	
	0004-00-0080-16	VAC Gas Supply Hose, 15 ft, DISS Female	
	0004-00-0081-11	EVAC Gas Supply Hose, 15 ft, Ohmeda	
	0004-00-0081-12	EVAC Gas Supply Hose, 15 ft, Chemetron	
	0004-00-0081-13	EVAC Gas Supply Hose, 15 ft, Puritan Bennett	
	0004-00-0081-14	EVAC Gas Supply Hose, 15 ft, DISS Female	
	0004-00-0081-31	EVAC DISS to VAC Ohmeda Gas Supply Hose, 15 ft	
	0004-00-0081-32	EVAC DISS to VAC Chemetron Gas Supply Hose, 15 ft	
	0004-00-0081-33	EVAC DISS to VAC Puritan Bennett Gas Supply Hose, 15 ft	
	0004-00-0081-34	EVAC DISS to VAC DISS Female Gas Supply Hose, 15 ft	
	Manuals and Reference Cards	046-019163-00	A8/A9 Disinfection/Cleaning Card
		046-019101-00	A8/A9 Pre-Operation Checklist(English)
	Mounting Accessories	115-066029-00	Bracket for N12/15/17/ePM15, variable
		115-066074-00	Bracket for N12/15/17/ePM15, fixed
		115-069443-00	Bracket for N19/N22, fixed
		034-000460-00	GCX 12" x 12" Articulating Arm with Tray
		0436-00-0259	Mount, Suction Canister
		008-000468-00	CPU Mount 3-4.5"/7.6-11.4 cm wide
		008-000468-01	CPU Mount 1.5-3"/3.8-7.6 cm wide
		008-000468-02	CPU Mount 4.5-7"/11.4-17.8 cm wide
008-000468-03		CPU Mount 7-9.5"/17.8-24.1 cm wide	
115-069445-00		Top shelf upgrade kit	
115-070794-00		Bracket kit for N15/17, fixed	
115-074073-00		Bracket kit for N12, fixed	
034-000288-00		Bracket for CIS system	
Networking and USB Storage		0012-00-1274-06	CAT 5 Ethernet Cable, Patch, STP, 3' (0.91 m)
	0012-00-1392-06	CAT 5 Ethernet Cable, Crossover, STP, 6' (1.83 m)	
	023-000361-00	USB Wired Mouse	
	023-001673-00	USB Storage Device, 8GB	

TYPE	PART NUMBER	DESCRIPTION
Scavenging Accessories	115-037548-00	Passive scavenging kit
	115-026796-00	AGSS 3-way connector assembly
	115-052162-00	AG exhaust gas outlet assembly
Negative Pressure Suction Device	115-033264-00	Suction accessories such as filters and hoses
	082-001327-00	Filter
	115-054836-00	suction canister mounting bracket
O ₂ Cell	040-001270-00	O ₂ sensor
	115-064181-00	Base for O ₂ cell
Flow Sensor	115-041507-00	Inspiration flow sensor component
	115-041508-00	Expiration flow sensor component
	115-041519-00	Flow sensor component
Others	040-000733-00	Fisher&Paykel 810 humidifier
	115-052161-00	Quick connector (0632/sampling return)
	115-052370-00	Quick connector (0632/sampling return/1.5m)
	043-010620-00	Hook
	115-048035-00	Flexible arm assembly

Parameters and Factory Defaults

Spirometry Screen.....	B-2
Limits.....	B-2
Main Menu.....	B-3
Screen Brightness.....	B-5
Volume.....	B-5
History.....	B-6
Lung Recruitment.....	B-6
Fresh Gas Control.....	B-6
Patient Information.....	B-6
Ventilation Mode.....	B-7
Ventilation Linkage Parameters.....	B-10
Constraints Among Ventilation Parameters.....	B-14

B.1 Spirometry Screen

ITEM	DEFAULT
Loop Type	P-V loop, F-V loop
Save Loop	Baseline loop
Show Reference	Off
Review Loops	P-V loop

B.2 Limits

PARAMETERS	DEFAULT
Alarms: Limits: PEAK High	Adult: 50 cmH ₂ O Pediatric: 40 cmH ₂ O Neonate: 40 cmH ₂ O
Alarms: Limits: PEAK Low	Adult: 10 cmH ₂ O Pediatric: 8 cmH ₂ O Neonate: 8 cmH ₂ O
Alarms: Limits: MV High	Adult: 12 L/min Pediatric: 6 L/min Neonate: 6 L/min
Alarms: Limits: MV Low	Adult: 1 L/min Pediatric: 1 L/min Neonate: 0.2 L/min
Alarms: Limits: Vte High	1000 ml
Alarms: Limits: Vte Low	Off
Alarms: Limits: RR High	Off
Alarms: Limits: RR Low	Off
Alarms: Limits: EtCO ₂ High	Adult or Pediatric: 50 mmHg Neonate: 45 mmHg
Alarms: Limits: EtCO ₂ Low	Adult or Pediatric: 25 mmHg Neonate: 30 mmHg
Alarms: Limits: FiCO ₂ High	4 mmHg
Alarms: Limits: Apnea Delay Time	30 sec
Alarms: Limits: CO ₂ Apnea Delay Time	30 sec
Alarms: Limits: FiO ₂ High	Off
Alarms: Limits: FiO ₂ Low	18 %
Alarms: Limits: EtO ₂ High	88 %
Alarms: Limits: EtO ₂ Low	Off
Alarms: Limits: FiN ₂ O High	53 %
Alarms: Limits: FiN ₂ O Low	0 %
Alarms: Limits: EtN ₂ O High	55 %
Alarms: Limits: EtN ₂ O Low	0 %
Alarms: Limits: AGSS Alarms	On
Alarms: Agents: EtIso High	3 %
Alarms: Agents: EtIso Low	0 %
Alarms: Agents: Filso High	2 %

PARAMETERS	DEFAULT
Alarms: Agents: Filso Low	0 %
Alarms: Agents: EtSev High	6 %
Alarms: Agents: EtSev Low	0 %
Alarms: Agents: FiSev High	5 %
Alarms: Agents: FiSev Low	0 %
Alarms: Agents: EtDes High	8 %
Alarms: Agents: EtDes Low	0 %
Alarms: Agents: FiDes High	6 %
Alarms: Agents: FiDes Low	0 %

B.3 Main Menu

PARAMETERS	DEFAULT
Setup: Ventilation: Vt/IBW	7 ml/Kg
Setup: Ventilation: Vt Source	IBW
Setup: Ventilation: Time Control	I:E
Setup: Ventilation: Pressure Display	PLAT
Setup: Ventilation: Plimit Line	On
Setup: Ventilation: Breathing System Warmer	On
Setup: AG: CO ₂ Scale	0-60 mmHg
Setup: AG: O ₂ Scale	0-100 %
Setup: AG: N ₂ O Scale	0-100 %
Setup: AG: Des Scale	0-9.0 %
Setup: AG: Sev Scale	0-4.0 %
Setup: AG: Iso Scale	0-2.5 %
Setup: AG: Flow Rate	High
Setup: Screen: CO ₂ Location	Top
Setup: Screen: Screen Saver	30 min
Setup: System: Setup: Ventilation: Insp Pressure	Pinsp
Setup: System: Setup: Quick Key: Alarm Reset	On
Setup: System: Setup: Quick Key: Capture Event/Screen	On
Setup: System: Setup: Quick Key: Lung Recruitment	On
Setup: System: Setup: Quick Key: Flow Pause	On
Setup: System: Setup: Quick Key: Bypass in Auto mode	Off
Setup: System: Setup: AG: Null for 30s from zeroing	On
Setup: System: Setup: AG: Types of Agent	Hal, Enf, Iso, Sev, Des
Setup: System: Setup: Ventilation: Multi-Step Recruitment	On
Setup: System: Setup: Ventilation: One-Step Recruitment	On
Setup: System: Setup: Language/Unit: Language	English
Setup: System: Setup: Language/Unit: Pressure Unit	cmH ₂ O
Setup: System: Setup: Language/Unit: CO ₂ Unit	mmHg
Setup: System: Setup: Language/Unit: Gas Supply Pressure	kPa

PARAMETERS	DEFAULT
Setup: System: Setup: Language/Unit: Agent Cost Unit	\$
Setup: System: Setup: Language/Unit: Patient Height	inch
Setup: System: Setup: Language/Unit: Patient Weight	Lbs
Setup: System: Setup: Optimizer: Optimizer	On
Setup: System: Setup: Optimizer: Agent Usage	On
Setup: System: Setup: Optimizer: Cost/ml of Liquid Agent: Sev	0.00
Setup: System: Setup: Optimizer: Cost/ml of Liquid Agent: Des	0.00
Setup: System: Setup: Optimizer: Cost/ml of Liquid Agent: Iso	0.00
Setup: System: Setup: History: Clear History	Off
Setup: System: Setup: Time/Date: 24 Hour Time	Off
Setup: System: Setup: Time/Date: Time Zone	UTC-05:00
Setup: System: Setup: Time/Date: Time	00(24h),12AM(12h)
Setup: System: Setup: Time/Date: Date Format	YYYY-MM-DD
Setup: System: Setup: Time/Date: Date	2009-1-1
Setup: System: Setup: Time/Date: Daylight Savings Time	Off
Setup: System: Setup: Time/Date: Start: Week of the Month	First
Setup: System: Setup: Time/Date: Start: Day of the Week	Sunday
Setup: System: Setup: Time/Date: Start: Month	Apr
Setup: System: Setup: Time/Date: Start: Time	2:00 AM
Setup: System: Setup: Time/Date: End: Week of the Month	Last
Setup: System: Setup: Time/Date: End: Day of the Week	Sunday
Setup: System: Setup: Time/Date: End: Month	Oct
Setup: System: Setup: Time/Date: End: Time	3:00 AM
Setup: System: Setup: Flow Control: Quick Key 1: L/min	1
Setup: System: Setup: Flow Control: Quick Key 1: %O ₂	100
Setup: System: Setup: Flow Control: Quick Key 2: L/min	2
Setup: System: Setup: Flow Control: Quick Key 2: %O ₂	100
Setup: System: Setup: Flow Control: Quick Key 3: L/min	5
Setup: System: Setup: Flow Control: Quick Key 3: %O ₂	100
Setup: System: Setup: Flow Control: Quick Key 4: L/min	10
Setup: System: Setup: Flow Control: Quick Key 4: %O ₂	100
Setup: System: Setup: Flow Control: Total Flow	2.0 L/min
Setup: System: Network: Ethernet: Obtain IP Address Automatically	Off
Setup: System: Network: Ethernet: IP Address	192.168.23.250
Setup: System: Network: Ethernet: Subnet	255.255.255.0
Setup: System: Network: Ethernet: Default Gateway	-
Setup: System: Network: Ethernet: Obtain DNS Server Address Automatically	Off
Setup: System: Network: Ethernet: Preferred DNS Server	-
Setup: System: Network: Ethernet: Alternate DNS Server	-
Setup: System: Network: Ethernet: Device Name	-
Setup: System: Network: Serial: Protocol	None
Setup: System: Network: Serial: Baud Rate	115200

PARAMETERS	DEFAULT
Setup: System: Network: Serial: Data Bits	8
Setup: System: Network: Serial: Stop Bits	1
Setup: System: Network: Serial: Parity	None
Setup: System: Network: Serial: Data Internal	1 min
Setup: System: Network: HL7: Data+Waveforms: Destination IP	192.168.23.200
Setup: System: Network: HL7: Data+Waveforms: Port	1550
Setup: System: Network: HL7: Data+Waveforms: Data Internal	Off
Setup: System: Network: HL7: Data+Waveforms: Compatibility	Most Recent
Setup: System: Network: HL7: Data+Waveforms: Send Waveforms	Off
Setup: System: Network: HL7: Alarms: Destination IP	192.168.23.200
Setup: System: Network: HL7: Alarms: Port	1550
Setup: System: Network: HL7: Alarms: Compatibility	Most Recent
Setup: System: Network: HL7: Alarms: Send Alarms	Off
Setup: System: Network: HL7: Alarms: Send Alarm Ack	Off
Setup: System: Network: MD2: MD2	Off
Setup: System: Network: MD2: Destination IP	192.168.23.99
Setup: System: Network: MD2: Port	6678
Setup: System: Network: SNTP: Interval	Off
Setup: System: Network: SNTP: Primary Server IP Address	132.163.4.103
Setup: System: Network: SNTP: Secondary Service IP Address	210.72.145.44
Setup: System: Network: ADT: ADT	Off
Setup: System: Network: ADT: Destination IP	192.168.23.99
Setup: System: Network: ADT: Port	3502
Setup: System: Network: Optimizer Source: IP Address	-
Setup: System: Network: Optimizer Source: Multicast Address	255.0.0.8

B.4 Screen Brightness

PARAMETERS	DEFAULT
Main Screen	50% of maximum brightness
Status Screen	50% of maximum brightness

B.5 Volume

PARAMETERS	DEFAULT
Alarm Volume	30% of maximum volume
System Alert Volume	30% of maximum volume
Key Click Volume	30% of maximum volume

B.6 History

PARAMETERS	DEFAULT
List Trends: Show Interval	1 min
List Trends: Show Group	All
Graphic Trends: Zoom	5 min
Graphic Trends: Show Group	All
Event Log: Filter	High

B.7 Lung Recruitment

PARAMETERS	DEFAULT
Multi-Step Recruitment: Select Procedure	Procedure 1
One-Step Recruitment: Pressure Hold	Adult: 35 cmH ₂ O Pediatric: 20 cmH ₂ O
One-Step Recruitment: Hold Time	15 sec

B.8 Fresh Gas Control

PARAMETERS	DEFAULT
Fresh Gas Control: Control Mode	Total Flow
Fresh Gas Control: Balance Gas	AIR
Fresh Gas Control: Purge Flow Rate	10 L/min
Fresh Gas Control: Total Flow: Total	2.0 L/min
Fresh Gas Control: Total Flow: O ₂ %	100 %
Fresh Gas Control: Direct Flow: O ₂	2.0 L/min
Fresh Gas Control: Direct Flow: AIR	0.0 L/min
Fresh Gas Control: Direct Flow: N ₂ O	0.0 L/min
Fresh Gas Control: Direct Flow: None	0.0 L/min

B.9 Patient Information

PARAMETERS	DEFAULT
Patient Size	Neonate
Gender	Unspecified
Height	—
IBW	—
Weight	—
Age	—
Patient ID	—
Visit Number	—
First Name	—

PARAMETERS	DEFAULT
Last Name	—
DOB	—
Bed	—
Room	—
Department	—
Facility	—

B.10 Ventilation Mode

ITEM	DEFAULT
Ventilation Mode Tab	VCV

PARAMETERS	VCV	SIMV-VC	PCV	PCV-VG	SIMV-PC	CPAP/PS	SIMV-VG	APRV	MANUAL
Vt	Adult: 600 mL Pediatric: 120 mL Neonate: 20 mL	Adult: 600 mL Pediatric: 120 mL Neonate: 20 mL	—	Adult: 600 mL Pediatric: 120 mL Neonate: 20 mL	—	—	Adult: 600 mL Pediatric: 120 mL Neonate: 20 mL	—	—
RR	Adult: 8 bpm Pediatric: 15 bpm Neonate: 20 bpm	Adult: 8 bpm Pediatric: 15 bpm Neonate: 20 bpm	Adult: 8 bpm Pediatric: 15 bpm Neonate: 20 bpm	Adult: 8 bpm Pediatric: 15 bpm Neonate: 20 bpm	Adult: 8 bpm Pediatric: 15 bpm Neonate: 20 bpm	—	Adult: 8 bpm Pediatric: 15 bpm Neonate: 20 bpm	—	—
Min. RR	—	—	—	—	—	Adult: 4 bpm Pediatric: 6 bpm Neonate: 12 bpm	—	—	—
I:E	1:2	—	1:2	1:2	—	—	—	—	—
T_{insp}	—	Adult: 2.0 s Pediatric: 1.0 s Neonate: 1.0 s	—	—	Adult: 2.0 s Pediatric: 1.0 s Neonate: 1.0 s	—	Adult: 2.0 s Pediatric: 1.0 s Neonate: 1.0 s	—	—
P_{insp}	—	—	Adult: 15 cmH ₂ O Pediatric: 10 cmH ₂ O Neonate: 10 cmH ₂ O	—	Adult: 15 cmH ₂ O Pediatric: 10 cmH ₂ O Neonate: 10 cmH ₂ O	—	—	—	—
ΔP_{insp}	—	—	Adult: 15 cmH ₂ O Pediatric: 10 cmH ₂ O Neonate: 10 cmH ₂ O	—	Adult: 15 cmH ₂ O Pediatric: 10 cmH ₂ O Neonate: 10 cmH ₂ O	—	—	—	—
T_{pause}	10 %	10 %	—	—	—	—	—	—	—
P_{limit}	Adult: 50 cmH ₂ O Pediatric: 40 cmH ₂ O Neonate: 20 cmH ₂ O	Adult: 50 cmH ₂ O Pediatric: 40 cmH ₂ O Neonate: 20 cmH ₂ O	—	Adult: 50 cmH ₂ O Pediatric: 40 cmH ₂ O Neonate: 20 cmH ₂ O	—	—	Adult: 50 cmH ₂ O Pediatric: 40 cmH ₂ O Neonate: 20 cmH ₂ O	—	—

PARAMETERS	VCV	SIMV-VC	PCV	PCV-VG	SIMV-PC	CPAP/PS	SIMV-VG	APRV	MANUAL
PEEP	0 cmH ₂ O	0 cmH ₂ O	0 cmH ₂ O	0 cmH ₂ O	0 cmH ₂ O	0 cmH ₂ O	0 cmH ₂ O	—	—
ΔPsupp	—	Adult: 8 cmH ₂ O Pediatric: 5 cmH ₂ O Neonate: 5 cmH ₂ O	—	—	Adult: 8 cmH ₂ O Pediatric: 5 cmH ₂ O Neonate: 5 cmH ₂ O	Adult: 8 cmH ₂ O Pediatric: 5 cmH ₂ O Neonate: 5 cmH ₂ O	Adult: 8 cmH ₂ O Pediatric: 5 cmH ₂ O Neonate: 5 cmH ₂ O	—	—
F-Trig	—	Adult: 3 L/min Pediatric: 2 L/min Neonate: 2 L/min	—	—	Adult: 3 L/min Pediatric: 2 L/min Neonate: 2 L/min	Adult: 3 L/min Pediatric: 2 L/min Neonate: 2 L/min	Adult: 3 L/min Pediatric: 2 L/min Neonate: 2 L/min	—	—
P-Trig	—	-3 cmH ₂ O	—	—	-3 cmH ₂ O	-3 cmH ₂ O	-3 cmH ₂ O	—	—
Trig Window	—	25%	—	—	25%	—	25%	—	—
Tslope	—	0.2 s	0.2 s	0.2 s	0.2 s	0.2 s	0.2 s	0.2 s	—
Exp%	—	25 %	—	—	25 %	25 %	25 %	—	—
ΔPapnea	—	—	—	—	—	Adult: 15 cmH ₂ O Pediatric: 10 cmH ₂ O Neonate: 10 cmH ₂ O	—	—	—
Apnea I:E	—	—	—	—	—	1:2	—	—	—
Apnea Ti	—	—	—	—	—	Adult: 2.5 s Pediatric: 1.5 s Neonate: 1.0 s	—	—	—
Phigh	—	—	—	—	—	—	—	15 cmH ₂ O	—
Plow	—	—	—	—	—	—	—	5 cmH ₂ O	—
Thigh	—	—	—	—	—	—	—	Adult: 2.5 s Pediatric: 1.3 s Neonate: 1.0 s	—
Tlow	—	—	—	—	—	—	—	Adult: 5.0 s Pediatric: 2.7s Neonate: 2.0 s	—
Alarm	—	—	—	—	—	—	—	—	On
CO ₂ Alarms	—	—	—	—	—	—	—	—	On

B.11 Ventilation Linkage Parameters

The table below describes how ventilation mode changes impact parameter values. For example, when the ventilation mode changes, its parameter values may be shared by the other ventilation mode with the same parameters. When the ventilation mode changes, other parameters may have different values set.

CURRENT VENTILATION MODE & AFFECTED PARAMETERS		PREVIOUS VENTILATION MODE							
		VCV	SIMV-VC	PCV	PCV-VG	SIMV-PC	CPAP/PS	SIMV-VG	APRV
VCV	Vt	—	*	Vti measurement or the closest approximation	*	#	#	*	#
	RR	—	*	*	*	*	#	*	#
	I:E	—	#	*	*	#	#	#	#
	Tpause	—	*	#	#	#	#	#	#
	PEEP	—	*	*	*	*	*	*	#
	Plimit	—	*	#	*	#	#	*	#
SIMV-VC	Vt	*	—	Vti measurement or the closest approximation	*	#	#	*	#
	RR	*	—	*	*	*	#	*	#
	Tinsp	#	—	#	#	*	#	*	#
	Tpause	*	—	#	#	#	#	#	#
	PEEP	*	—	*	*	*	*	*	#
	Plimit	*	—	#	*	#	#	*	#
	ΔPsupp	#	—	#	#	*	*	*	#
	F-Trig/P-Trig	#	—	#	#	*	*	*	#
	Exp%	#	—	#	#	*	*	*	#
	Trig Window	#	—	#	#	*	#	*	#
	Tslope	#	—	*	*	*	*	*	*

* In the event that the previous ventilation mode and the current one share some parameter values, the parameter setting remains unchanged.
 # For the parameters that are not shared by the previous ventilation mode and the current one, the most recent settings of the parameters apply.

CURRENT VENTILATION MODE & AFFECTED PARAMETERS		PREVIOUS VENTILATION MODE							
		VCV	SIMV-VC	PCV	PCV-VG	SIMV-PC	CPAP/PS	SIMV-VG	APRV
PCV	P _{insp}	PLAT or 80% of PEAK or the closest approximation	#	—	PLAT or the closest approximation	*	#	#	#
	RR	*	*	—	*	*	#	*	#
	I:E	*	#	—	*	#	#	#	#
	T _{slope}	#	*	—	*	*	*	*	*
	PEEP	*	*	—	*	*	*	*	#
PCV-VG	V _t	*	*	V _{ti} measurement or the closest approximation	—	#	#	*	#
	RR	*	*	*	—	*	#	*	#
	I:E	*	#	*	—	#	#	#	#
	T _{slope}	#	*	*	—	*	*	*	*
	PEEP	*	*	*	—	*	*	*	#
	P _{limit}	*	*	#	—	#	#	*	#

* In the event that the previous ventilation mode and the current one share some parameter values, the parameter setting remains unchanged.

For the parameters that are not shared by the previous ventilation mode and the current one, the most recent settings of the parameters apply.

CURRENT VENTILATION MODE & AFFECTED PARAMETERS		PREVIOUS VENTILATION MODE							
		VCV	SIMV-VC	PCV	PCV-VG	SIMV-PC	CPAP/PS	SIMV-VG	APRV
SIMV-PC	P_{insp}	PLAT or 80% of PEAK or the closest approximation	#	*	PLAT or PEAK or the closest approximation	—	#	#	#
	RR	*	*	*	*	—	#	*	#
	T_{insp}	#	*	#	#	—	#	*	#
	ΔP_{supp}	#	*	#	#	—	*	*	#
	F-Trig/P-Trig	#	*	#	#	—	*	*	#
	PEEP	*	*	*	*	—	*	*	#
	Exp%	#	*	#	#	—	*	*	#
	Trig Window	#	*	#	#	—	#	*	#
	T_{slope}	#	*	*	*	—	*	*	*
CPAP/PS	Min RR	#	#	#	#	#	—	#	#
	ΔP_{supp}	#	*	#	#	*	—	*	#
	F-Trig/P-Trig	#	*	#	#	*	—	*	#
	PEEP	*	*	*	*	*	—	*	#
	Exp%	#	*	#	#	*	—	*	#
	Apnea I:E or Apnea Ti	#	#	#	#	#	—	#	#
	ΔP_{apnea}	#	#	#	#	#	—	#	#
	T_{slope}	#	*	*	*	*	—	*	*

* In the event that the previous ventilation mode and the current one share some parameter values, the parameter setting remains unchanged.

For the parameters that are not shared by the previous ventilation mode and the current one, the most recent settings of the parameters apply.

CURRENT VENTILATION MODE & AFFECTED PARAMETERS		PREVIOUS VENTILATION MODE							
		VCV	SIMV-VC	PCV	PCV-VG	SIMV-PC	CPAP/PS	SIMV-VG	APRV
SIMV-VG	RR	*	*	*	*	*	#	—	#
	Tinsp	#	*	#	#	*	#	—	#
	ΔPsupp	#	*	#	#	*	*	—	#
	F-Trig/P-Trig	#	*	#	#	*	*	—	#
	PEEP	*	*	*	*	*	*	—	#
	Exp%	#	*	#	#	*	*	—	#
	Trig Window	#	*	#	#	*	#	—	#
	Vt	*	*	Vt measurement or the closest approximation	*	#	#	—	#
	Plimit	*	*	#	*	#	#	—	#
Tslope	#	*	*	*	*	*	—	*	
APRV	Phigh	#	#	#	#	#	#	#	—
	Plow	#	#	#	#	#	#	#	—
	Thigh	#	#	#	#	#	#	#	—
	Tlow	#	#	#	#	#	#	#	—
	Tslope	#	*	*	*	*	*	*	—

* In the event that the previous ventilation mode and the current one share some parameter values, the parameter setting remains unchanged.

For the parameters that are not shared by the previous ventilation mode and the current one, the most recent settings of the parameters apply.

B.12 Constraints Among Ventilation Parameters

VENTILATION MODES	PARAMETERS	PARAMETER RELATION FORMULA
VCV	RR	$T_{insp} = \frac{60}{RR} \times \frac{I:E}{1+I:E} \geq 0.2$ $T_{exp} = \frac{60}{RR} - T_{insp} \geq 0.4$ $4 \leq RR \leq 100$
	Vt	$10 \leq \frac{Vt}{T_{insp}(1-TP)} \leq 3000$ $\frac{Vt * RR}{1000} \leq 60$ $10 \leq Vt \leq 2000$
	Plimit	Plimit \geq PEEP+5
	SIMV-VC	RR
SIMV-VC	Vt	$10 \leq \frac{Vt}{T_{insp}(1-TP)} \leq 3000$ $\frac{Vt * RR}{1000} \leq 60$ $10 \leq Vt \leq 2000$
	ΔP_{supp} (from VCV, PCV-VG)	$\Delta P_{supp} \leq P_{limit} - PEEP$ $3 \leq \Delta P_{supp} \leq 60$
	Plimit	Plimit \geq PEEP+5 Plimit \geq $\Delta P_{supp} + PEEP$
	PCV	RR
PCV	Pinsp	If Pinsp is configured: Pinsp \geq PEEP+5 5 \leq Pinsp \leq 90 If ΔP_{insp} is configured: $\Delta P_{insp} \leq 90 - PEEP$ 5 \leq $\Delta P_{insp} \leq 70$

VENTILATION MODES	PARAMETERS	PARAMETER RELATION FORMULA
PCV-VG	RR	$T_{insp} = \frac{60}{RR} \times \frac{I:E}{1+I:E} \geq 0.2$ $T_{exp} = \frac{60}{RR} - T_{insp} \geq 0.4$ $\frac{Vt * RR}{1000} \leq 60$ $4 \leq RR \leq 100$ $5 \leq Vt \leq 2000$
	Plimit	Plimit \geq PEEP+5
SIMV-PC	RR	$T_{exp} = \frac{60}{RR} - T_{insp} \geq 0.4$ $4 \leq RR \leq 100$
	ΔP_{supp}	$3 \leq \Delta P_{supp} \leq 60$
	P _{insp}	If P _{insp} is configured: P _{insp} \geq PEEP+5 5 \leq P _{insp} \leq 90 If ΔP_{insp} is configured: $\Delta P_{insp} \leq 90 - PEEP$ 5 \leq $\Delta P_{insp} \leq 70$
SIMV-VG	RR	$T_{exp} = \frac{60}{RR} - T_{insp} \geq 0.4$ $\frac{Vt * RR}{1000} \leq 60$ $4 \leq RR \leq 100$ $5 \leq Vt \leq 2000$
	ΔP_{supp} (from VCV, PCV-VG)	$\Delta P_{supp} \leq P_{limit} - PEEP$ $3 \leq \Delta P_{supp} \leq 60$
	Plimit	Plimit \geq PEEP+5 Plimit \geq $\Delta P_{supp} + PEEP$

This page intentionally left blank.

C.0 ***Operating Principles***

Pneumatic Diagram	C-2
Electric System Structure	C-6

C.1 Pneumatic Diagram

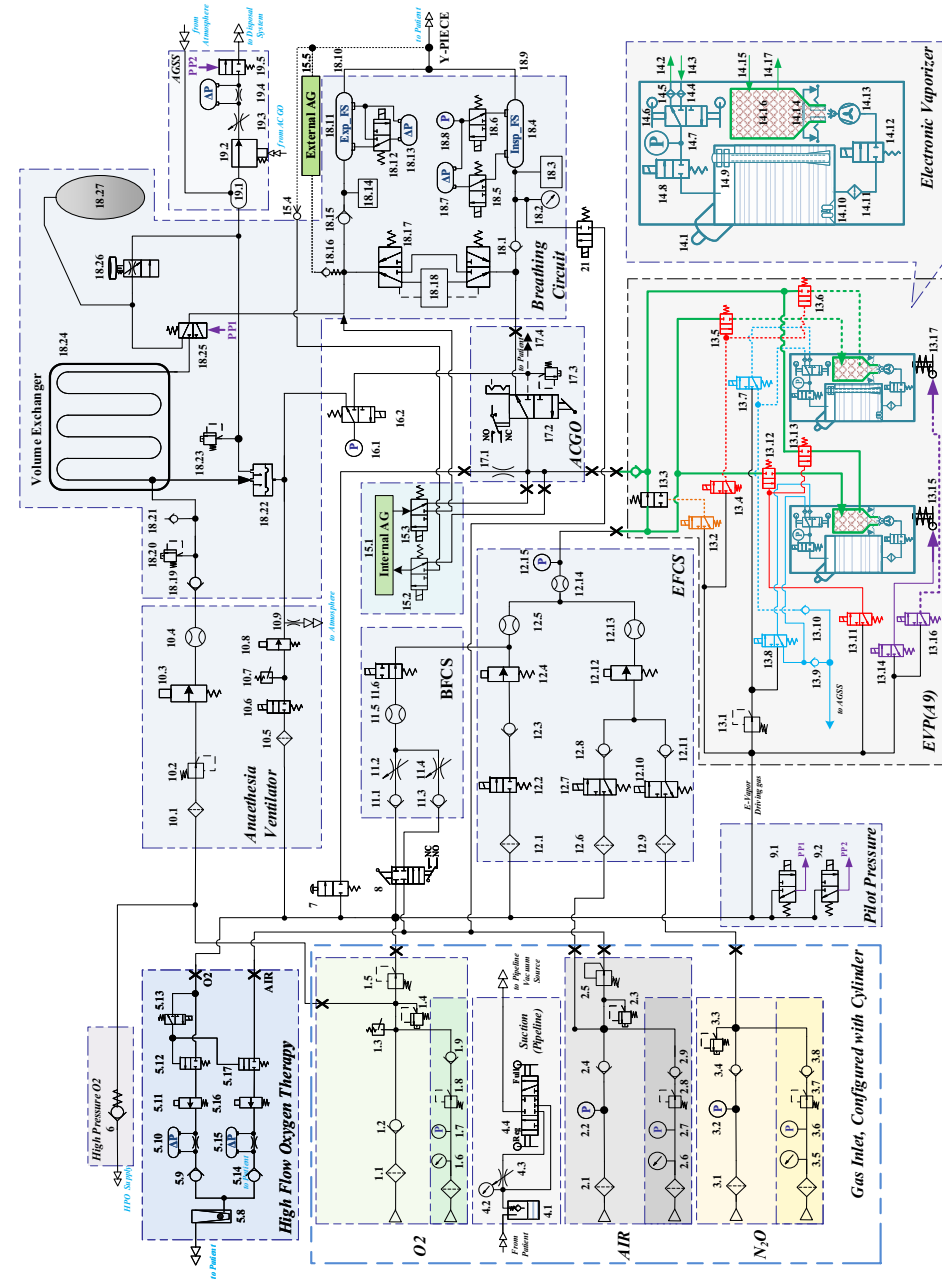

Figure C-1 Pneumatic Diagram

SERIAL NO.	MODULE	SERIAL NO.	MODULE	SERIAL NO.	MODULE
1.1	Filter	10.7	Pressure Switch	14.12	Normally-closed switch valve
1.2	Check Valve	10.8	Proportional Valve	14.13	Spraying control valve
1.3	Pressure Switch	10.9	Flow Restrictor	14.14	Infrared counter
1.4	Pressure Relief Valve	11.1	Check Valve	14.15	Fresh Gas Inlet
1.5	Pressure Regulating Valve	11.2	O2 Needle Valve	14.16	Anesthetic mixing chamber
1.6	Cylinder Pressure Gauge	11.3	Check Valve	14.17	Mixed gas outlet
1.7	Electronic Pressure Sensor of Cylinder	11.4	Air Needle Valve	15.1	Internal AG
1.8	Pressure Regulating Valve of Cylinder	11.5	Float Flowmeter (0-15LPM)	15.2	2/3 Switch-Over Valve
1.9	Check Valve of Cylinder	11.6	Normally-Open Switch Valve	15.3	2/3 Switch-Over Valve
1.12	Electronic Pressure Sensor of Pipeline	12.1	Filter	15.4	Self-sealing Sampling Tube
2.1	Filter	12.2	Normally-Closed Switch Valve	15.5	External AG
2.2	Electronic Pressure Sensor of Pipeline	12.3	Check Valve	16.1	Pressure Sensor
2.3	Pressure Relief Valve	12.4	Proportional Valve	16.2	2/3 Switch-Over Valve
2.4	Check Valve	12.5	Flow Sensor	17.1	Flow Restrictor
2.5	Pressure Regulating Valve	12.6	Filter	17.2	ACGO Switch
2.6	Cylinder Pressure Gauge	12.7	2/3 Switch-Over Valve	17.3	11 kPa Pressure Relief Valve
2.7	Electronic Pressure Sensor of Cylinder	12.8	Check Valve	17.4	ACGO Port
2.8	Pressure Regulating Valve of Cylinder	12.9	Filter	18.1	Check Valve
2.9	Check Valve	12.10	2/3 Switch-Over Valve	18.2	Airway Pressure Gauge
3.1	Filter	12.11	Check Valve	18.3	O2 Sensor
3.2	Electronic Pressure Sensor of Pipeline	12.12	Proportional Valve	18.4	Differential Pressure Gauge of Inspiration
3.3	Pressure Relief Valve	12.13	Flow Sensor	18.5	2/3 Switch-Over Valve
3.4	Check Valve	12.14	Flow Sensor	18.6	2/3 Switch-Over Valve
3.5	Cylinder Pressure Gauge	12.15	Pressure Sensor	18.7	Inspiration Flow Sensor
3.6	Electronic Pressure Sensor of Cylinder	13.1	Pressure Regulating Valve	18.8	Pressure Sensor

3.7	Pressure Regulating Valve of Cylinder	13.2	2/3 Switch-Over Valve	18.9	Inspiratory Port
3.8	Check Valve	13.3	Normally Opened Valve	18.10	Expiratory Port
4.1	Overfill Protector	13.4	2/3 Switch-Over Valve	18.11	Differential Pressure Gauge of Expiration
4.2	Negative Pressure Gauge	13.5	Normally Closed Valve	18.12	2/3 Switch-Over Valve
4.3	Negative Pressure Regulating Switch	13.6	Normally Closed Valve	18.13	Expiration Flow Sensor
4.4	Mode Selector Switch	13.7	2/3 Switch-Over Valve	18.14	Watertrap
5.8	Float Flowmeter(0-60LPM)	13.8	2/3 Switch-Over Valve	18.15	Check Valve
5.9	Check Valve	13.9	Check Valve	18.16	Self-Sealing Sampling Tube
5.10	Differential Pressure Gauge	13.10	Check Valve	18.17	Bypass
5.11	Proportional Valve	13.11	2/3 Switch-Over Valve	18.18	CO2 Absorber Canister
5.12	Pilot Normally Closed Valve	13.12	Normally Closed Valve	18.19	Check Valve
5.13	Pilot 2/3 Switch-Over Valve	13.13	Normally Closed Valve	18.20	11kPa Pressure Relief Valve
5.14	Check Valve	13.14	2/3 Switch-Over Valve	18.21	Check Valve
5.15	Differential Pressure Gauge	13.15	Pneumatic Self-Lock Valve	18.22	Expiratory Valve
5.16	Proportional Valve	13.16	2/3 Switch-Over Valve	18.23	1kPa Pressure Relief Valve
5.17	Pilot Normally Closed Valve	13.17	Pneumatic Self-Lock Valve	18.24	Volume Exchanger (VE)
6	High-Pressure O2 Output	14.1	Filling hole	18.25	Manual/Auto Switch Valve
7	O2 Flush	14.2	Driving gas outlet	18.26	APL Valve
8	System Switch	14.3	Driving gas inlet	18.27	Manual Bag
9.1	Pilot-Operated Valve of Manual/Auto Switch	14.4	Filter	19.1	Gas Reservoir
9.2	Pilot-Operated Valve of AGSS On/Off	14.5	Filter	19.2	Waste Gas Discharging Y-Piece
10.1	Filter	14.6	Switch-cover-linked pressure supply and relief valve	19.3	Negative Pressure Regulating Valve
10.2	Pressure Regulating Valve	14.7	Pressure sensor	19.4	Differential Negative Pressure Gauge
10.3	Proportional Valve	14.8	Normally-closed switch valve	19.5	Pilot-Operated AGSS Valve
10.4	Flow Sensor	14.9	Capacitive liquid level sensor	21	Normally-Closed Switch Valve

10.5	Filter	14.10	Ultrasonic liquid level sensor	/	/
10.6	Normally-Closed Switch Valve	14.11	Filter	/	/

The pneumatic system of the anesthesia system is composed of six parts: the anesthetic gas delivery system, the anesthetic gas delivery equipment (vaporizer), the anesthetic ventilator, the breathing system, the negative pressure suction system, and the Anesthetic Gas Scavenging System (AGSS).

The pneumatic circuit of the anesthetic gas delivery system is used to generate the mixed agent (fresh gas), with O₂, N₂O and Air as the input and the mixed agent (that is, fresh gas), the auxiliary O₂ supply gas, and the O₂ flush gas among others as the output.

The anesthetic gas delivery equipment (vaporizer) provides concentration-controlled anesthetic gas vapor. Isoflurane, Sevoflurane and Desflurane agents are supported.

The pneumatic circuit of the anesthetic ventilator serves to drive the respiration process of patients.

The breathing system provides a closed loop for the anesthetic gas. The CO₂ in the patient's exhaled gas is absorbed in the inspiration phase, so that the exhaled gas can be recycled for inhalation to ensure the temperature, humidity and other conditions of the gas. The breathing system has two modes available: the manual ventilation and the automatic ventilation, controlled by the manual/auto ventilation switch. Meanwhile, the system also outputs corresponding electrical signals to update the Control Board on its own status.

The Anesthetic Gas Scavenging System (AGSS) is composed of the AGSS delivery system, the AGSS absorption system and the AGSS disposal system, with the waste gas discharged from the anesthesia system outlet as the input. Its output is channeled to the facility's disposal system (AGSS disposal system).

C.2 Electric System Structure

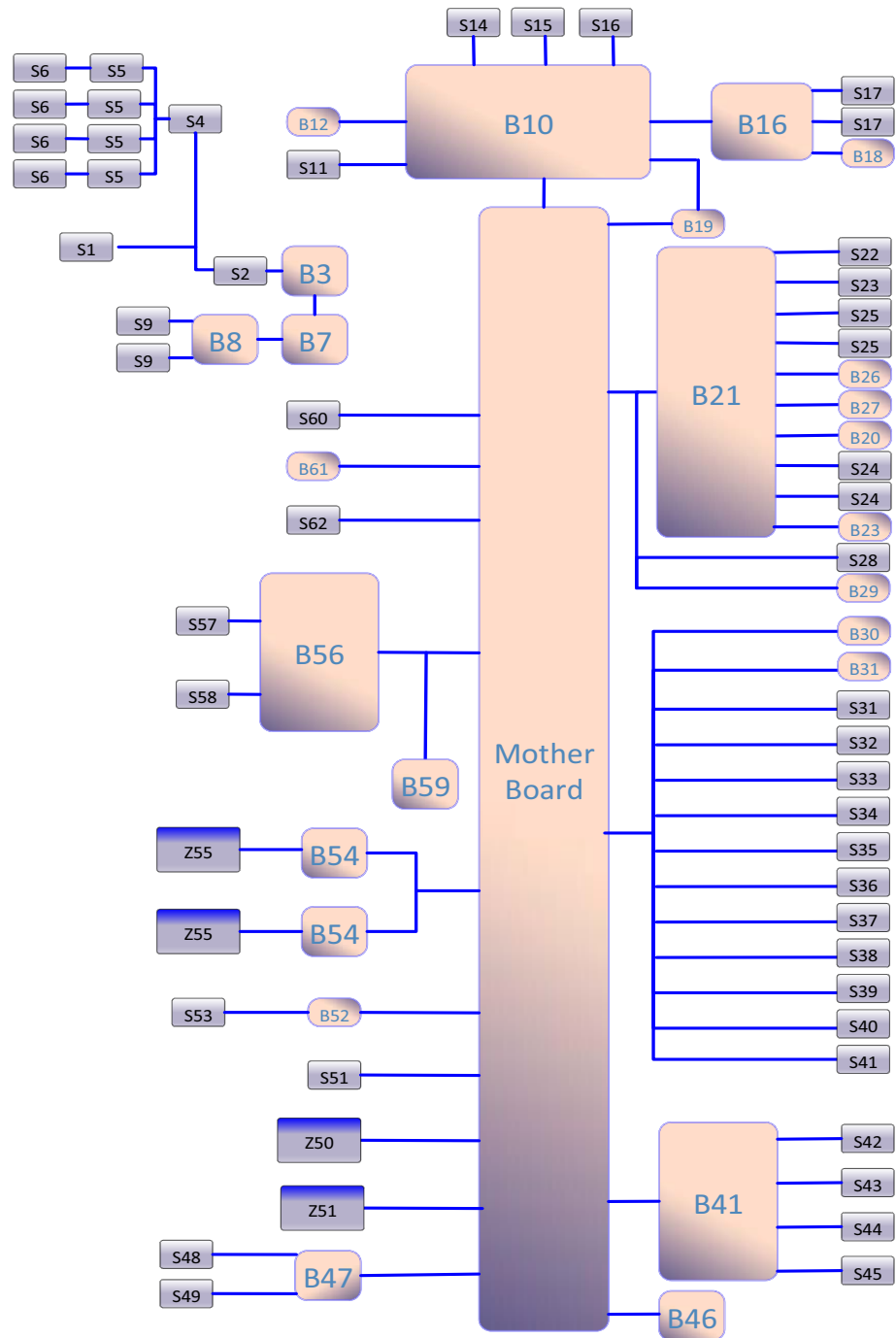

Figure C-2 Electric System Structure (Main Unit)

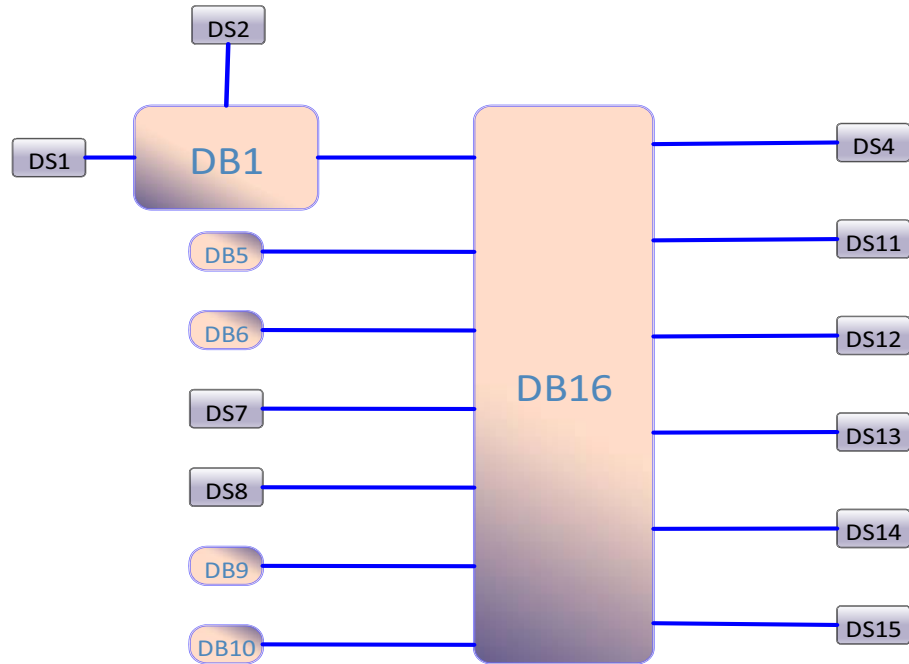

Figure C-3 Electric System Structure (Vaporizer)

SERIAL NO.	DESCRIPTION	SERIAL NO.	DESCRIPTION
S1	AC input socket	S32	O ₂ sensor
S2	Main input fuse	S33	CO ₂ absorber canister switch
B3	AC-DC power panel	S34	ACGO switch
S4	Main auxiliary output circuit breaker	S35	Warmer module
S5	Auxiliary output circuit breaker	S36	Auto/Manual valve
S6	Auxiliary outlet	S37	VE switch
B7	DC-DC power panel	S38	Manual/Auto switch
B8	Battery adapter	S39	Ventilator pneumatic block
S9	Lead-acid cell	S40	Ventilator flow sensor
B10	Control board	S41	O ₂ concentration calibration valve
S11	Speaker	B41	Electronic Flowmeter Board
B12	Alarm LED board	S42	Flow sensor
S14	Touch screen	S43	Proportional valve
S15	Display	S44	Two-way valve
S16	IOT module	S45	Y-piece
B16	Key control board	B46	Monitor module board
S17	Electronic flowmeter encoder	B47	Sensor connector board
B18	Main unit encoder board	S48	Zero Y-piece

B19	External interface board	S49	Intrapulmonary pressure switching 3-way valve
B21	Small screen control board	Z50	Card cage module
S22	Small screen	S51	AG switch 3-way valve
S23	Segment code screen	Z51	AG module
S25	HFNC encoder	B52	AGSS interface board
B26	Standby flowmeter switchboard	S53	AGSS pneumatic block
B27	Power indicator board	B54	Vaporizer interface board
B20	EFCS switchboard	Z55	Vaporizer module
B23	HFNC keyboard	B56	HFNC control board
S24	EFCS electromagnet	S57	Proportional valve
S28	System switch	S58	Two-way valve
B29	Standby flowmeter backlight	B59	HFNC flowmeter backlight
B30	APL valve indicator board	S60	Pressure switch of O ₂ supply inlet
B31	Soda lime canister light board	B61	Pipelined gas supply sensor board
S31	Circle switch	S62	Gas supply sensor of cylinder
DB1	Vaporizer and main unit interface board	DB9	Vaporizer infrared receiver
DS1	Vaporizer oil injector	DB10	Vaporizer infrared emitter
DS2	Vaporizer heating module	DS11	Vaporizer temperature sensor
DS4	In-position check switch	DS12	Vaporizer pressure sensor
DB5	Vaporizer backlight	DS13	Vaporizer bottom safety valve
DB6	Vaporizer status indicator	DS14	Vaporizer drug tank switch
DS7	Vaporizer continuous liquid level sensor	DS15	Cover-opening detection switch
DS8	Vaporizer ultrasonic wave sensor	DB16	Vaporizer monitor board

D.0

Abbreviations, Symbols, and Units of Measure

Abbreviations	D-2
Symbols	D-3
Units of Measure	D-3

D.1 Abbreviations

ABBREVIATIONS	DESCRIPTION
AA	anesthetic agent
ACGO	auxiliary common gas outlet
AGSS	anesthetic gas scavenging system
APL	airway pressure limit
Apnea I:E	ratio of inspiratory time to expiratory time of apnea
APRV	airway pressure release ventilation
BTPS	body temperature and pressure, saturated
C	C _{dyn}
CPAP/PS	Continuous positive airway pressure/pressure support ventilation
Cardiac Bypass Mode	cardiopulmonary bypass
Exp%	expiration trigger level
FiO ₂	Fraction of inspired oxygen
Flow	flow
F-Trig	flow trigger level
IBW	ideal body weight
I:E	ratio of inspiratory time to expiratory time
MEAN	mean pressure
Min RR	minimum respiratory rate
MV	minute volume
MVi	inspiratory minute ventilation
MVleak	minute leakage
N ₂ O	nitrous oxide
O ₂	Oxygen
P _{insp}	pressure control level of inspiration
P _{limit}	pressure limit level
PAW	airway pressure
PCV	pressure controlled ventilation
PCV-VG	pressure controlled ventilation-volume guarantee
PEAK	peak pressure
PEEP	positive end-expiratory pressure
PLAT	plateau pressure
ΔPapnea	apnea pressure
ΔP _{supp}	pressure support level
P-Trig	pressure trigger level
R	airway resistance
RR	respiratory rate
SIMV-PC	synchronized intermittent mandatory ventilation - pressure control
SIMV-VC	synchronized intermittent mandatory ventilation - volume control
SIMV-VG	synchronized intermittent mandatory ventilation - volume guarantee
SP	Spontaneous breathing

ABBREVIATIONS	DESCRIPTION
T _{insp}	time of inspiration
T _{pause}	percentage of inspiratory pause time
T _{slope}	rise time
Trig Window	trigger window
VCV	volume control ventilation
V _t	tidal volume
V _{ti}	inspiratory tidal volume

D.2 Symbols

SYMBOL	DESCRIPTION	SYMBOL	DESCRIPTION
-	minus, negative	>	greater than
%	percent	≤	less than or equal to
/	per, divide, or	≥	greater than or equal to
≈	approximately	±	plus or minus
^	power, involution	×	multiply
+	plus, positive	©	copyright
=	equal to	™	trademark
<	less than	®	registered trademark

D.3 Units of Measure

UNITS OF MEASURE	DESCRIPTION	UNITS OF MEASURE	DESCRIPTION
A	Ampere, Amp	m	meter
Ah	Amp hour	mAh	milliampere hour
bpm	breath per minute	mbar	millibar
°C	degree Celsius	mg	milligram
cc	cubic centimeter	min	minute
cm	centimeter	ml, mL	milliliter
cmH ₂ O	centimeter of water	mm	millimeter
dB	decibel	mmHg	millimeter of mercury
°F	Fahrenheit	ms	millisecond
g	gram	mV	milliVolt
hr	hour	mW	milliWatt
Hz	Hertz	ppm	part per million
hPa	hectoPascal	s, sec	second
inch	inch	V	Volt
k	kilo	VA	Volt Amp
kg	kilogram	VAC	Volts alternating current
kPa	kiloPascal	Ω	Ohm
psi	pound-force per square inch	μA	microAmp

UNITS OF MEASURE	DESCRIPTION	UNITS OF MEASURE	DESCRIPTION
L, l	liter	μV	microVolt
lb	pound	W	Watt
nm	nanometer		

Electromagnetic Compatibility

A9 anesthesia system complies with the EMC standard IEC 60601-1-2:2020.

- WARNING:** The use of unapproved accessories may diminish system performance.
- WARNING:** Use of components, accessories, probes, and cables other than those specified may result in increased emission or decreased immunity of system.
- WARNING:** A9 anesthesia system needs special precautions regarding EMC and needs to be installed and put into service according to the EMC information provided below.
- WARNING:** Use of A9 anesthesia system adjacent to or stacked with other equipment should be avoided because it could result in improper operation. If such use is necessary, A9 anesthesia system and the other equipment should be observed to verify that they are operating normally.
- WARNING:** Use of accessories, transducers and cables other than those specified or provided by the manufacturer of A9 anesthesia system could result in increased electromagnetic emissions or decreased electromagnetic immunity of A9 anesthesia system and result in improper operation.
- WARNING:** Portable RF communications equipment (including peripherals such as antenna cables and external antennas) should be used no closer than 30 cm (12 inches) to any part of A9 anesthesia system, including cables specified by the manufacturer. Otherwise, degradation of the performance of A9 anesthesia system could result.
- WARNING:** Other devices may interfere with A9 anesthesia system even though they meet the requirements of CISPR.
- WARNING:** When the input signal is below the minimum amplitude provided in technical specifications, erroneous measurements could result.
- WARNING:** Use of portable or mobile communications devices can degrade the performance of the equipment.

WARNING: A9 anesthesia system is not intended for use in residential environments and can possibly not provide adequate protection to radio reception in such environments.

If A9 anesthesia system is operated within the electromagnetic environment listed in TABLE E-2, TABLE E-3, TABLE E-4 and TABLE E-5, A9 anesthesia system will remain safe and will provide the following basic performances: tidal volume monitoring accuracy, CO₂ monitoring accuracy, O₂ monitoring accuracy, airway pressure monitoring accuracy, anesthetic gas monitoring accuracy and PEEP monitoring accuracy.

GUIDANCE AND DECLARATION - ELECTROMAGNETIC EMISSIONS

A9 anesthesia system is intended for use in the electromagnetic environment specified below. The customer or the user of A9 anesthesia system should assure that it is used in such an environment.

EMISSIONS TEST	COMPLIANCE	ELECTROMAGNETIC ENVIRONMENT-GUIDANCE
RF emissions CISPR 11	Group 1	A9 anesthesia system uses RF energy only for its internal function. Therefore, its RF emissions are very low and are not likely to cause any interference in nearby electronic equipment.
RF emissions CISPR 11	Class A	A9 anesthesia system is suitable for use in all establishments other than domestic and those directly connected to the public low-voltage power supply network that supplies buildings used for domestic purposes.
Harmonic emissions IEC 61000-3-2	Class A	
Voltage fluctuations/ flicker emissions IEC 61000-3-3	Complies	

TABLE E-1

GUIDANCE AND MINDRAY DECLARATION—ELECTROMAGNETIC IMMUNITY

A9 anesthesia system is intended for use in the electromagnetic environment specified below. The customer or the user of A9 anesthesia system should assure that it is used in such an environment.

IMMUNITY TEST	IEC 60601 TEST LEVEL	COMPLIANCE LEVEL	ELECTROMAGNETIC ENVIROMENT – GUIDANCE
Electrostatic Discharge (ESD) IEC 61000-4-2	±8 kV contact; ±2 kV, ±4 kV, ±8 kV, ±15 kV air	±8 kV contact; ±2 kV, ±4 kV, ±8 kV, ±15 kV air	Floors should be wood, concrete or ceramic tile. If floors are covered with synthetic material, the relative humidity should be at least 30%.
Electrical fast Transient / burst IEC 61000-4-4	±2 kV for power supply lines; ±1 kV for input/output lines	±2 kV for power supply lines; ±1 kV for input/output lines	Mains power quality should be that of a typical commercial or hospital environment.
Surge IEC 61000-4-5	±0,5 kV, ±1 kV line(s) to line(s); ±0,5 kV, ±1 kV, ±2 kV line(s) to earth	±0,5 kV, ±1 kV line(s) to line(s); ±0,5 kV, ±1 kV, ±2 kV line(s) to earth	Mains power quality should be that of a typical commercial or hospital environment.

TABLE E-2

Voltage dips, short interruptions and voltage variation on power supply input IEC 61000-4-11	0% U_T ; 0.5 cycle At 0°, 45°, 90°, 135°, 180°, 225°, 270° and 315° 0% U_T ; 1 cycle 70% U_T for 25/30 cycle at 0° 0% U_T ; 250/300 cycle	0% U_T ; 0.5 cycle At 0°, 45°, 90°, 135°, 180°, 225°, 270° and 315° 0% U_T ; 1 cycle 70% U_T for 25/30 cycle at 0° 0% U_T ; 250/300 cycle	Mains power quality should be that of a typical commercial or hospital environment. If you require continued operation during power mains interruptions, it is recommended that our product be powered from an uninterruptible power supply or a battery.
Power frequency magnetic field IEC 61000-4-8	30 A/m (50/60 Hz)	30 A/m (50/60 Hz)	Power frequency magnetic fields should be at levels characteristic of a typical location in a typical commercial or hospital environment.
NOTE: U_T is the A.C. mains voltage prior to application of the test level.			

TABLE E-2

GUIDANCE AND MINDRAY DECLARATION—ELECTROMAGNETIC IMMUNITY

A9 anesthesia system is intended for use in the electromagnetic environment specified below. The customer or the user of A9 anesthesia system should assure that it is used in such an environment.

IMMUNITY TEST	IEC 60601 TEST LEVEL	COMPLIANCE LEVEL	ELECTROMAGNETIC ENVIROMENT – GUIDANCE
---------------	----------------------	------------------	---------------------------------------

TABLE E-3

Conducted RF IEC 61000-4-6	3 Vrms 0.15 MHz to 80 MHz	3 Vrms 0.15 MHz to 80 MHz	Portable and mobile RF communications equipment should be used no closer to any part of A9 anesthesia system, including cables, than the recommended separation distance calculated from the equation applicable to the frequency of the transmitter. Recommended separation distance: $d = 1.2 \times \sqrt{P}$ $d = 2 \times \sqrt{P}$
	6 Vrms in ISM bands ^a between 0.15 MHz and 80 MHz	6 Vrms in ISM bands ^a between 0.15 MHz and 80 MHz	
Radiated RF IEC 61000-4-3	3 V/m 80 MHz to 2.7 GHz	3 V/m 80 MHz to 2.7 GHz	$d = 1.2 \times \sqrt{P}$ 80 MHz to 800 MHz $d = 2.3 \times \sqrt{P}$ 800 MHz to 2.7 GHz Where, P is the maximum output power rating of the transmitter in watts (W) according to the transmitter manufacturer and d is the recommended separation distance in meters (m). Field strengths from fixed RF transmitters, as determined by an electromagnetic site survey, ^b should be less than the compliance level in each frequency range. ^c Interference may occur in the vicinity of equipment marked with the following symbol: 

NOTE: At 80 MHz and 800 MHz, the higher frequency range applies.

NOTE: These guidelines may not apply in all situations. Electromagnetic propagation is affected by absorption and reflection from structures, objects and people.

^a The ISM (industrial, scientific, and medical) bands between 150 kHz and 80 MHz are 6.765 MHz to 6.795 MHz; 13.553 MHz to 13.567 MHz; 26.957 MHz to 27.283 MHz; and 40.66 MHz to 40.70 MHz. The amateur radio bands between 0.15 MHz and 80 MHz are 1.8 MHz to 2.0 MHz, 3.5 MHz to 4.0 MHz, 5.3 MHz to 5.4 MHz, 7 MHz to 7.3 MHz, 10.1 MHz to 10.15 MHz, 14 MHz to 14.2 MHz, 18.07 MHz to 18.17 MHz, 21.0 MHz to 21.4 MHz, 24.89 MHz to 24.99 MHz, 28.0 MHz to 29.7 MHz and 50.0 MHz to 54.0 MHz.

^b Field strengths from fixed transmitters, such as base stations for radio (cellular/cordless) telephones and land mobile radios, amateur radio, AM and FM radio broadcast and TV broadcast cannot be predicted theoretically with accuracy. To assess the electromagnetic environment due to fixed RF transmitters, an electromagnetic site survey should be considered. If the measured field strength in the location in which the device is used exceeds the applicable RF compliance level above, the device should be observed to verify normal operation. If abnormal performance is observed, additional measures may be necessary, such as re-orienting or relocating the device.

^c Over the frequency ranges 150 kHz to 80 MHz, field strengths should be less than 3V/m.

TABLE E-3

GUIDANCE AND MINDRAY DECLARATION—ELECTROMAGNETIC IMMUNITY

A9 anesthesia system is intended for use in the electromagnetic environment specified below. The customer or the user of A9 anesthesia system should assure that it is used in such an environment.

IMMUNITY TEST	IEC 60601 TEST LEVEL	COMPLIANCE LEVEL	ELECTROMAGNETIC ENVIRONMENT – GUIDANCE
Proximity magnetic fields IEC 61000-4-39	65 A/m 134.2 kHz Pulse modulation 2.1 kHz	65 A/m 134.2 kHz Pulse modulation 2.1 kHz	/
	7.5 A/m 13.56 MHz Pulse modulation 50 kHz	7.5 A/m 13.56 MHz Pulse modulation 50 kHz	

TABLE E-4

RECOMMENDED SEPARATION DISTANCES BETWEEN PORTABLE AND MOBILE RF COMMUNICATIONS EQUIPMENT AND A9 ANESTHESIA SYSTEM

A9 anesthesia system is intended for use in an electromagnetic environment in which radiated RF disturbances are controlled. The customer or the user of A9 anesthesia system can help prevent electromagnetic interference by maintaining a minimum distance between portable and mobile RF communications equipment (transmitters) and the A9 anesthesia system as recommended below, according to the maximum output power of the communications equipment. Portable and mobile radio communications equipment (e.g. two-way radio, cellular/cordless telephones and similar equipment) should be used no closer to any part of this system, including cables, than determined according to the following method:

TEST FREQUENCY (MHZ)	BAND (MHZ)	SERVICE	MODULATION	MAXIMUM POWER (W)	DISTANCE (M)	IMMUNITY TEST LEVEL (V/M)
385	380 - 390	TETRA 400	Pulse modulation 18 Hz	1.8	0.3	27
450	430 -470	GMRS 460 FRS 460	FM ±5 kHz deviation 1 kHz sine	2	0.3	28
710	704 - 787	LTE Band 13,17	Pulse modulation 217 Hz	0.2	0.3	9
745						
780						

TABLE E-5

810	800 - 960	GSM 800/900, tetra 800, iDEN 820, CDMA 850, LTE Band 5	Pulse modulation 18 Hz	2	0.3	28
870						
930						
1720	1700 -1990	GSM 1800, CDMA 1900, GSM 1900, DECT, LTE Band 1, 3,4,25,UMTS	Pulse modulation 217 Hz	2	0.3	28
1845						
1970						
2450	2400 -2570	Bluetooth, WLAN, 802.11 b/g/n, RFID 2450, LTE Band 7	Pulse modulation 217 Hz	2	0.3	28
5240						
5500	5100 -5800	WLAN, 802.11 a/n	Pulse modulation 217 Hz	0.2	0.3	9
5785						

TABLE E-5

RECOMMENDED SEPARATION DISTANCES BETWEEN PORTABLE AND MOBILE RF COMMUNICATION DEVICE AND A9 ANESTHESIA SYSTEM

A9 anesthesia system is intended for use in an electromagnetic environment in which radiated RF disturbance are controlled. The customer or the user of A9 anesthesia system can help prevent electromagnetic interference by maintaining a minimum distance between portable and mobile RF communication equipment (transmitters) and system as recommended below, according to the maximum output power of the communication equipment.

Rated Maximum Output power of Transmitter (W)	Separation Distance According to Frequency of Transmitter			
	150 kHz to 80 MHz Out ISM bands	150 kHz to 80 MHz in ISM bands	80 MHz to 800 MHz	800 MHz to 2.7 GHz
	$d=1.2 \sqrt{P}$	$d=2 \sqrt{P}$	$d=1.2 \sqrt{P}$	$d=2.3 \sqrt{P}$
0.01	0.12	0.20	0.12	0.23
0.1	0.38	0.64	0.38	0.73
1	1.2	2.0	1.2	2.3
10	3.8	6.4	3.8	7.3

TABLE E-6

100	12	20	12	23
-----	----	----	----	----

For transmitters at a maximum output power not listed above, the recommended separation distanced in meters (m) can be determined using the equation applicable to the frequency of the transmitter, where P is the maximum output power rating of the transmitter in watts (W) according to the transmitter manufacturer.

NOTE: At 80 MHz and 800 MHz, the higher frequency range applies.

NOTE: These guidelines may not apply in all situations. Electromagnetic propagation is affected by absorption and reflection from structures, objects and people.

TABLE E-6

NO.	NAME	CABLE LENGTH(m)	Cable Shielded (Y/N)
1	Anesthesia System Power input	5.0	N
2	BIS cable	1.3	Y
3	BIS cable	2.7	Y
4	NM13101 cable	3.0	Y
5	NM13401 cable	0.4	N
6	NM13701 cable	0.3	N
7	Mainstream CO ₂ module cable	< 3.0	Y

TABLE E-7

ANESTHESIA SYSTEM'S ESSENTIAL PERFORMANCE		ESSENTIAL PERFORMANCE TESTED DURING EMC IMMUNITY TESTS	CRITERIA DURING EMC IMMUNITY
1. Oxygen flow under all conditions except the failure of the oxygen supply (pipeline or cylinder) to the anaesthetic workstation or the generation of a technical alarm condition	1.1 Oxygen supply failure protection device	1.1.1 Oxygen supply failure protection device	No false O ₂ supply failure alarm shall be activated and the fresh gas flow shall be maintained when the O ₂ supply pressure is within the rated input pressure range.
	1.2 Interruption of the electrical power supply	1.2.1 Power management	The anesthesia system can run on AC power supply and battery supply, and Battery in Use alarm of low priority shall be indicated only in case of AC power supply failure. The ventilation shall be maintained, and the control and monitoring accuracy shall meet the requirements of the specification. The fresh gas flow shall be maintained, and the accuracy shall meet the requirements of the specification.
	1.3 Oxygen flush	/	/

TABLE E-8

ANESTHESIA SYSTEM'S ESSENTIAL PERFORMANCE		ESSENTIAL PERFORMANCE TESTED DURING EMC IMMUNITY TESTS	CRITERIA DURING EMC IMMUNITY
2. Delivery of a non-hypoxic gas mixture to the patient or generation of a technical alarm condition	2.1 Alarm condition for power supply failure	/	/
	2.2 Internal electrical power source	2.2.1 Battery power supply	The residual capacity of battery power can be indicated normally when battery power works.
	2.3 Protection against hazardous output	2.3.1 Control and monitoring accuracy	Control accuracy: Tidal volume: 30±10 ml Breath rate: 30± 1 bpm Monitoring accuracy: Tidal volume: 30±10 ml Breath rate: 30± 1 bpm Airway pressure: ±2.0 cmH ₂ O or ±4% of the measured value, whichever is greater
	2.4 Reverse flow and cross-flow protection device	/	/
	2.5 Gas mixers	2.5.1 Gas mixers	Accuracy: 0.2±0.1 L/min
	2.6 Oxygen flush	/	/
3. Non-delivery of excessive concentrations of a volatile anaesthetic agent or generation of a technical alarm condition	3.1 Delivered vapour concentration	/	/
	3.2 Anaesthetic agent monitoring equipment	3.2.1 Anaesthetic agent monitoring equipment	Accuracy (%): CO ₂ : 0 ± 0.1 vol.% N ₂ O: 0 ± 2 vol.% O ₂ : 21 ± 1 vol.% DES: 0 ± 0.15 vol.% (only applicable for equipping with Desflurane electrical vaporizer)
4. Airway pressure monitoring and associated alarm	4.1 Airway pressure monitoring equipment	/	/
5. Measurement accuracy and gas reading alarm condition or generation of a technical alarm condition (AG module)	5.1 Measurement accuracy	/	/
	5.2 Alarm condition priority	/	/
	5.3 Supply failure technical alarm condition	/	/

TABLE E-8

F.0

Preparation for Malignant Hyperthermia Susceptible Patients

Malignant Hyperthermia Causes, Effects and Treatment	F-2
Malignant Hyperthermia Washout	F-2
Washout Procedure for Malignant Hyperthermia Susceptible Patients with Anesthesia Delivery Systems	F-2
References.....	F-4

F.1 Malignant Hyperthermia Causes, Effects and Treatment

Malignant Hyperthermia (MH) is an uncommon inherited, life-threatening pharmacokinetic skeletal muscle disorder involving the dysregulated myoplasmic Ca^{2+} , hypercontracture, and hypermetabolism. Triggering factors include exposure to potent volatile anesthetic gases and depolarizing muscle relaxants.¹⁻⁴

The disorder is characterized by skeletal muscle hypermetabolism, which is related to an uncontrolled release of calcium from skeletal muscle sarcoplasmic reticulum. These results in increased carbon dioxide production, increased core temperature, and generalized muscle rigidity with resultant rhabdomyolysis, acidosis, and hyperkalemia. If untreated, MH may lead to cardiac arrhythmia, multiorgan system failure, and death.^{2,3}

MH has had a reported mortality rate decrease from 70%-80% to less than 5% if preventive measures and effective management are adopted.² The early therapy requires immediate discontinuation of all the triggering agents, adequate oxygenation and ventilation, institution of aggressive cooling measures, administration of dantrolene sodium, and appropriate treatment for hyperkalemia. Ultimately, the only effective treatment for an MH crisis is the intravenous administration of dantrolene sodium and supportive therapy to combat the symptoms.^{1,2}

F.2 Malignant Hyperthermia Washout

To prevent MH in susceptible patients or to treat MH occurring during inhalational anesthesia, all inhalational anesthetics should be removed from the anesthesia machine. Avoidance of potent vapor anesthetics, such as Sevoflurane, Isoflurane or Desflurane,⁴ in patient cases is more challenging, based on the complex newer generation anesthesia machines and breathing circuits which retain anesthetic vapors long after discontinuation. The ultimate goal is to eliminate the residual anesthetic vapor concentration within the breathing system. The recommended instructions for clearing residual anesthetic gases include removal or disabling of vaporizers, flushing the machine using the ventilator with a fresh gas flow rate more than 10 L/min, replacement of the carbon dioxide absorbent and anesthesia circuit.^{1,3}

F.3 Washout Procedure for Malignant Hyperthermia Susceptible Patients with Anesthesia Delivery Systems

The minimum inhaled concentration for triggering an episode of MH is unknown. Studies assumed a trace concentration of inhalational anesthetics below 5 ppm to be safe.⁵⁻⁸ The following steps are recommended to prepare a anesthesia system for an MH-susceptible patient.

1. Turn off and remove all the vaporizers from the anesthesia system to prevent their inadvertent use.
2. Remove the carbon dioxide absorbent, breathing bag and the entire patient breathing circuit, filters, sampling line, water trap, and airway adapter and replace with new circuit and parts, connect a new breathing bag or test lung to the patient Y-piece.
3. Ventilate for a minimum of 40 minutes using mechanical ventilation with the following settings, 700 ml tidal volume, I:E ratio of 1:2, 12 breaths/minute, PEEP of 0 cmH_2O , and oxygen fresh gas flow rate of 15 L/min.
4. Upon completion of the 40 minute flush, remove the patient breathing circuit. Replace with a new patient breathing circuit, including bag and new carbon dioxide absorbent. Perform the pre-operative checkout.

- Maintain the oxygen fresh gas flow rate of 15 L/min throughout the case to functionally create a non-rebreathing system and minimize rebound of volatile concentration at low fresh gas flow rates.

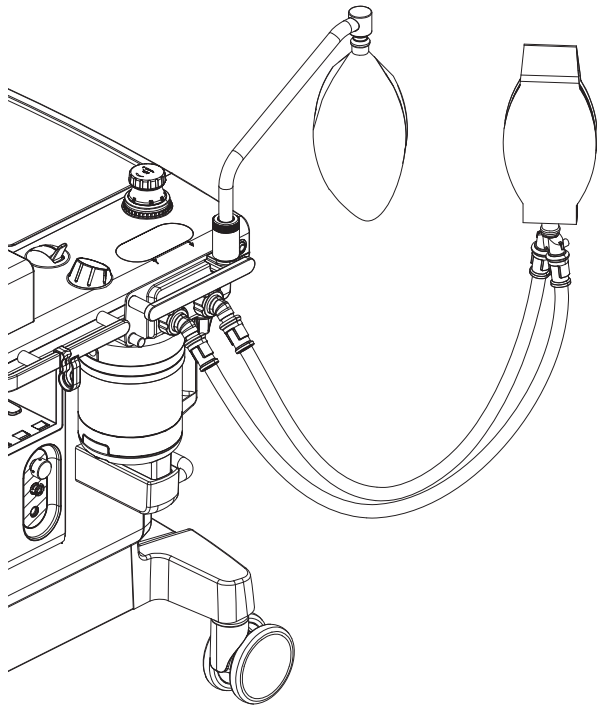
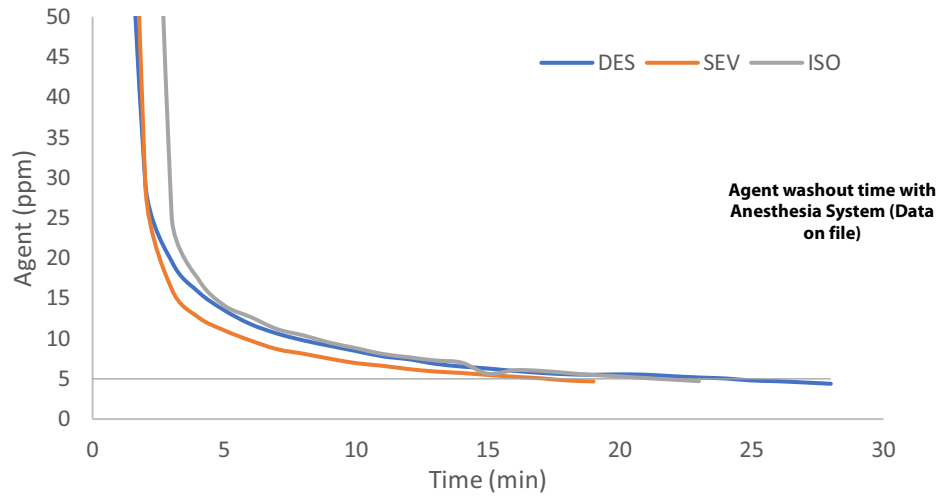

FIGURE F-1 Washout Procedure for Malignant Hyperthermia Susceptible Patients

The following guidelines are recommended by the Malignant Hyperthermia Association of the United States (MHAUS)*

Preparation of Anesthesia Workstations to Anesthetize MH Susceptible Patients

Recommendations (4 alternatives):

1. Flush and prepare workstation according to manufacturer's recommendations or published studies; this may take 10 to >90 minutes. Most studies also physically disconnect vaporizers from the workstation; use a new, disposable breathing circuit; and replace the carbon dioxide absorbent. During the case, fresh gas flow should be kept at 10 liters per minute to avoid "rebound phenomenon" (increased release of residual volatile anesthetic agent when fresh gas flow is reduced after a set period of flushing). or
2. Use commercially available charcoal filters that have been shown to remove trace levels of volatile anesthetic agents within 10 minutes of application, without additional preparation. These filters may have to be regularly replaced during the anesthetic.⁺⁺ or
3. If available, use a dedicated "vapor free" machine for MH-susceptible patients. The machine must be regularly maintained and safety-checked. or
4. If appropriate to the institution, use an ICU ventilator that has never been exposed to volatile anesthetic agents.

For further information contact the Malignant Hyperthermia Association of the United States at <http://www.mhaus.org/>

*: Guidelines are excerpted from the MHAUS website and do not replace the indicated instructions for preparation of the anesthesia system.

⁺⁺: This method has not been tested with.

F.4 References

1. Hopkins PM. Malignant hyperthermia: pharmacology of triggering. *Br J Anaesth.* 2011 Jul; 107 (1): 48-56.
2. Kim DC. Malignant hyperthermia. *Korean J Anesthesiol.* 2012 Nov; 63 (5): 391-401.
3. Kim TW, Nemergut ME. Preparation of modern anesthesia workstations for malignant hyperthermia-susceptible patients: a review of past and present practice. *Anesthesiology.* 2011 Jan;114 (1):205-212.
4. Schuster F, Johannsen S, Schneiderbanger D, Roewer N. Evaluation of suspected malignant hyperthermia events during anesthesia. *BMC Anesthesiology* 2013, 13: 24.
5. Gunter JB, Ball S, Tan-Win S. Preparation of the Drager Fabjus anesthesia machine for the malignant -hyperthermia susceptible patient. *Anesth Analg* 2008; 107: 1936-45.
6. Reber A, Schumacher P, Urwyler A. Effects of three different types of management on the elimination kinetics of volatile anaesthetics. Implications for malignant hyperthermia treatment. *Anaesthesia* 1993; 48: 862-5.
7. Crawford MW, Prinzhausen H, Petroz GC. Accelerating the washout of inhalational anesthetics from the Drager Primus anesthetic workstation. *Anesthesiology* 2007; 106:289-94.
8. Prinzhausen H, Crawford MW, O'Rourke J, Petroz GC. Preparation of the Drager Primus anesthetic machine for malignant hyperthermia-susceptible patients. *Can J Anesth* 2006; 53: 885-90.

