

Peripherals and Communications

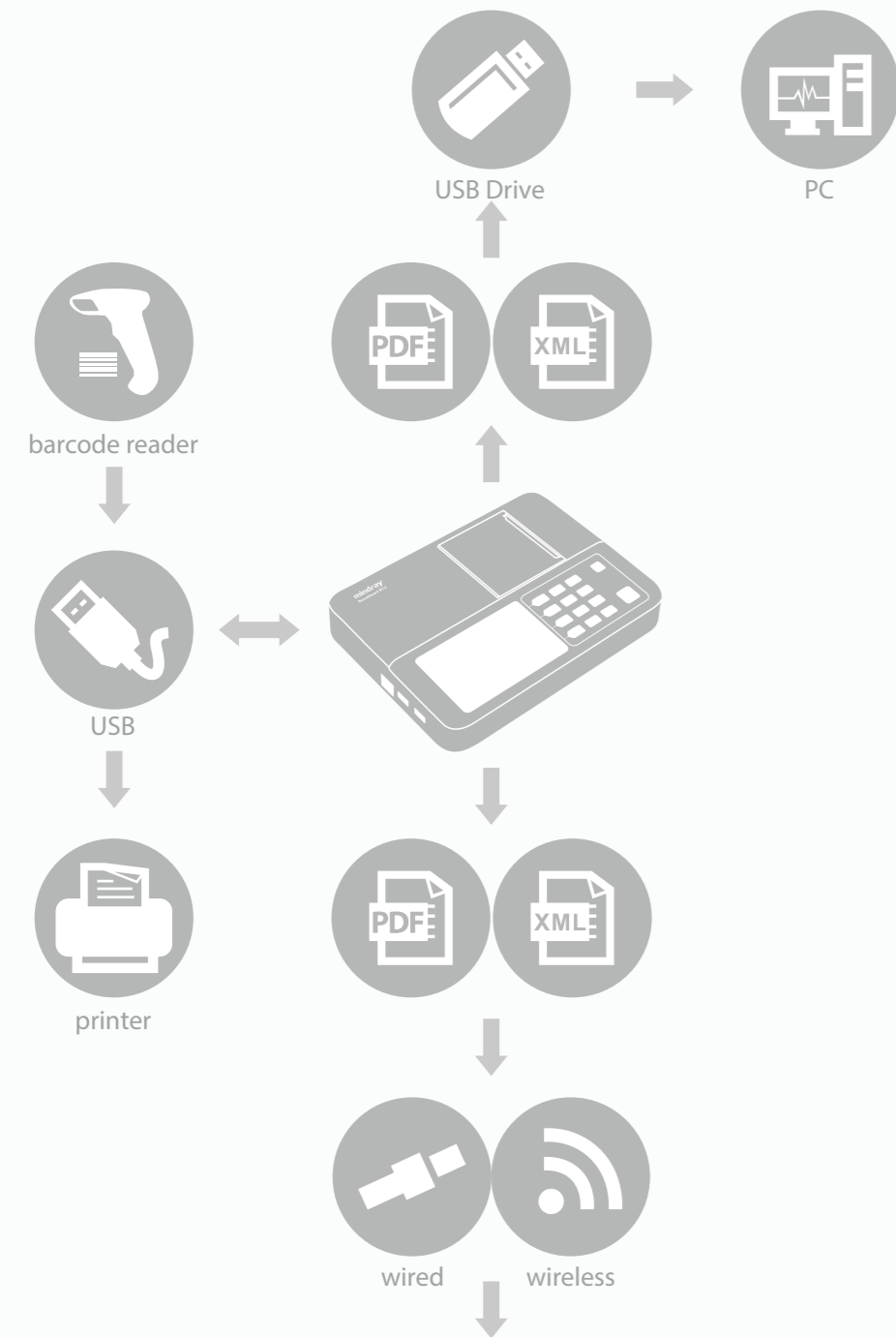

ECG Management System

BeneHeart R3

Electrocardiograph

Physical	
Height:	56 mm
Width:	260 mm
Depth:	194 mm
Weight:	1.2 Kg including battery, internal AC power supply
Processing	
Digital sampling rate:	1000 samples/second/channel
Pacer detection sampling rate:	16,000 samples/second/channel
ECG amplifier:	DC-coupled
Acquisition mode:	Pre- or post-acquisition, provide 10 seconds of instantaneous ECG acquisition
Dynamic range:	AC differential ± 10 mV, DC offset ± 600 mV
Resolution:	1 μ V/LSB
Frequency response:	-3 dB @ 0.05 to 150 Hz
Baseline drift filter:	0.05 Hz, Baseline Drift Removal (BDR)
Artifact filter:	20 Hz, 35 Hz
AC filter:	50/60 Hz
Common mode rejection:	≥ 110 dB (with AC filter switched off)
ADC:	24 bits
Input impedance:	> 50 M Ω @ 10 Hz, defibrillator protected
Time Constant:	≥ 3.2 s
Noise Level:	≤ 15 μ V
Patient leakage:	< 10 μ A
Heart rate meter:	30 to 300 BPM $\pm 10\%$ or ± 5 BPM, whichever is greater
Startup time:	≤ 5 second
Sensitivity/gain:	5, 10, 20 mm/mV, Auto
Display	
Display type:	5-inch 24-bit color, TFT LCD with LED graphics backlight
Display resolution:	800*480 pixels
Display data:	Patient ID, gender, age, heart rate, clock, battery power indicator, waveforms, lead labels, speed, gain and filter settings, warning messages, information messages, network, USB status
Power	
Power supply:	AC input (without external power adaptor) or battery operation
AC Power	
Input voltage:	100 to 240 VAC $\pm 10\%$
Input power:	60 VA
AC frequency:	50/60 Hz ± 3 Hz
Battery	
Battery type:	Rechargeable Lithium ion battery, 11.1 V, 2500 mAh
Battery capacity:	6 hours of continuous operation without recording or 500 ECGs in 2.5x4 format at 25 mm/s and 10 mm/mV
Battery charge time:	3.5 hours with power off
Writer	
Writer technology:	Thermal dot array
Writer Width:	80 mm
Writer speed:	5, 12.5, 25, 50 mm/s
Number of traces:	3 leads + 1 rhythm or 3 leads; user selectable



Writer speed accuracy:	$\pm 5\%$
Writer amplitude accuracy:	$\pm 5\%$
Writer resolution:	Horizontal 32dots/mm @ 25mm/s, Vertical 8 dots/mm
Paper type:	Thermal roll paper (20 m) or Z-fold paper (80 mm width, 200 sheets/pack)
Software	
Measurement and interpretation:	Supports the University of Glasgow 12-lead ECG analysis program for adults and pediatrics
Resting ECG mode:	Records and prints 12-lead resting ECG with 10-second duration as a standard feature
Supported patient information:	Name, patient ID, secondary ID, age, date of birth, gender, race, medication, class, V3 electrode Placement.
Internal storage:	800 ECGs in internal memory
ECG Storage format:	XML, PDF, Mindray
Multi-language support:	Supports 13 languages
Extensional Function	
Reanalyze ECG automatically after changing patient's demographics	
Connect to external printer directly (Optional)	
Upload XML or PDF reports through FTP protocol (Optional)	
Barcode scanner (Optional)	
Wifi (Optional)	
USB flash drive storage of PDF and XML outputs (Optional)	
Report Formats	
Thermal printer report formats:	4 by 2.5s (Sequential) 4 by 2.5s Compact 4 by 2.5s + 1 rhythm lead 4 by 2.5/5/7.5/10s (Simultaneous) Auto-rhythm (60-second ECG data for 1 rhythm lead) Continuous 1 or 3 channel manual rhythm
PDF report format (A4/Letter):	4 by 2.5s + 1 rhythm lead 2 by 5s 2 by 5s + 1 rhythm lead 1 by 10s
Accessories	
ECG patient cable with banana plugs, Limb Clamps, Chest Bulbs (IEC/AHA)	
ECG cable with Electrode clips (IEC/AHA)	
Country-specific power cords	
Z-fold and Roll paper	
Trolley	
Environmental Specification	
Temperature	
Operating:	0°C to 40°C
Transport/storage:	-20°C to 60°C
Humidity	
Operating:	15% to 95% RH non-condensing
Transport/storage:	10% to 95% RH non-condensing
Pressure	
Operating:	57.0 kPa to 107.4 kPa
Transport/storage:	16.0 kPa to 107.4 kPa



www.mindray.com

P/N:ENG-BeneHeart R3-210285X6P-20180601
©2018 Shenzhen Mindray Bio-Medical Electronics Co.,Ltd. All rights reserved.

mindray
healthcare within reach

BeneHeart R3

Electrocardiograph

Your Faithful Consultant for Resting ECG Diagnosis



BeneHeart R3

Electrocardiograph

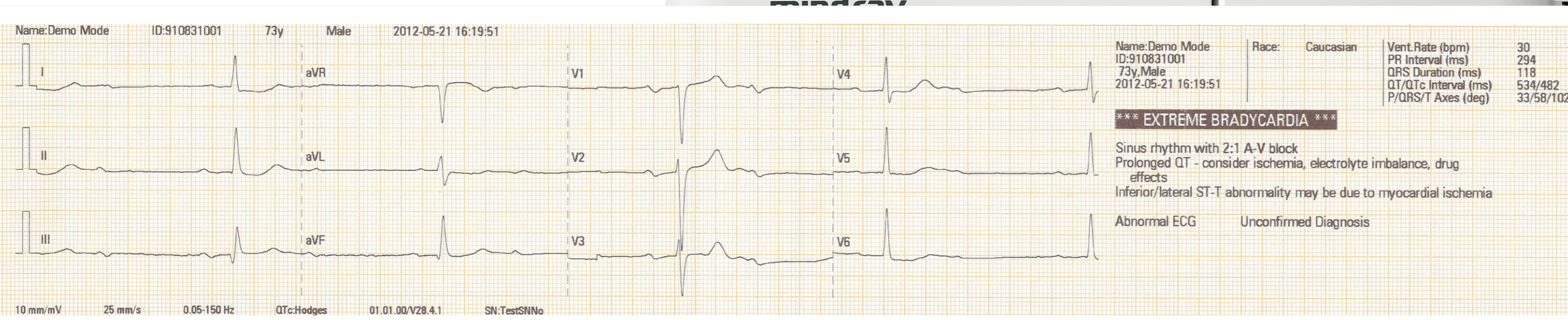

The Glasgow algorithm is the first to be based on specific variables, including age, gender, race, medication, and class in order to maximize the accuracy of the ECG interpretation.

On the report, a headline may highlight one of several "critical value warnings" to alert medical attendants of findings that need immediate attention.

For neonates and children, lead V4R is used instead of V3 to improve the diagnostic accuracy.

Reliable Analysis

BeneHeart R3 utilizes the University of Glasgow ECG analysis algorithm, one of the world-leading resting ECG interpretations with 50 years of history.

Clear Display

5-inch color screen offers the highest resolution in industry, enabling clinicians to observe real-time waveforms accurately.

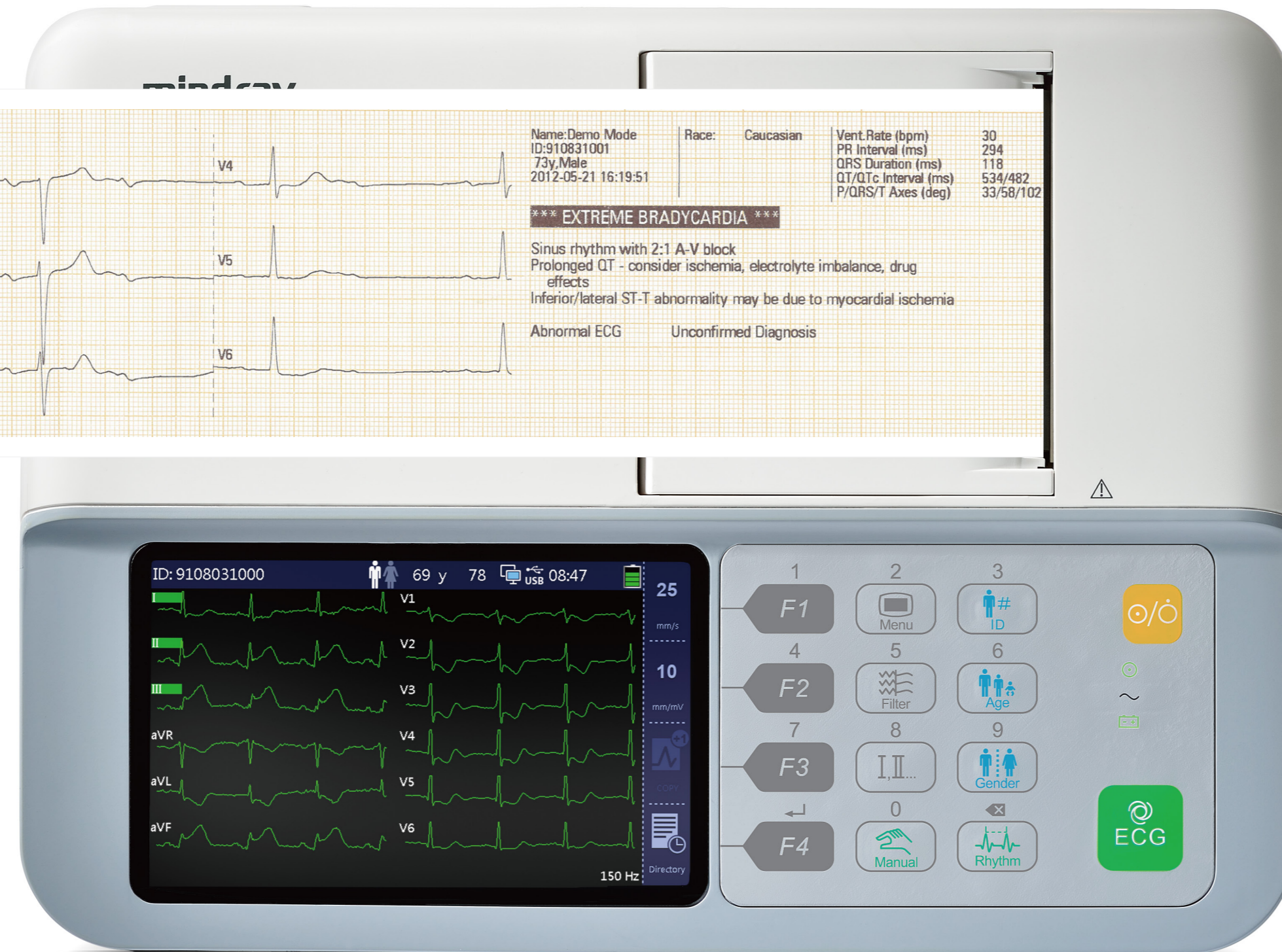

Great Mobility

The BeneHeart R3 weighs only 1.2kg with battery, easy to carry. The trolley can make BeneHeart R3 mobile to wherever it is needed.

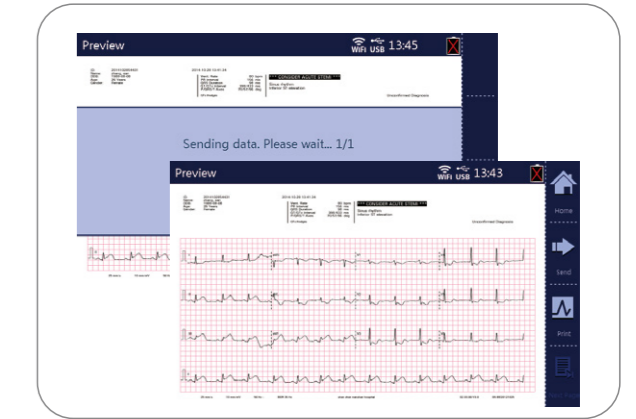

Convenient Operation

The user-friendliness of BeneHeart R3's interface provides several paper-saving features, the report preview (before printed), re-analysis (if the patient information is modified) and E-report transmission.

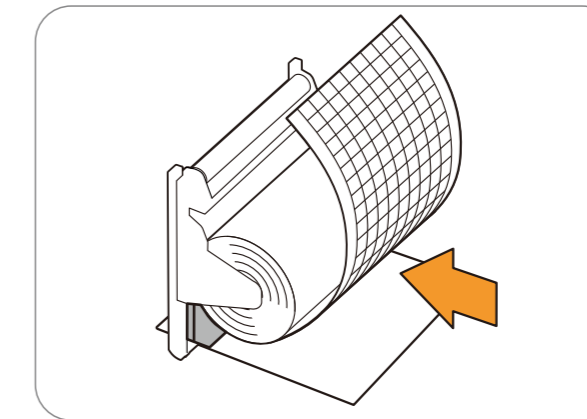

With rolling paper

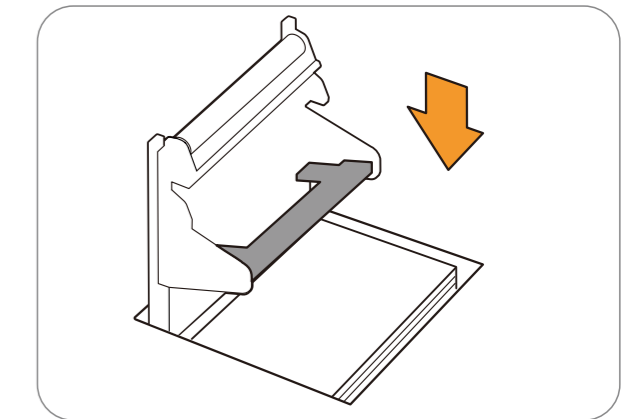

With Z-fold paper

Unique Recorder

Compatible with both rolling paper and Z-fold paper, you can easily switch between these two styles of papers without dismantling the pressure lever.