

Two-Way Continuous Transmit and Receive Focusing in Ultrasound Imaging

Thomas Jdrzejewicz¹, David Napolitano², Derek DeBusschere², Ching-Hua Chou², and Glen McLaughlin²
¹Medical Ultrasound Consultant, Austin, TX, USA, ²ZONARE Medical Systems, Inc., Mountain View, CA, USA

Abstract—Digital beamformers set the diagnostic performance limitations of well designed ultrasound systems. While there have been significant advancements in receive processing over the years, only incremental progress has been made in the transmit processing, thus imposing performance limitations in the first step of image acquisition. This paper presents a technology, ZONE Sonography, that is able to overcome many of these limitations by enabling transmit beamformation to utilize technologies that the receive side has enjoyed on traditional systems. These technologies include the ability to generate a dynamic transmit focus, dynamic transmit aperture, and dynamic transmit apodization while reducing the number of transmit/receive cycles required to adequately sample the image space. This results in improved detail resolution, contrast resolution, image uniformity, and temporal resolution. This paper establishes a figure of merit (FOM) based on the preceding attributes to compare and contrast performance tradeoffs based on an idealized and previously unrealizable platform.

Index Terms—ZONE Sonography, Dynamic Transmit Focus

I. INTRODUCTION

SINCE the early 1980s, the technical mainstay of commercial ultrasound systems has been the beamformer.

It is the front-end of every commercial ultrasound system and it plays a critical role in determining image information content and image quality. The operation and evolution of beamformers and beamformer-based systems has been extensively described in the literature [1]. Today, these systems represent the end product of a long evolution, from analog to digital, and current high performance ultrasound systems produce images with good image quality.

It is generally accepted that image quality can be defined by the following parameters[2]:

- **Detail resolution:** ability to distinguish small adjacent structures with clarity
- **Contrast resolution:** ability to differentiate a region of one echogenicity within a region of another echogenicity
- **Image uniformity:** ability to maintain comparable detail and contrast resolution throughout the field of view
- **Temporal resolution:** time required to acquire an independent image

These parameters represent an objective measure of image quality; they can be quantified and used to compare different systems.

II. BEAMFORMER DESCRIPTION AND LIMITATIONS

A generic block diagram of a typical digital beamformer-based system is shown in Figure 1. In spite of what may appear to be a simple device, a beamformer performs a large number of important functions necessary to produce an image of acceptable quality.

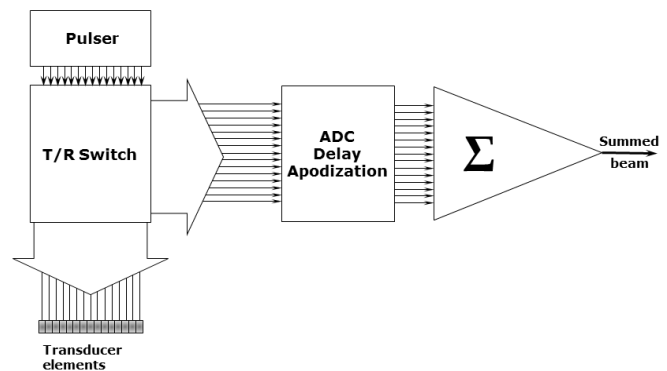

Fig. 1. Block diagram of a typical beamformer. It includes a transmit/receive switching network, analog-to-digital converters (ADC), delay circuits required for focusing and beam steering, apodization generation required for side lobe suppression, and finally a summing circuit which sums the echoes from individual transducer elements into a single beam.

The technical characteristics necessary to achieve each of the parameters in the figure of merit need to be considered: as they delineate the cause for the relative performance of each system.

- **Dynamic transmit and receive focus** on a point-by-point basis
- **Dynamic transmit and receive apodization** on a point-by-point basis
- **Simultaneous echo data collection**
- **Tissue matched echo processing** for differences in tissue and/or anatomy

Clearly these are ideals; compromises must often be made and the best that one can hope for is to approach ideal performance. As witnessed by the image quality produced by some of the high performance ultrasound systems, beamformer-based systems do a credible job of approaching some of the ideal characteristics primarily within the receive

processing path. If one examines each of these ideal characteristics, it becomes clear that fundamental beamformation theory can be in conflict with certain physical properties of the tissue, resulting in performance limitations. As will be subsequently shown, a technology is available that approaches the ideal characteristics more closely than ever before, resulting in measurable improvements in image quality.

- **Dynamic transmit and receive focus on a point by point basis.** Beamformer-based systems do a credible job of performing dynamic focusing on receive, however transmit focusing is static, i.e., a single focus per transmit pulse. The resulting echoes produced by the combined two-way acoustic field display good lateral resolution around the single point of focus, however lateral resolution degrades away from that focal point. This limitation can always be reduced if one is willing to sacrifice other image performance characteristics such as temporal resolution.
- **Dynamic transmit and receive apodization on a point-by-point basis.** Apodization, or aperture shading, is a form of spatial filtering that reduces sidelobes, thus improving contrast resolution. Beamformer-based systems utilize dynamic apodization on receive, however transmit apodization is static, resulting in a fixed filtering function being applied. Therefore, sidelobes are reduced only around the focal point. This contributes to image clutter and reduces contrast resolution away from this point.
- **Simultaneous echo data collection.** The speed of sound in tissue is a fixed physical property, assumed to be 1540 m/s, depending on the tissue type. This physical limitation prevents instantaneous echo acquisition. Beamformer processing is a serial “line-by-line” echo acquisition process and due to the Nyquist spatial sampling criterion, the number of pulse-echo cycles can be quite large (approximately 200-500 cycles per transmit focus) to satisfy the 2-way sampling criterion. As a result, the time required to collect an acoustic data set for each frame is quite large. This gives rise to motion artifacts within the image resulting in diminished temporal resolution.
- **Tissue matched echo processing for differences in tissue type and/or anatomy.** As was mentioned previously, the sound speed in tissue is assumed to be a constant 1540 m/s in beamformer-based systems. This is the number that is used by the ultrasound system for delay and timing. It is known that sound speed varies depending upon the tissue type[3]. Commonly referred to as *aberration*, these sound speed variations can introduce defocusing and clutter in the ultrasound image. To implement an effective aberration compensation algorithm, the ultrasound system must have the capability to automatically identify levels of defocusing and clutter and compensate for them during image formation. This capability does not exist in any of today’s commercial beamformer-based systems.

The limitations of beamformer-based systems are inherent in the technology and any corrective action would undoubtedly involve the abandonment of the beamformer’s basic functionality, which can be described as a “delay and sum” process. The summation process itself represents a loss of potential clinical information since the summed data contains only a fraction of the information available in individual transducer elements[4]. It is this result of the summation that is available to the user. To overcome these limitations a new technology – beyond beamformers – is required.

III. ZONE SONOGRAPHY TECHNOLOGY

ZONE Sonography Technology (ZST)[5,6] is an entirely new approach to ultrasound image acquisition and processing derived from understanding the ideal system characteristics and critically rethinking the underlying physics of sound transmission. Figure 2 shows a simplified block diagram of the ZONE Sonography architecture and the following describes the function of each architectural element:

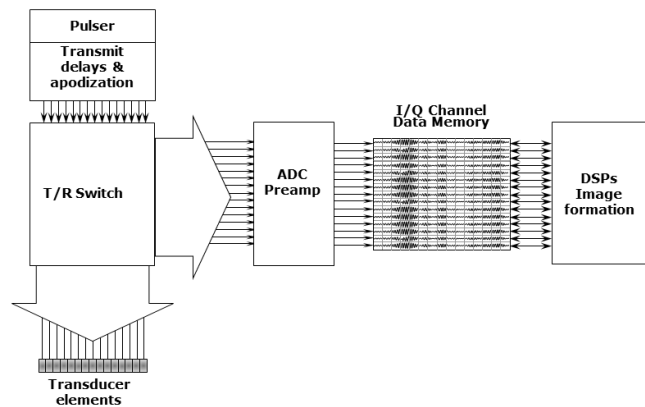

Fig. 2. Simplified block diagram of a ZONE Sonography system. All echoes received by each transducer element are stored in Channel Domain Memory forming a complete acoustic data set for each image frame. This memory is then accessed by Digital Signal Processors (DSP’s) to retrospectively analyze the data and form an image from a complete acoustic data set and not from individual beams. Note that the classic beamformer does not exist in the ZONE Sonography architecture as it has been replaced by software.

- **Pulsar:** Generates waveforms and applies transmit delay and apodization. This causes the transducer to launch a family of non-spatially coincident acoustic waves, ranging from highly focused to plane waves, delivered from multiple origins and/or angles, to sufficiently cover the imaging field. Typically around 50 acoustic waves are transmitted per image in most 2-D applications, a factor of 10 less than required by beamformer-based systems. This enables the system to have excellent temporal resolution.
- **ADC’s and pre-amplification:** Receive echo data is amplified and digitized.
- **Channel Data Memory:** Echoes received by each transducer element are stored in a memory that has as many storage channels as there are transducer elements. The resulting stored data set represents 100% of the echoes acquired during transmit /

receive phases and is used to construct an entire image frame. There is no data lost in summation.

- **Digital Signal Processors (DSP's):** DSP's address the entirety of the echo data set in memory, retrospectively computing echo location by synthesizing a uniform focus and apodization for both transmit and receive at each reconstructed image point. This data set can be analyzed multiple times and in multiple ways to extract new and higher quality image information.

Beamformer-based systems acquire acoustic data serially line-by-line. Focusing and apodization is often dynamic on receive but it is invariably static on transmit resulting in the loss of contrast resolution, detail resolution, and image uniformity. The large number of pulse-echo cycles necessary for artifact free imaging also sacrifices temporal resolution, especially evident in simultaneous imaging modes or the use of multiple transmit foci. The summing process, inherent in all beamformers, eliminates information received by the individual transducer elements. Thus, beamformers use only a small fraction of the actual information contained in the echo data set. ZONE Sonography on the other hand, has the ability to utilize all of the information contained in the returning echo data set and as such can sufficiently cover the imaging field of view in much fewer transmit/receive cycles. While it might be intuitive that simultaneously collecting data from these larger regions would be more efficient, it is understandably less intuitive that fewer acquisitions could result in improved image quality. ZONE Sonography enables this performance advantage by retrospectively analyzing these complete echo datasets to synthesize a continuous transmit focus at *every image point*.

The principal contributions of ZONE Sonography to diagnostic ultrasound imaging are:

- **Dynamic transmit focus and apodization**, resulting in improved image detail resolution, contrast resolution, and image uniformity
- **Fast acoustic interrogation of the tissue space** resulting in improved temporal resolution
- **Storage of acoustic data (Channel Domain Data)** that arrives at each transducer element so that it can be retrospectively analyzed to improve image quality and compensate for patient specific aberrations.

IV. TWO-WAY CONTINUOUS TRANSMIT / RECEIVE FOCUSING

Continuous Transmit/Receive Focusing[7] is a computationally intensive technique which fits into the Zone Sonography system architecture very well. The time saved in acquiring a complete set of image frame echoes (about 10x faster than beamformer-based systems) can now be utilized to improve imaging performance, e.g., data averaging for enhanced Signal to Noise Ratio (SNR) and penetration.

In order to synthesize a continuously focused transmit, a family of non-spatially coincident transmit / receive waves must cover each point to be reconstructed. The phase and amplitude information contained within the set of reconstructed spatially coincident sub-points, reconstructed

from each non-spatially coincident transmit/receive cycle, can then be used to realize a fully focused image point (Fig. 3). Hence, all the information needed to produce a transmit beam focus was available at the time that it was launched – it is encoded within the family of acoustic pulse wavefronts. Capturing all the returning acoustic echoes in the channel domain, scattered by the body for each transmit/receive cycle, for all depths across the transducer array, preserves this encoded information. ZONE Sonography processing extracts this encoded focusing information and corrects, or *refocuses*, the acoustic pulse wavefront for depths away from the designated acoustic focus, thereby creating a transmit focus at each image point, or pixel. This results in improved and uniform resolution, reduced clutter, increased SNR, and allows for a reduced amount of time required to collect a sufficient image data set.

The importance of Continuous Transmit/Receive Focus can be best appreciated through graphics which depict transmit and receive beams generated by a beamformer system, with the transmit beam exhibiting a typical single point of best focus. This can be contrasted with a beam which is continuously focused throughout the depth of the beam. In both cases, the received echoes are focused continuously.

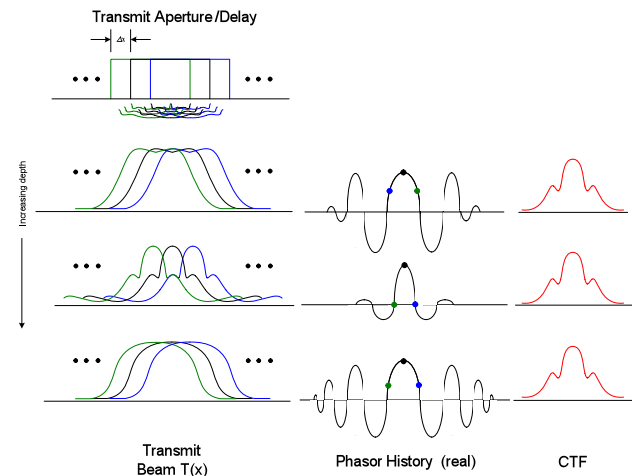

Fig. 3. Pictorial representation of multiple non-spatially coincident transmit wave fronts being used to compute multiple spatially coincident sub-image points for the purpose of using both phase and magnitude to compute a continuous transmit focus (CTF). It can be seen from the phasor history graph that the samples of the phase represent a range varying lateral coded excitation that if sampled properly can be decoded, resulting in a transmit focus.

V. DETAIL AND CONTRAST RESOLUTION: ANALYTIC DATA

The most accurate and analytically rigorous way to measure detail and contrast resolution is through the use of beamplots. The standard way of making beamplots involves a water tank and a needle target which is moved in an arc of constant radius below a transducer which is held in a fixture. The relative sensitivity, or signal strength, is recorded as a function of the angle from the transducer beam pointing direction. The resulting plots show the relative sensitivity, displayed in dB on a logarithmic scale. The horizontal axis is the target angle. Detail resolution is normally measured at -20 dB while contrast resolution is measured in the range of -40 to -60 dB.

Figures (4-8) shows transmit and receive beams, as well as beamplots at various depths, for traditional beamformer and ZONE Sonography acoustic pulse-echo patterns.

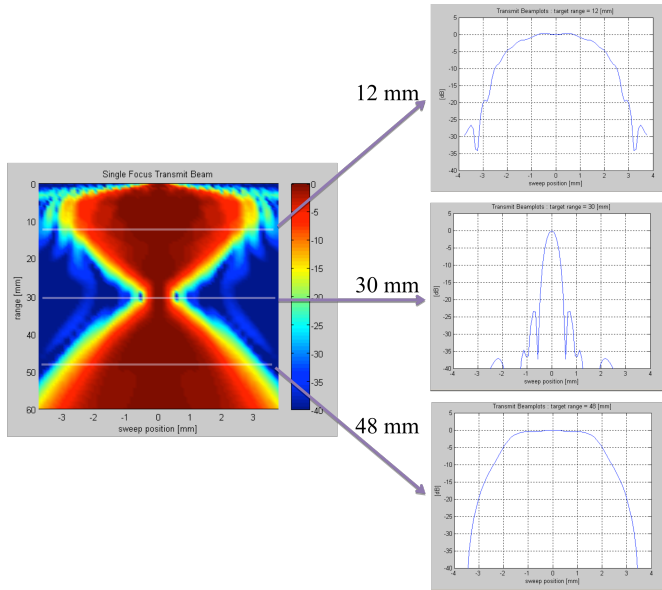

Fig. 4. Traditional beamformer system. Single focus transmit beam. Transducer: L14-5w, 192 elements. Tx focus = 30mm. Tx $F^\# = 2.5$, half circle. Frequency = 10 MHz. Transmit beamplots at 12, 30 and 48 mm are shown on the right

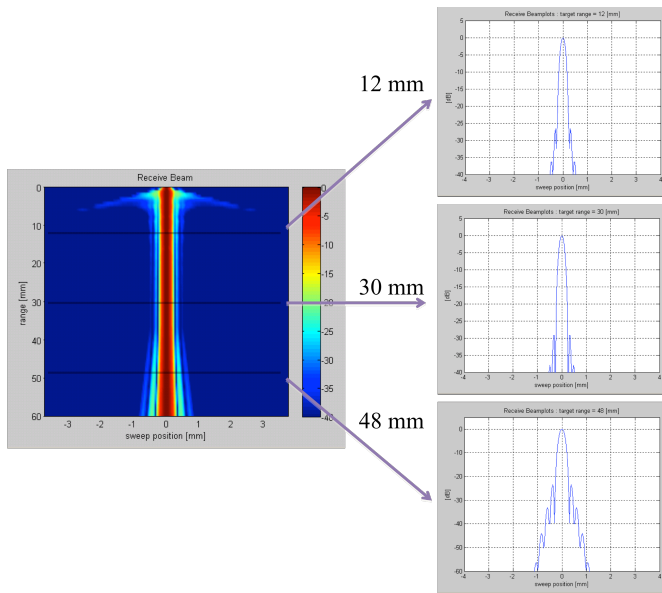

Fig. 5. Traditional beamformer system. Continuously focused receive beam generated by echoes produced by the transmit beam shown in Figure 2. Transducer: L14-5w, 192 elements. Rx $F^\# = 1.0$ Uniform, 128 elements max. Frequency = 10 MHz..

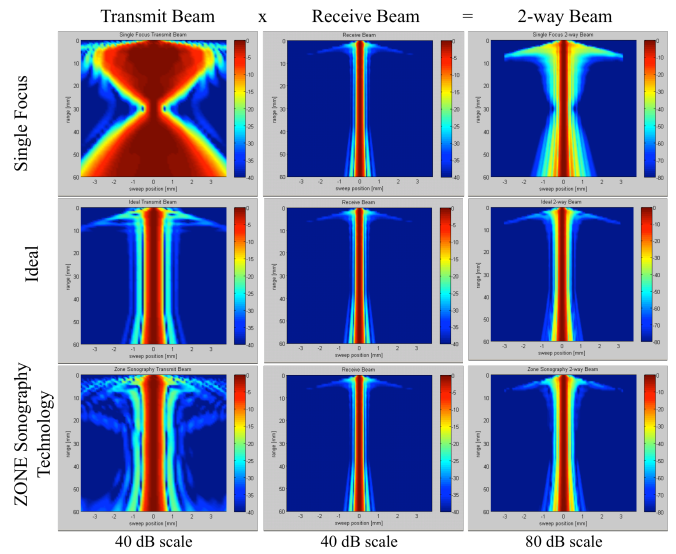

Fig. 6. Beam pattern comparison between a beamformer single-focus system, ideal focus system, and Zone Sonography system. Transducer: L14-5w, 192 elements. Rx $F^\# = 1.0$ Uniform, 128 elements max. Frequency = 10 MHz. Please note that the final beam pattern (product of transmit and receive beams) of the Zone Sonography system approaches the ideal system, both in focus uniformity and clutter.

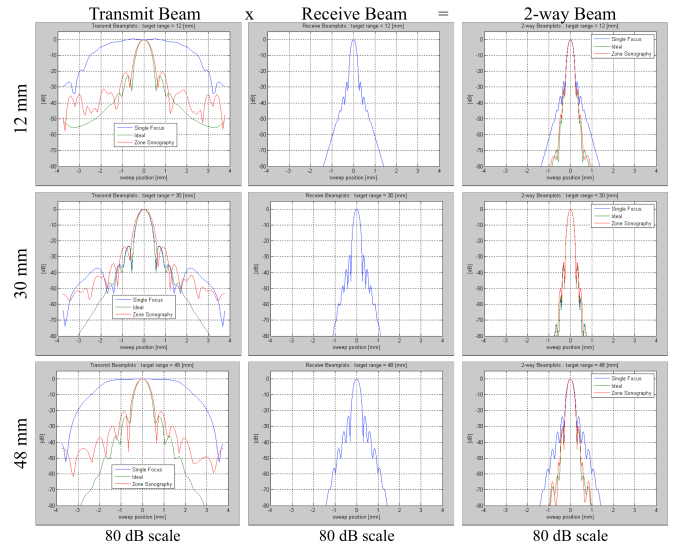

Fig. 7. Beamplot comparisons at 12, 30 and 48 mm for beamformer single-focus system (Blue), Ideal focus system (Green), and ZONE Sonography system (Red). Transducer: L14-5w, 192 elements. Rx $F^\# = 1.0$ Uniform, 128 elements max. Frequency = 10 MHz. Note that detail resolution is the beamwidth at -20dB, while contrast resolution is measured at -60dB

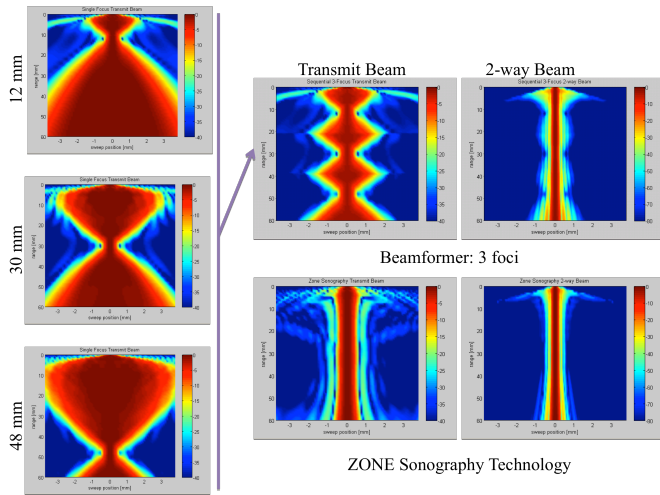

Fig. 8. Comparison of 3-zone sequential focus which reduces acquisition time and frame rate by a factor of 3, and ZONE Sonography continuous transmit/receive focus. Transducer: L14-5w, 192 elements. Rx $F^{\#} = 1.0$ Uniform, 128 elements max. Frequency = 10 MHz. Three-zone sequential focus represents a significant improvement in image uniformity, but reduced frame rate detracts from this approach

Both transmit and receive beams contribute to the final image sample. Recall that the image is composed of a large number of these samples (or beams), often as high as 300. The final two-way beam is actually the product of the transmit beam and receive beam as shown in Figures 6 and 7. This process, repeated for each beam, is one of the functions of the beamformer electronics.

VI. PHANTOM IMAGES

A high dynamic range phantom can be used to demonstrate the transmit wavefront characteristics with the continuous transmit focus turned OFF and then turned ON (Fig. 9). Both images were formed from the same data set stored in Channel Domain Memory, thus minimizing potential variables which may bias the comparison. These images were representative of the images collected during the imaging session.

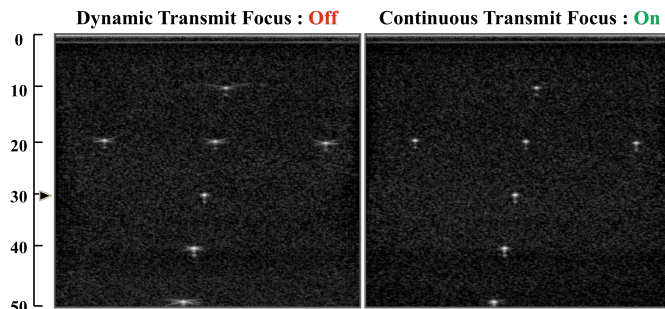

Fig. 9. The continuous transmit focus turned OFF image has the single transmit focus placed at 30 mm. Note the clutter around the pins as one moves away from the 30 mm point of best focus. Turning ON the continuous transmit focus minimizes clutter at all depths.

VII. CLINICAL IMAGES

Clinical image comparisons were made using the same data set stored in Channel Domain Memory and formed with transmit focus turned OFF and then ON. A L14-5w imaging transducer operating at 12 MHz frequency was used to collect Fig. 10 and 11 echo data. Fig. 12 shows a similar comparison collected on the C6-2 transducer at a 6MHz compounded harmonic frequency.

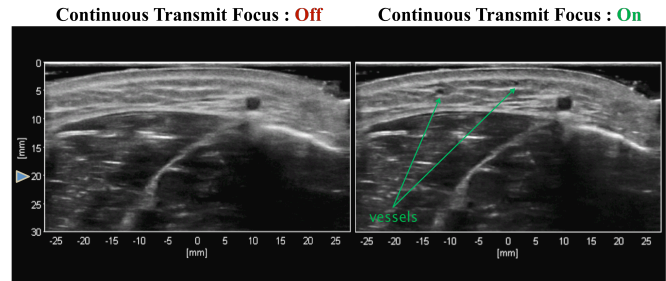

Fig. 10. A calf image with fixed transmit focus at 20 mm. Using the same data set, a continuous transmit focus image was formed illustrating the improved detail and contrast resolution.

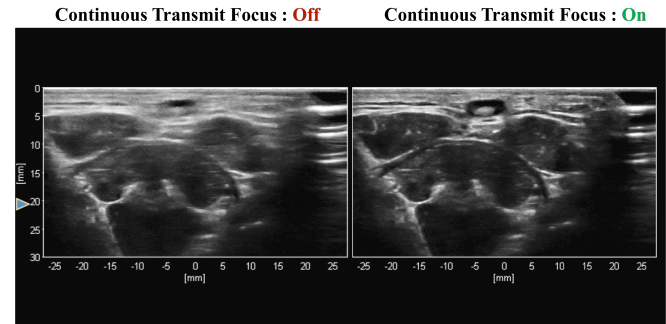

Fig. 11. A chin image with transmit focus turned OFF and fixed focus set at 20 mm demonstrates loss of detail and contrast resolution when compared to an image with continuous transmit focus turned ON

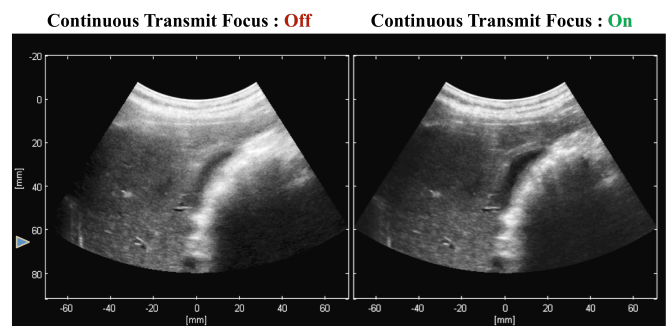

Fig. 12. Gall bladder and liver image obtained using a C6-2 transducer operating in compound harmonic mode at 6 MHz with a fixed focus set at 65 mm. Note the reduction of noise and clutter now that continuous transmit focus is turned ON, which had previously obscured detail of both the gall bladder and liver

VIII. IMAGE QUALITY PARAMETERS

Detail resolution and contrast resolution are two of the most common parameters used to describe image quality. Both parameters can be directly obtained from beamplots where detail resolution is measured at -20 dB, and contrast resolution

is measured at -60 dB. A Figure of Merit (FOM) has been developed in order to be able to arrive at a way to compare results from a single-focus beamformer system to the ZONE Sonography Two-Way Continuous Transmit/Receive Focus. The measured parameters have been normalized to the ideal system and in all cases, the transmit beam was generated with a transmit $F^{\#} = 2.5$ and receive $F^{\#} = 1.0$.

$$FOM(normalized) = \frac{1}{\alpha \frac{\sigma_D}{\sigma_D(ideal)} + \beta \frac{\sigma_C}{\sigma_C(ideal)}}$$

Where:

$$\begin{aligned} \sigma_D &= \text{mean detail resolution (mm)} \\ \sigma_C &= \text{mean contrast resolution (mm)} \\ \alpha, \beta &= \text{weighting factors, where } \alpha + \beta = 1 \end{aligned}$$

Data obtained from beamplots is summarized in Table 1, while the depth dependence of these parameters is shown in Fig. 13.

Table 1

Case	Detail Resolution (mm)	Contrast Resolution (mm)	Figure of Merit (normalized)
Ideal	0.442	1.143	1.0
ZONE Sonography	0.447	1.238	0.95
Beamformer 1 focus	0.461	2.108	0.69
Beamformer 3 foci*	0.455	1.614	0.82

*Frame acquisition time increased by 3X

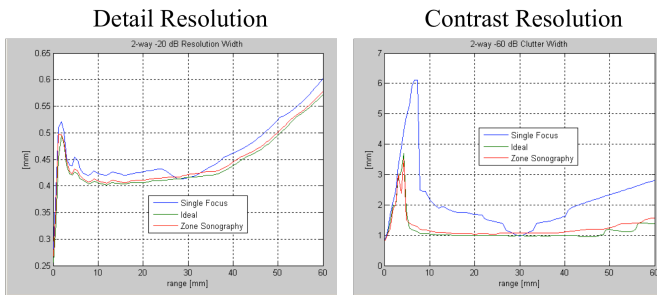

Fig. 13. Graphs of the detail resolution (-20dB) and contrast resolution (-60dB) versus depth of the beamformer single-focus system (Blue), Ideal focus system (Green), and ZONE Sonography Technology system (Red) as measured from Fig 6. The Tx focus was placed at 30 mm. The graph shows that the ZONE Sonography closely approximates that of the ideal focus system at all depths.

Given that the processing used to generate the Tx focus in ZST is a coherent process, there is also the added benefit that the overall SNR of the system away from the Tx focus is also enhanced (Fig. 14).

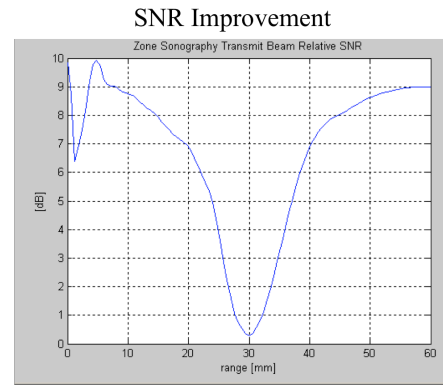

Fig. 14. Graph of the range dependent SNR enhancement calculated from the coefficients used to produce a CTF of the ZST system compared to a normalized single-focus beamformer system with a Tx focus placed at 30 mm. It can be seen that there is little SNR enhancement at the Tx focus, as there is no additional focusing possible, but away from the focus there can be as much as 10 dB SNR gain.

IX. CONCLUSION AND RELEVANCE

- Two-Way Continuous Transmit/Receive Focusing improves the detail and contrast resolution Figure of Merit by ~38%
- Two-Way Continuous Transmit/Receive Focusing shows the most significant improvement in contrast resolution
- Sequential transmit foci improve detail and contrast resolution, but at a considerable penalty in frame acquisition time
- ZONE Sonography Two-Way Continuous Transmit/Receive Focusing images exhibit excellent image uniformity throughout the FOV (excluding aperture effects)
- Operator interaction with system is simplified through elimination of “Focal Zone” control
- Two-Way Continuous Transmit/Receive Focusing is effective in all applications and on all transducers

REFERENCES

- [1] K. E. Thomenius, “Evolution of Ultrasound Beamformers,” Proc 1996 IEEE Ultrasonics Symp, vol. 2, pp 1615-1622.
- [2] S. Maslak, “Computed Sonography,” Ultrasound Annual 1985, Edited by Sanders, R.C. and Hill, M.C., Raven Press, 1985, pp. 1-16.
- [3] T. D. Mast, “Empirical Relationship Between Acoustic Parameters in Human Soft Tissue,” ARLO vol.1, issue2, Nov. 2000, pp 37-42.
- [4] C. M. Fabian, K. N. Ballu, J. A. Hossack, T. N. Blalock, and W. R. Walker, “Development of a Parallel Acquisition System for Ultrasound Research,” Proc 2001 SPIE, vol. 5325, pp 54-62.
- [5] D. Napolitano, C. H. Chou, G. W. McLaughlin, D. DeBusschere, L. Y. L. Mo, and T. L. Ji, “Zone-Based B-Mode Imaging,” Proc 2003 IEEE Ultrasonics Symp, vol. 1, pp 25-28.
- [6] G. W. McLaughlin, T. L. Ji, “Broad-Beam Imaging,” US Patent: 6,685,645, Issued: Feb. 2004.
- [7] D. J. Napolitano, B. D. DeBusschere, G. W. McLaughlin, L. Y. L. Mo, C. H. Chou, T. L. Ji, R. W. Steins, “Continuous Transmit Focusing Method and Apparatus for Ultrasound Imaging System,” US Patent: 8,002,705, Issued: Aug. 2011.